

# Measurement of Wireless Power Transfer to Multiple Loads by a Vector Network Analyser

Kazuya Yamaguchi<sup>#1</sup>, Ikuo Awai<sup>#2</sup>, Toshio Ishizaki<sup>\*3</sup>

<sup>#</sup> Ryutech Corporation

1-5 Yokotani, Seta-oecho, Otsu 520-2194 Japan

<sup>1</sup>lefttokei@yahoo.co.jp

<sup>2</sup>awai@ryutech.com

<sup>\*</sup> Dept. of Electronics & Informatics, Ryukoku University

1-5 Yokotani, Seta-oecho, Otsu 520-2194 Japan

<sup>3</sup>ishizaki@rins.ryukoku.ac.jp

**Abstract**—A new scheme to use a constant current RF source (CCS) is proposed for the coupled-resonator wireless power transfer system. Considering it is hard to obtain a general-use CCS, an alternative use of common 50Ω signal source followed by Scattering to Impedance parameter transform is recommended with the theory of the transform, verification of the theory and some practical examples.

## I. INTRODUCTION

A vector network analyser (VNA) is a standard measurement instrument for devices, circuits and systems in the high frequency communication engineering, due to its versatility, high precision and wide dynamic range. It is well fitted to the 50 ohm input/output impedance of the RF signal source as well as most communication circuits. The emerging wireless power transfer technology, however, requires a highly efficient power source with 90 % or so, which is realized by a switching inverter such as class D or E amplifiers. Considering a 50 ohm signal source is of quite low efficiency, say 20 %, it is evidently not applicable to the wireless power transfer system, and moreover, a VNA with the input/output impedance 50 Ω may also be excluded from the measurement of the WPT system.

Then, what should be done for that is to adopt an oscilloscope or power analyser with voltage/ current probes, instead of VNAs. Though these instruments are standard for the power electronics engineers indeed, they are not so for the communication engineers. Those engineers are not accustomed to the time domain measurement. Besides that, the resonators which constitute the main part of power transfer system are accurately and conveniently measured by a VNA. Thus, it would be important to keep the VNAs effective also for the wireless power transfer (WPT) system measurement.

The background to use 50Ω instrument for non-50Ω systems stems from the invariance of the impedance parameters ( $Z$  parameters) of any electric circuits irrespective of the external circuits. The first step of the measurement starts from the scattering parameters ( $S$  Parameters) of the device under test (DUT) under 50Ω condition. Since  $S$  parameters are transformed into  $Z$  parameters easily, the latter is utilized to calculate the circuit response of arbitrary external circuit impedances including the constant voltage source

(CVS) with 0 Ω output impedance or a constant current source (CCV) with infinity Ω output impedance.

There has been reported few theories for wireless delivery of power to multiple loads so far [1]. Though Ref. 1 tries to analyse it theoretically, they seem to develop their theory under the premise of 50Ω power source. According to the experience of connecting multiple home appliances to the outlets in the home, we may consider that a constant voltage source will be the best solution for that. But we have to consider the role of mutual inductance between the primary and secondary resonators of the “magnetic resonance” WPT system [2]. A new theory will give the solution in the following sections.

## II. SZ TRANSFORM

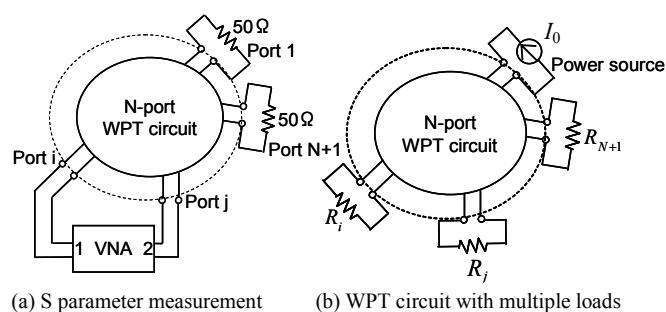

Fig. 1 Procedure for transform of measured  $S$  parameters into  $Z$  parameters for a WPT system

The transform from  $S$  to  $Z$  parameters is carried out according to the following relation

$$[\hat{Z}] = \{[E] - [S]\}^{-1} \{[E] + [S]\} \quad (1)$$

, where  $[\hat{Z}]$  is the normalized  $Z$  matrix,  $[S]$  is the  $S$  matrix and  $[E]$  gives the unit matrix. The corresponding circuits are drawn in Fig. 1, which describes (a) the circuit connection for  $S$  parameter measurement and (b) that for calculation of the system response. It shows the case that the constant RF

current source (CCS) delivers the power. First of all, a vector network analyser measures all the  $S$  parameters, connecting to the terminals alternately. Then, they are substituted into Eq. (1) to obtain the normalized  $Z$  parameters, which are invariant to the external circuit. The general relation between the voltage and current at each port is

$$\begin{bmatrix} V_1 \\ \vdots \\ V_{N+1} \end{bmatrix} = [\sqrt{Z_0}] [\hat{Z}] [\sqrt{Z_0}] \begin{bmatrix} I_1 \\ \vdots \\ I_{N+1} \end{bmatrix} \quad (2)$$

, where  $[\sqrt{Z_0}]$  is a diagonal matrix with the element of square root of terminal characteristic impedance ( $n=1,2, \dots, N+1$ ). Considering that the input/output impedance of a VNA is  $50\Omega$ , Eq. (2) reduces to

$$\begin{bmatrix} V_1 \\ \vdots \\ V_{N+1} \end{bmatrix} = 50[\hat{Z}] \begin{bmatrix} I_1 \\ \vdots \\ I_{N+1} \end{bmatrix} \quad (3)$$

At each terminal except #1, the relation

$$V_n = R_n I_n \quad (n = 2, \dots, N) \quad (4)$$

holds and at Terminal #1,

$$V_1 = E, \quad \text{or} \quad I_1 = I_0 \quad (5)$$

for the constant voltage source (CVS) or constant current source (CCS), respectively.

### III. VALIDITY OF SZ TRANSFORM

A direct confirmation of the validity of SZ (Scattering and Impedance parameters) transform is carried out for the basic one-source and one-load system shown in Fig. 2. The equivalent circuit is in Fig. 2(b), where the circuit parameters are measured to be

Spiral coil diameter 20cm, 9 turns, pitch 1cm,  
 $L_1=L_2=7.81\mu\text{H}$ ,  $R_1=R_2=0.589\Omega$ ,  $M=1.22\mu\text{H}$  (coil distance:  
 7cm),  $C_1=C_2=361\text{pF}$ ,  $R_f=25\Omega$ ,  $f_0=3\text{MHz}$

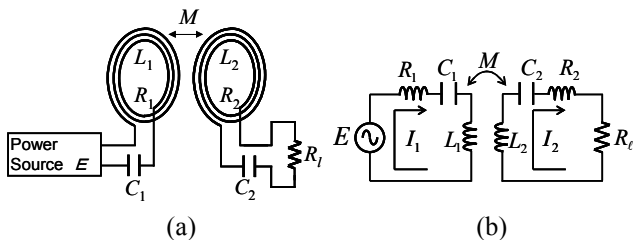

Fig. 2 WPT circuit to confirm validity of SZ transform. (a) Rough sketch of system (b) Equivalent circuit

The  $S$  parameters are measured at the input port of the primary resonator and at the output port of the secondary resonator with a vector network analyser Bode 100

manufactured by Omicron Lab. The calculated system response on the basis of the measured  $S$  parameters using Eqs. (1)- (5) is shown in Fig. 3. The circuit-simulation result of the equivalent circuit in Fig. 2(b) with the parameters shown above it is also depicted in Fig. 3. An excellent coincidence between the measured and calculated results is observed, confirming the validity of the transform theory and the equivalent circuit.

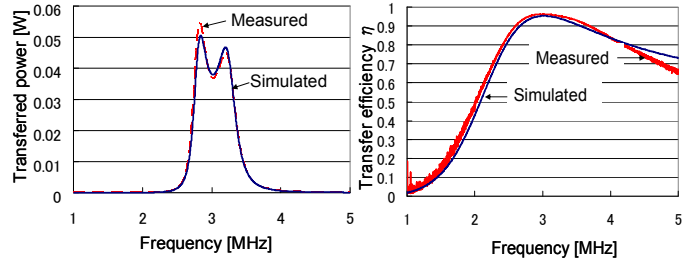

Fig. 3 Frequency response transformed from  $S$  parameters measured by vector network analyser. (a) Transferred power (b) Transfer efficiency

As another confirmation, we will measure the circuit using an oscilloscope DPO3014 by Tektronix with voltage and current probes as described in Fig. 4. An example of measured voltage and current at the primary and secondary coils are shown in Fig. 5, whereas their numerical values are depicted in TABLE I.

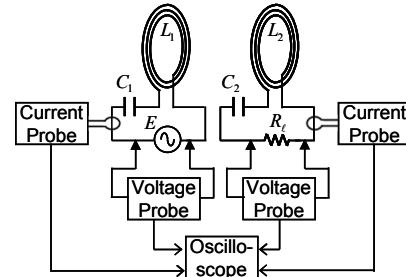

Fig. 4 Measurement setup by oscilloscope

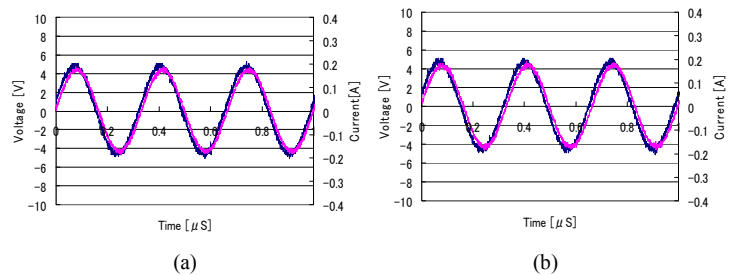

Fig. 5 Measured voltage/current waveforms at input and output ports. (a) Input port (b) Output port

TABLE I MEASURED INPUT/ OUTPUT VOLTAGE, CURRENT AND POWER

Resonator	Voltage[V]	Current[A]	Power[W]
Primary	3.46	0.126	0.436 ( $P_1$ )
Secondary	3.32	0.123	0.409 ( $P_2$ )

Dividing the output power by the input power in Table 1, we obtain 0.94, which compares well with the measured result 0.96 through S parameters. They agree quite well, confirming the validity of the SZ transform.

#### IV. COMPARISON OF CONSTANT VOLTAGE/CURRENT SOURCES

Though both voltage and current sources are applicable to the one-load WPT system, there is a question whether it is true for the multiple-load system, too. In Fig. 6, a WPT circuit delivering power to two loads is depicted that can alternate the power source from a CCS to CVS. The two identical secondary resonators are located symmetrically at the both sides of the primary resonator, making the system construction easier. The equivalent circuit is drawn in Fig. 6(b), whose circuit parameters are measured by a VNA,

$$\begin{aligned} f_0 &= 3.09 \text{ MHz}, L_0 = L_1 = L_2 = 7.83 \mu\text{H}, C_0 = C_1 = C_2 = 339 \text{ pF} \\ M_{01} &= 1.98 \mu\text{H}, M_{02} = 2.01 \mu\text{H}, M_{12} = 0.73 \mu\text{H} \\ R_{l1} = R_{l2} &= 39 \Omega, R_0 = R_1 = R_2 = 0.595 \Omega, I_0 = 1 \text{ A or } E = 1 \text{ V} \end{aligned}$$

These values are used for the circuit simulation and have given a good coincidence with the measured response, but it will not be shown for simplicity of the figures.

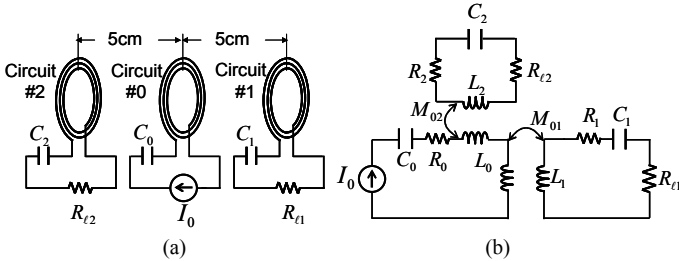

Fig. 6 Symmetrical WPT circuit that transfers power to 2 loads. (a) Rough sketch of circuit configuration (b) Equivalent circuit

Since the measured S parameters are transformed to Z parameters by use of Eq. (1), the equations for the input power  $P_0$  and output power  $P_1, P_2$  derived by Eq. (2) through (5)

$$P_0 = \text{Re}[V_0^* I_0] \quad (6)$$

$$P_1 = R_{l1} |I_1|^2, \quad P_2 = R_{l2} |I_2|^2 \quad (7)$$

will give the calculated values. The frequency characteristic of the output power and the transfer efficiency

$$\eta = \frac{P_1 + P_2}{P_0} \quad (8)$$

for the CVS and CCS are depicted in Fig. 7 and Fig. 8, respectively. Though the transferred power is very different for the number of loads depending on CVS or CCS, the efficiency is almost the same for two kinds of source.

Considering the constant voltage source (CVS) delivers only less than half power compared with the case of single load while the constant current source (CCS) gives almost twice of that, we may conclude the CCS is more adequate for

the power transfer to multiple loads than the CVS. It is because the constant voltage of the primary coil is divided into the electromotive force of each secondary coil, and it decrease with the number of secondary resonators.

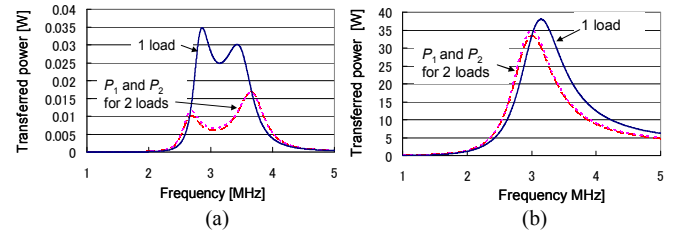

Fig. 7 Comparison of transferred power to single or double loads. (a) Constant voltage source (b) Constant current source

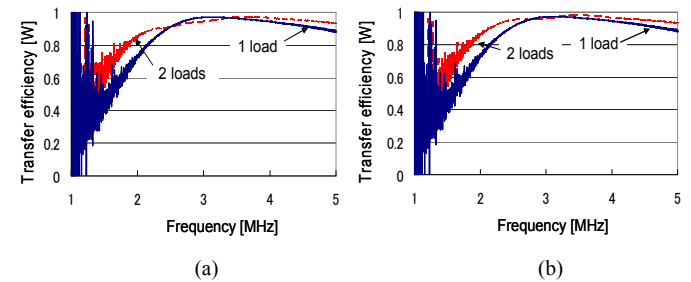

Fig. 8 Comparison of total transfer efficiency for single or double loads. (a) Constant voltage source (b) Constant current source

#### V. SOME EXAMPLES OF CCS EXCITATION

Now that we have known the constant current source (CCS) is a good solution for multiple loads, we will focus on that source hereafter. The current of the CCS is assumed as 1A following the former example.

##### A. The case the secondary resonators are sufficiently smaller than the primary

Figure 9 describes the system structure, where the equivalent circuit is just the same as Fig. 6(b). The present structure is quite common for the charging system of mobile instruments such as smart phones or i-phones. It should be noted that capacitors are connected to each coil to resonate them with 3MHz. The circuit elements have the values indicated in TABLE II.

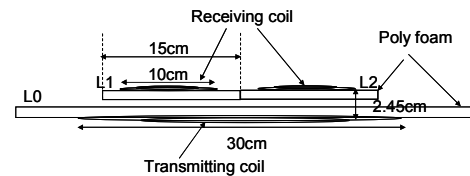

Fig. 9 Rough sketch of WPT circuit configuration that transfers power to 2 loads via small coils.

The transferred power and the transfer efficiency for is measured and calculated as shown in Fig. 10. The SZ transform-based measurement and the circuit simulation result

agree quite well, indicating the feasibility of the proposed method. It should also be noted that the transferred power to each load is just the same as that for the case of single load, resulting in the twice for the total power.

TABLE III VALUES OF CIRCUIT PARAMETERS FOR FIG 9

$f_0$ [MHz]	$L_0$ [ $\mu$ H]	$L_1$ [ $\mu$ H]	$L_2$ [ $\mu$ H]	$C_0$ [pF]	$C_1$ [pF]	$C_2$ [pF]
3.005	5.54	4.17	4.19	506	673	670
Coupling coeff: $k_{01}$	$k_{02}$	$k_{12}$	Unloaded Q: $Q_{u0}$	$Q_{u1}$	$Q_{u2}$	
0.0945	0.0945	0	164	174	175	

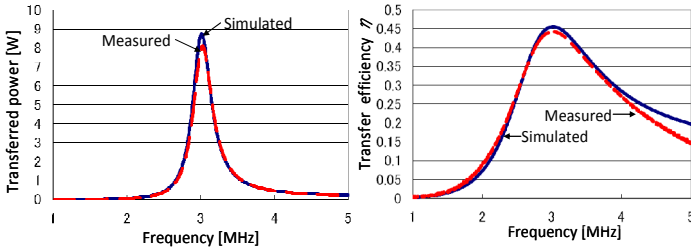

Fig. 10 Frequency response of circuit in Fig. 9 measured by vector network analyser. (a) Transferred power (b) Transfer efficiency

### B. The case the load impedances are different each other

Using the same configuration as Fig. 9, we have prepared two different secondary circuits. It is the case when they want to charge two different types of wireless gadget at the same time. The load impedance ( $R_{11}$  and  $R_{12}$ ) are assumed different each other, and hence, the inductance of the secondary resonator ( $L_1$  and  $L_2$ ) are set different according to each matching condition [4],

$$k_{en} = \frac{R_{in}}{\omega_0 L_n} = k_n \sqrt{\frac{Q_0}{Q_n}} \quad (n = 1, 2) \quad (9)$$

, where  $Q_0$  is the unloaded Q of the primary resonator. The quantity  $k_{en}$  is the external k,  $R_{in}$  is the load resistance,  $L_i$  is the self inductance,  $k_n$  is the coupling coefficient between the primary and each secondary resonator and  $Q_n$  is their unloaded Q. The fabricated system is shown in Fig. 11

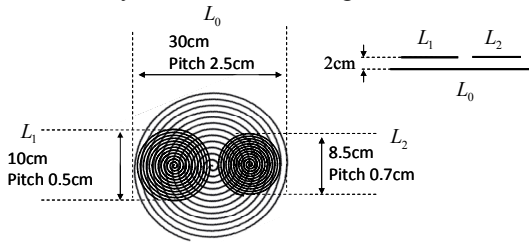

$f_0$ [MHz]	$L_0$ [ $\mu$ H]	$L_1$ [ $\mu$ H]	$L_2$ [ $\mu$ H]	$Q_0$	$Q_1$	$Q_2$
2.985	5.3	4.0	1.8	166	176	114
$k_1$	$k_2$	$k_{12}$	$R_{11}$	$R_{12}$		
0.096	0.072	Almost 0	7.22	2.43		

Fig. 11 Dimensions and circuit element values for fabricated system

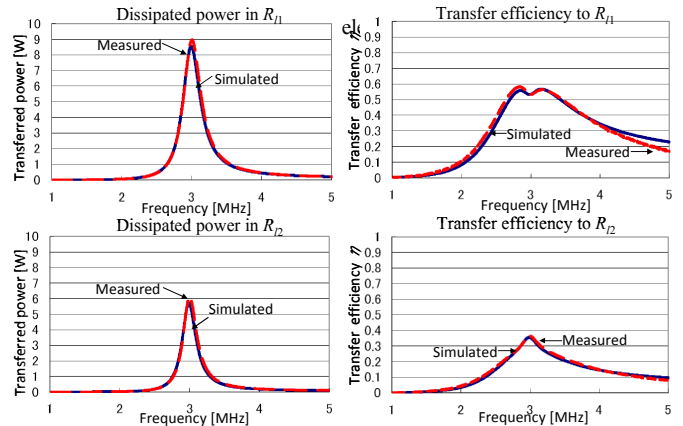

Fig. 12 Transferred power and efficiency for each load of system in Fig. 11.

The measured and calculated results are shown in Fig. 12 again expressing good coincidence. We find the total efficiency is above 80%. The difference of the transfer efficiency for each load comes from the difference in  $k_n Q_n$  product. This result shows that each load can be matched to the primary resonator independent of the other loads.

## VI. CONCLUSION

We have studied the  $S$  parameter-  $Z$  parameter transform for measurement of the WPT system with a constant voltage or current power source [2] [3], and have shown its validity and feasibility. In the present article, at first, we added new evidence that the transform is assured by the time domain measurement with an oscilloscope.

Based on the certified theory, secondly, we have proposed to use a constant current source instead of a constant voltage source to feed multiple loads at the same time, by verifying that the former delivers power additively according to the number of loads, while the latter does not. It is an unexpected result, considering the commercial utility power system. The matching for each load can be carried out independently.

Lastly, we have shown some useful examples to feed multiple loads. They are encountered quite often in the daily life. More examples will be shown at the presentation.

## REFERENCES

- [1] D. Ahn and S. Hong, "Effect of Coupling between Multiple Transmitters or Multiple Receivers on Wireless Power Transfer," *IEEE Trans., Ind. Electron.* vol. 60, 2013, to be published.
- [2] T. Ishida, K. Yamaguchi, T. Ishizaki and I. Awai, "Measurement of WPT Circuits by VNA and Its Data Transformation into  $0\Omega$  System," in *IEEE IMWS-IWPT Digest*, May 2012, pp. 231-234.
- [3] I. Awai, K. Yamaguchi, T. Ishida and T. Ishizaki, "Design of Resonator-coupled WPT System with Multiple Load Based on Measurement with a VNA Instead of an Oscilloscope", in *Proc. APMC 2012*, Dec. 2012, to be presented.
- [4] I. Awai and T. Ishizaki, "Transferred Power and Its Efficiency in a Coupled-resonator WPT System", in *IEEE IMWS-IWPT Digest*, May 2012, pp. 105-108.