

An Efficient Algorithm for Transmitting Power Maximization of Phased Arrays Including Amplitude Degradation

Tomohiko Mitani^{#1}, Shunji Tanaka^{*2}, Yoshio Ebihara^{*3}

[#] *Research Institute for Sustainable Humanosphere, Kyoto University
Gokasho, Uji, Kyoto 611-0011, Japan*

¹ mitani@rish.kyoto-u.ac.jp

^{*} *Department of Electrical Engineering, Kyoto University
Kyotodaigaku-Katsura, Nishikyo-ku, Kyoto 615-8510, Japan*

² tanaka@kuee.kyoto-u.ac.jp

³ ebihara@kuee.kyoto-u.ac.jp

Abstract— An efficient algorithm was developed for transmitting power maximization of phased arrays including amplitude degradation. A large-scale phased array will be adopted as transmitting antenna of a solar power satellite project. The amplitude of each antenna element will be degraded at every phase shift due to long-term operation and failure of antenna units. This array problem is formulated as a discrete optimization problem, and decomposed into element-wise subproblems by utilizing the real rotation theorem. Then a polynomial-time algorithm to solve the problem numerically was constructed.

I. INTRODUCTION

A solar power satellite (SPS) [1, 2] is a future power plant which generates electricity in space by photovoltaic cells, and transmits power from space to the Earth via microwave or laser. The microwave-based SPS is required to transmit the microwave power to the desired direction precisely and efficiently. Hence a large-scale phased array will be adopted as transmitting antenna, and a digital phase shifter will be mounted on each antenna element for beam control.

The objective of the present study is to maximize the transmitting power of phased arrays including amplitude degradation. In the conventional phased array [e.g. 3], the amplitude of each antenna element is assumed to be unity or constant regardless of phase shifts. However, in a real situation, the amplitude of each antenna element will be degraded at every phase shift due to long-term operation and failure of antenna units. Fakharzadeh et al. [4] proposed a beamforming method under the condition that an analog phase shifter provides nonlinear transmission loss depending on its phase shift. The authors previously developed an algorithm for transmitting power maximization of phased arrays including lossy digital phase shifters and confirmed its effectiveness by experimental demonstration [5].

In the present paper, an efficient polynomial-time algorithm of phased arrays including amplitude attenuation, which is known precisely beforehand, is proposed. We formulated the phased array problem as a discrete optimization problem and decomposed it into element-wise subproblems by utilizing the

real rotation theorem. Then we conducted numerical simulations to verify the effectiveness of our developed algorithm.

II. DESCRIPTION OF PHASED ARRAY PROBLEM

Consider a one-dimensional phased array antenna composed of N isotropic antenna elements with d spacing, as shown in Fig.1. Each antenna element has a digital phase shifter given by a set of \mathcal{W} and a phase shift $w \in \mathcal{W}$. Denoting the phase shift of the p -element by w_p and the main beam direction by θ , the radiated electric field of the array can be expressed by

$$E(\mathbf{w}; \theta) = \sum_{p=1}^N a(w_p) \exp\{j(w_p + s_p(\theta))\}.$$

Here $a(w_p)$ is the amplitude of antenna element at the phase shift w_p , and $s_p(\theta)$ is the space phase factor of the p -element defined by

$$s_p(\theta) = \frac{2\pi d}{\lambda} (p-1) \sin \theta$$

where λ is the wavelength.

In this paper, the radiated magnetic field, mutual coupling effects and cross-polarization effects are not considered in order to focus on the effectiveness of our developed algorithm. Then the transmitting power maximization problem, in other words, the array gain maximization problem can be expressed by the following discrete optimization problem (P):

$$A = \max_{\mathbf{w} \in \mathcal{W}^N} |E(\mathbf{w}; \theta)|,$$

since the array gain is obtained from $|E(\mathbf{w}; \theta)|^2$.

In the conventional phased array, the amplitude $a(w)$ is assumed to be unity or constant regardless of phase shifts in the conventional phased array. Then (P) can be solved by determining the phase shift of each antenna to cancel the

space phase factor: $w_p = -s_p(\theta)$. In the case of digital phase shifter, w_p is round off to the nearest phase shift achievable by the mounted digital phase shifter.

In a real situation, however, the amplitude of each antenna element will be degraded at every phase shift, i.e. $a(w) \leq 1$. In this case, the solution of the problem (P) is not always given by $w_p = -s_p(\theta)$. As a simple and unconsidered solution method, (P) can be solved exactly by enumerating all the possible decision variables w . However this enumerative approach is intractable for large-scale phased arrays like SPS, because it takes $O(|W|^n)$ time where $|W|$ is the cardinality of W . In other words, the computational complexity of this enumerative approach depends exponentially on the number of antenna elements.

We therefore propose a polynomial-time algorithm that solves the problem (P) of the phased array including the amplitude attenuation in this paper. Our developed polynomial-time algorithm can solve the problem (P) numerically by decomposing (P) into element-wise subproblems.

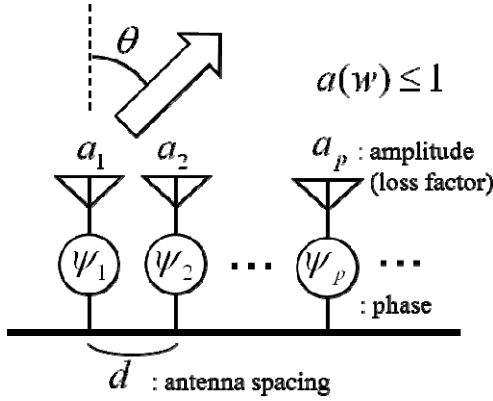

Fig. 1. Alignment of a one-dimensional phased array antenna

III. POLYNOMIAL-TIME ALGORITHM BASED ON PROBLEM DECOMPOSITION

The problem (P) can be decomposed into subproblems with the following real rotation theorem:

$$|z| = \max_{0 \leq \xi < 2\pi} \operatorname{Re}\{z \cdot \exp(j\xi)\},$$

where z is an arbitrary complex number. By using this theorem, the optimal objective value A of (P) can be eventually rewritten as follows:

$$A = \max_{0 \leq \xi < 2\pi} \sum_{p=1}^n \max_{w_p \in W} a(w_p) \cos(w_p + s_p(\theta) + \xi).$$

The equation above implies that (P) is decomposed into subproblems corresponding to individual antenna elements. Introducing the following subproblems (P_p):

$$R_p(\xi) = \max_{w_p \in W} a(w_p) \cos(w_p + s_p(\theta) + \xi),$$

(P) can be converted to the following problem (PD):

$$A = \max_{0 \leq \xi < 2\pi} R(\xi) = \max_{0 \leq \xi < 2\pi} \sum_{p=1}^n R_p(\xi).$$

Here we introduce the problem (S):

$$R_S(\xi) = \max_{w \in W} a(w) \cos(w + \xi),$$

and denote an optimal solution of (S) by $w_S^*(\xi)$. Obviously $w_S^*(\xi)$ and $R_S(\xi)$ have the periodicity of 2π . Furthermore, an optimal solution of $w_p^*(\xi)$ and the optimal objective value

$R_p(\xi)$ of (P_p) can be written by

$$w_p^*(\xi) = w_S^*(\xi + s_p), \quad R_p(\xi) = R_S(\xi + s_p).$$

Finally, the problem (PD) can be expressed as follows:

$$A = \max_{0 \leq \xi < 2\pi} R(\xi) = \max_{0 \leq \xi < 2\pi} \sum_{p=1}^n R_S(\xi + s_p).$$

To solve (PD), it is necessary to find

$$\xi^* = \arg \max_{\xi} R(\xi).$$

Note that $R(\xi)$ is a piecewise smooth function and it is given by the sum of cosine functions in each smooth intervals. Moreover, the number of such intervals is bounded by a polynomial of the number of antenna elements n and the number of possible phase shifts $|W|$. Therefore the solution of (PD) can be obtained in a polynomial time. In other words, the computational complexity of our developed algorithm depends on the number of arrays in a polynomial time. Concretely, the overall computational complexity of our developed algorithm is $O(n |W|^2 \log(n |W|^2))$.

IV. NUMERICAL SIMULATIONS

Numerical simulations of phased arrays were conducted to verify the effectiveness of our developed algorithm. The antenna alignment was expanded to two dimensions in the numerical simulations, and square arrays were considered. Each antenna element includes a m -bit cascaded phase shifter, which consists of 1-bit phase shifter by m cascades and can shift the phase discretely in $180/2^{m-1}$ -degree increment from 0 to 360 degrees (m : natural number). We assumed that the amplitude degradation of α ($0 < \alpha \leq 1$) takes place when a 1-bit phase shifter is switched on to shift the phase. Table I shows an example of phase shift and amplitude attenuation in the case of 2-bit cascaded phase shifter. The number of antennas was changed from 100 x 100 to 1000 x 1000, and m was from 1 to 4. In the simulations, the main beam was steered toward the direction (θ, ϕ) where θ and ϕ indicates polar angle and azimuth angle in the spherical coordinate system. The developed algorithm was coded in C Language and run on a desktop computer with an Intel® Core™2 Duo E6850 CPU (3.0 GHz).

TABLE I
PHASE SHIFT AND AMPLITUDE DEGRADATION OF A 2-BIT CASCADED PHASE SHIFTER IN NUMERICAL SIMULATIONS

1-bit phase shifter		Phase shift	Amplitude degradation
90°	180°		
off	off	0°	1
on	off	90°	α
off	on	180°	α
on	on	270°	α^2

A. Computational Time

We measured the computational time to verify the effectiveness of our developed algorithm. The main beam direction was fixed to $(\theta, \phi) = (10^\circ, 30^\circ)$. In the case of solving the decomposed problem (PD) by our developed algorithm, the measured computational time was less than 10 seconds even when the simulation was conducted under the largest number (the number of antennas: 1000 x 1000, 4-bit phase shifter). On the other hand, trying to solve the original problem (P) by enumerative approach, the measured computational time became more than 500 seconds even in the case of 3 x 3 antenna size and 4-bit phase shifter. This computational time comparison verifies the effectiveness of our developed algorithm.

B. Antenna Gain Improvement

We calculated the antenna gain when the phase shifts was determined by our developed algorithm and compared with the conventional method. When the antenna element includes amplitude degradation, the optimal set of phase shifts is not always the same as the conventional phase shifts determined by cancelling the space phase factor. We calculated the maximum and average array gains when we adopted the developed algorithm and the conventional method for phase shift determination. We fixed the array size to 100 x 100, and θ and ϕ were changed from 0° to 30° by 0.1° and from 0° to 90° by 0.1°, respectively.

In the case of 4-bit cascaded phase shifter, the antenna gain was improved 0.51 dB in average and 3.19 dB at maximum by

utilizing our developed algorithm compared with the conventional method. This result means that the conventional phase shift determination provides significant ramifications of power transmission loss or beam pattern degradation when the phased array includes amplitude degradation. In the worst case, more than 50% of transmitting power will disappear only by phase shift determination. Therefore, our developed algorithm is absolutely useful for maximizing the transmitting power when the phased arrays are suffered from amplitude degradation.

V. CONCLUSION

A polynomial-time algorithm was developed to solve a large-scale phased array problem including amplitude degradation for transmitting power maximization. Our developed algorithm took less than 10 seconds to determine the phase shift of each antenna element even with one million antenna elements. We also confirmed that our developed algorithm improved the antenna gain, and that the SPS would suffer considerable transmission power loss or beam pattern degradation if the conventional phase shift determination was lightly adopted. For future works, we will verify the effectiveness of the algorithm by experimental demonstration of a one-dimensional phased array antenna.

REFERENCES

- [1] P. E. Glaser, F. P. Davidson, and K. Csigi, *Solar Power Satellites*, New York: John Wiley & Sons, 1998.
- [2] H. Matsumoto, "Research on solar power station and microwave power transmission," *IEEE Microwave Magazine*, vol. 3, pp. 36–45, Dec. 2002.
- [3] R. J. Mailloux, *Phased Array Antenna Handbook*, 2nd Ed., USA: Artech House, 2005.
- [4] M. Fakhrazadeh, P. Mousavi, S. Safavi-Naeini, and S. H. Jamali, "The effects of imbalanced phase shifters loss on phased array gain," *IEEE Antennas Wireless Propag. Lett.*, vol. 7, pp. 192–196, 2008.
- [5] T. Mitani, S. Tanaka, and Y. Ebihara, "Experimental study on one-dimensional phased array antenna including lossy digital phase shifters for transmitting power maximization," in *Proc. URSI GA*, 2011, paper CHGBDJK.6.