

Experiment of Power and Data Transmission Scheduling for Single Wireless LAN Sensor

Norikatsu Imoto, Shota Yamashita, Koji Yamamoto, Masahiro Morikura

Graduate School of Informatics, Kyoto University
Yoshida-honmachi, Sakyo-ku, Kyoto, 606-8501 Japan
 imoto@imc.cce.i.kyoto-u.ac.jp

Abstract—In wireless sensor networks, individual nodes must be batteryless to make themselves maintenance-free, which is particularly important for networks that have an enormous number of nodes. Wireless and batteryless sensors can be powered by energy harvesting or wireless power transmission, and they store energy in capacitors. Microwave power transmission is a wireless power transmission scheme that can interfere with data transmission. It necessitates scheduling of data and power transmission. In addition, to ensure network sustainability, a constant amount of energy should be stored in the capacitors. In the experiments conducted in this study, a node is not charged while transmitting data or receiving beacon signals that contains delivery traffic indication message elements (DTIM) to avoid interference. Moreover, it is powered by a solar panel to emulate microwave power transmission. In addition, sleep periods are scheduled by the node to ensure that a constant amount of energy remained in the capacitor.

I. INTRODUCTION

Smart communities, disaster prevention systems, and medical and healthcare systems are required for an ecologically sustainable and safe society [1]. These systems require a very large number of wireless sensor nodes. Hence, the wireless nodes shall be batteryless to make themselves maintenance-free [2]. Wireless and batteryless sensors can be powered by energy harvesting or wireless power transmission [3]. In this paper, microwave power transmission is assumed. Microwave power transmission is a technology that allows transmission of power via microwaves. At high power levels, microwave power transmission interferes with data transmission from the nodes even if the data transmission frequency is not exactly the same as the microwave transmission frequency at the 2.4GHz industrial, scientific, and medical (ISM) band [4]. Thus, scheduling to separate data and power transmission timing is required.

Furthermore, there are other issues, like how to keep the capacitors energy constant. When a batteryless sensor is powered by a capacitor, a DC-DC converter is required to convert the capacitor terminal voltage into the voltage required to power the sensor circuit. In general, at high input voltage, the efficiency of the DC-DC converters are high. However, the capacitor terminal voltage must be lower than the withstand voltage of the capacitor. Thus, the capacitor terminal voltage must be constant.

In this paper, as an initial study, solar power is used to charge the capacitor instead of microwave power. In the experiments, the node is not charged during communication to avoid interference, and sleep periods are scheduled to keep the capacitor terminal voltage to the withstand voltage.

In the experiments, the node alternates between active and sleep mode. In active mode, the node is in the awake state, and it can transmit data any time. In sleep mode, the node is in the doze state and enters in the awake state to listen beacon signals that contains delivery traffic indication message (DTIM) elements [5]. Thus, at estimated arrival timings of beacon signals contain DTIM elements (hereinafter, referred to as DTIM), the node must not be powered by wireless power transmission.

Related studies are shown in the literature [4], [6] and [7]. ZigBee devices are operating by intermittent microwave power transmission in [4]. In this case, the duty ratio of intermittent microwave power transmission is constant, whereas, in this paper, Wi-Fi devices are used and the duty ratio is controlled to keep the capacitor terminal voltage to withstand the voltage. The duty ratio control for energy harvesting is studied in [6]. In this paper, the sensor is not charged while transmitting data, i.e., in active mode. A model with the arrival of discrete packets of energy is considered in [7]. In this model, optimum transmission policies are also considered, and that can be implemented by controlling the transmitted bits. In contrast, in this study, sleep periods are scheduled for the node.

The paper is organized as follows. Section II describes the method used to keep the capacitor terminal voltage to the withstand voltage. Section III provides the details of experimental setup and results. Section IV concludes the paper.

II. ADAPTIVE SLEEP CONTROL

In this section, the scheme to keep the capacitor terminal voltage to the withstand voltage by controlling sleep periods is presented. The node is powered by a capacitor. Let the remaining energy in the capacitor in the k th active mode be denoted by $e[k]$. The value of $e[k]$ is measured when the node goes into active mode, and $e[k + 1]$ is managed by controlling sleep periods. Moreover, in all active modes, the node transmits data. Let $\alpha[k] \in \{0, 1, \dots, 10\}$ denote the number of power transmission signals in the k th sleep mode.

In the experiments, the node receives $\alpha[k]$ power transmission signals until the next transmission time. In addition, when $\alpha[k] = 0$, the node does not receive a DTIM until the next data transmission time. In other cases, it receives $(\alpha[k] - 1)$ DTIMs until the next data transmission time. In this paper, controlling the value of $\alpha[k]$ means to control the cycle time and sleep period, because the duration of the power transmission signal is 9.74 s and it is a constant value. Note that the duration of the k th cycle is the sum of the k th sleep period and the k th active period and that k th sleep mode precedes the k th active mode.

In the experiments, the energy consumed by the node is estimated from the node parameters and $\alpha[k]$. Let $T_\alpha[k]$ and T_{DTIM} denote cycle time and the duration of a DTIM interval. $T_\alpha[k]$ is calculated from the DTIM interval using (1):

$$T_\alpha[k] = \alpha[k]T_{\text{DTIM}}. \quad (1)$$

Let $E_\alpha[k]$ denote consumed energy in k th cycle. Moreover, let E_{tran} , E_{DTIM} , τ , and P_{doze} denote the consumed energy in data transmission, the consumed energy in receiving a DTIM, the duration of listening a DTIM, and the power consumption in doze states. These parameters are obtained from experiments. From them, $E_\alpha[k]$ is given by (2):

$$E_\alpha[k] = E_{\text{tran}} + P_{\text{doze}}(T_\alpha[k] - (\alpha[k] - 1)\tau) + (\alpha[k] - 1)E_{\text{DTIM}}. \quad (2)$$

Note that the consumed energy during switching between the active and sleep modes is assumed negligible to be confirmed by the experimental results.

In the experiments, the node estimates remaining energy in the capacitor, under the assumption it receive $\alpha[k+1]$ power transmission signals in the next sleep mode. Let $P_{\text{rec}}[k]$ denote the power supplied by the solar panel. Moreover, let $\alpha^*[k]$, $T_{\alpha^*}[k]$, and T_Δ denote the optimal $\alpha[k]$ for the chosen k th cycle, the cycle time corresponding to $\alpha^*[k]$, and the margin period to avoid interference between DTIMs and power transmission. From these parameters, $P_{\text{rec}}[k]$ is calculated using (3):

$$P_{\text{rec}}[k] = \begin{cases} \frac{(e[k] - e[k-1] + E_{\alpha^*}[k])}{\alpha[k](T_{\text{DTIM}} - T_\Delta)} & \alpha[k-1] \neq 0 \\ P_{\text{rec}}[k-1] & \alpha[k-1] = 0. \end{cases} \quad (3)$$

When $\alpha[k-1]$ is 0, the node calculates $P_{\text{rec}}[k]$ as $P_{\text{rec}}[k] = P_{\text{rec}}[k-1]$, otherwise P_{rec} is calculated as 0, and the node cannot estimate $e_\alpha[k+1]$ correctly. $\alpha[k](T_{\text{DTIM}} - T_\Delta)$ is the duration of power supply from the solar panel. Under the assumption that the power supply in the $(k+1)$ th sleep mode is the same as the supply power in the k th sleep mode, i.e., $P_{\text{rec}}[k]$, the remaining energy in the $(k+1)$ th active mode is given by the following equation:

$$e_\alpha[k+1] = e[k] + P_{\text{rec}}[k]\alpha[k+1](T_{\text{DTIM}} - T_\Delta) - E_\alpha[k]. \quad (3)$$

Fig. 1 shows estimated remaining energy in the capacitor when $\alpha[k+1] = 0, 10$, and power supply conditions when $\alpha[k+1] = 10$. While the node is in awake state, it consumes E_{DTIM} or

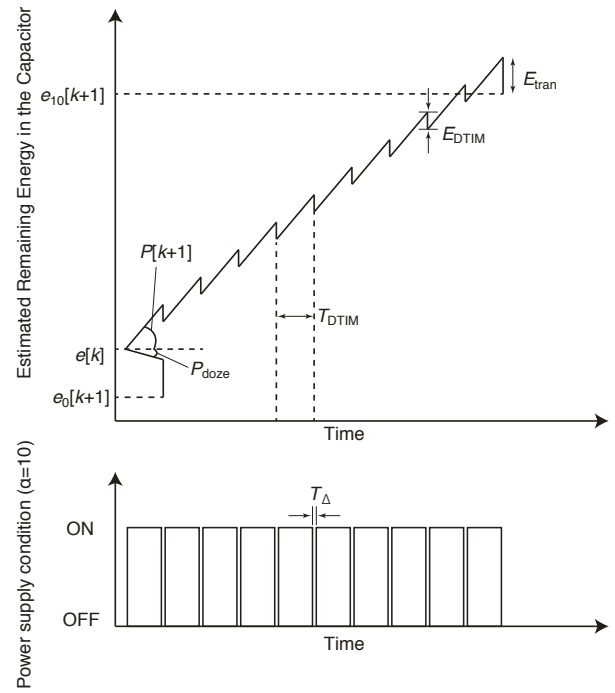

Fig. 1. Remaining energy in the capacitor estimated by the node and power transmission signals.

E_{tran} . E_{DTIM} is smaller than E_{tran} , thus, at large $\alpha[k+1]$, $e_\alpha[k+1]$ is large. When $\alpha = 0$, the node must not be powered by wireless power transmission until in next active mode.

From $e_\alpha[k+1]$, the node choose the optimum value of $\alpha[k+1]$. Let the remaining energy in the capacitor when its terminal voltage is charged to its withstand voltage be denoted by E_{max} . If $e[k]$ is sufficiently smaller than E_{max} , i.e., $e_\alpha[k+1]$ does not reach E_{max} , then $\alpha^*[k+1] = 10$. This means that if $e_{10}[k+1] < E_{\text{max}}$, then $\alpha^*[k+1] = 10$. On the contrary, if $e[k]$ is large relative to E_{max} , then $\alpha^*[k+1] = 0$. This means that if $e_0[k+1] > E_{\text{max}}$, then $\alpha^*[k+1] = 0$. In other cases, $\alpha^*[k+1]$ is given by (4):

$$\alpha^*[k+1] = \arg \min_{\alpha[k+1] \in \{1, \dots, 10\}} \{E_{\text{max}} - e_\alpha[k+1]\}. \quad (4)$$

In (4), $\alpha[k+1]$ is chosen from 1 to 10, not from 0 to 10, because we decided that $\alpha[k+1] = 0$ is chosen when $e_0[k+1]$ is large relative to E_{max} .

The node sleeps during duration of $\alpha^*[k+1]T_{\text{DTIM}}$ in the $(k+1)$ th sleep mode. As a result, $\alpha^*[k+1]$ is determined by $e[k]$ and $e[k-1]$. In addition, $e_{\alpha^*}[k+1]$ is the largest $e_\alpha[k+1]$ which is not greater than E_{max} .

III. EXPERIMENT

In this section, we conducts experiments of the scheduling proposed in section II. The node is powered by a capacitor, and the capacitor is charged by solar panel. We evaluate the relationship of the remaining energy in the capacitor and the transmission time.

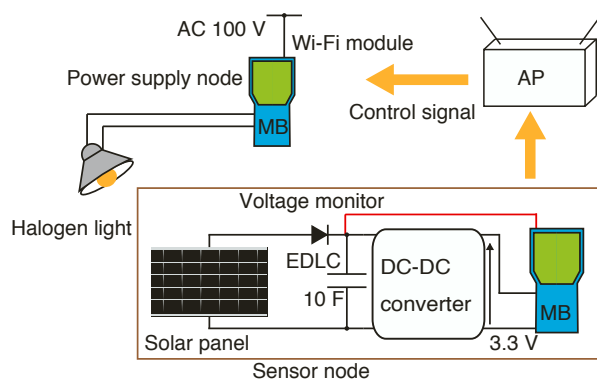

Fig. 2. Schematic diagram of experimental apparatus.

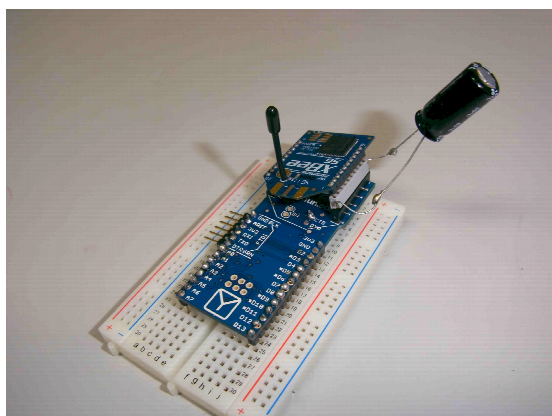

Fig. 3. XBee Wi-Fi and Arduino Fio.

 TABLE I
EXPERIMENTAL PARAMETERS.

| | |
|-------------------|----------|
| T_{DTIM} | 10.24 s |
| E_{tran} | 22.44 mJ |
| P_{doze} | 6 mW |
| E_{DTIM} | 19.14 mJ |
| τ | 40 ms |
| T_{Δ} | 500 ms |

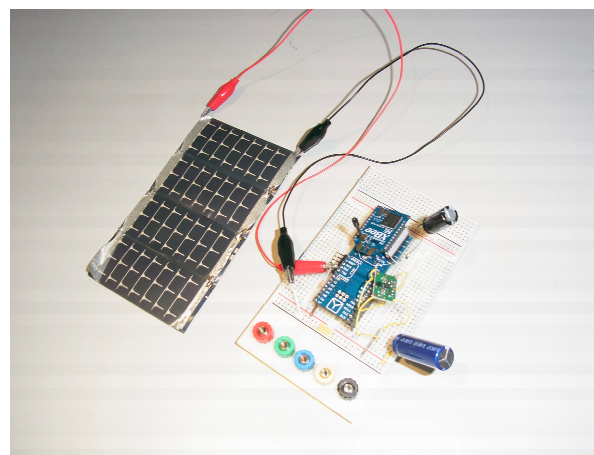

Fig. 4. Sensor node powered by a solar panel.

The sensor node operates as shown in Fig. 5. The MB and the Wi-Fi module are in the sleep mode when the EDLC is charged by the solar panel. After the light is turned off, the MB and the Wi-Fi module get into active mode. The MB measures the EDLC terminal voltage, and determines the value

A. Setup

The experiments are conducted by using the setup shown in Fig. 2. In the experiments, the system consists of an access point (AP) and two nodes: a sensor node and a power supply node. The sensor node is equipped with a Texas Instruments TPS61200 DC-DC converter, a wireless module, a diode, a solar panel, and a 10 F Electric double-layer capacitor (EDLC) with a withstand voltage of 2.7 V. The wireless module consists of a Wi-Fi module, and a programmable microcontroller board (MB). The Wi-Fi module is a Digi International XBee Wi-Fi operated by the IEEE 802.11g protocol. The microcontroller board is Sparkfun Electronics Arduino Fio, which can be connected to XBee Wi-Fi, as shown in Fig. 3. Both the Wi-Fi module and the MB run at 3.3 V. Note that current for the wireless module is almost 140 mA in the active mode and awake state, 2 mA in the doze state. Other parameters are shown in Table I. These parameters obtained from experiments. In the experiments, solar power is supplied to the EDLC instead of microwave power, as shown in Fig. 4. The solar panel is connected to the EDLC through the diode, which prevents a reverse current flow. The sensor node transmits control signals to the power supply node via the AP, and informs DTIM arrival timings.

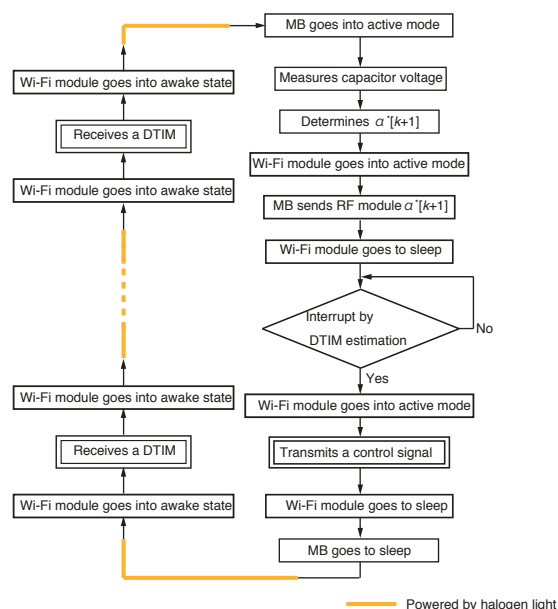

Fig. 5. Sensor node operation.

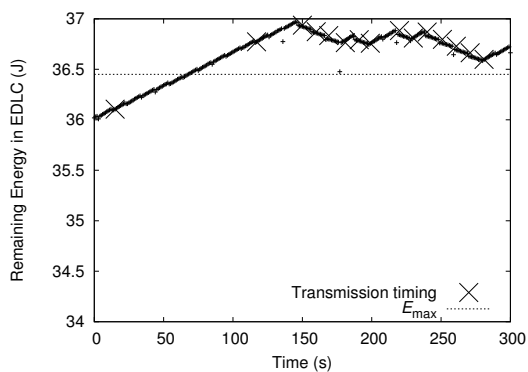

Fig. 6. Remaining energy in the EDLC.

$\alpha^*[k+1]$, and waits until the estimated DTIM arrival timings. When the estimated DTIM arrival timings, the Wi-Fi module goes into awake states. The Wi-Fi module receives a DTIM and transmits the control signals to the power supply node to generate $\alpha^*[k+1]$ power transmission signals. After the Wi-Fi module and the MB go into sleep mode, the light is turned on. While in sleep mode, at the estimated DTIM arrival timings, the Wi-Fi module goes into awake states and listen DTIMs. In this DTIM periods, light is turned off. As a result, scheduling of data transmission and power transmission is successfully conducted by controlling the light.

B. Results

The experimental results are shown in Fig. 6. The remaining energy in the EDLC converges toward almost 36.8J. The sensor node measures voltage within an error of almost 3%. It measures the EDLC terminal voltage $e[k]$ within an error of almost 0.48%. While the EDLC terminal voltage is high, the value of α is chosen from 0, 1, or 2. At the first transmission time, the value of α is 10, because the EDLC terminal voltage is low enough.

In addition, the scheduling of data and power transmission is conducted. Fig. 7 shows an example of the current consumed by the node and the power supply condition. In Fig. 7, the node transmits data at around 10 s, 20 s, and 40 s. In each sleep periods, the node receives 0, 2, and 1 of power transmission signals.

IV. CONCLUSION

To emulate microwave power transmission, a sensor node powered by a solar panel was designed to manage its remaining energy by controlling its sleep periods. In addition, the power supply from the solar panel was 12.2 mW. This power level can be supplied by wireless power transmission. In addition, timing of power transmission and data transmission are successfully separated.

ACKNOWLEDGMENT

This work is supported in part by a Grant-in-Aid for Scientific Research (B) (no. 24360149).

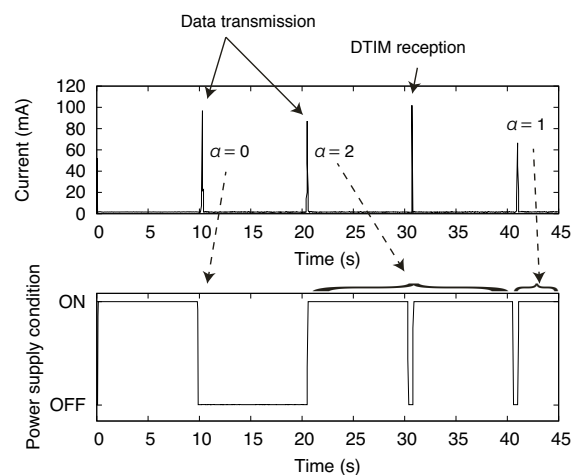

Fig. 7. Consumption current of the node and power supply condition

REFERENCES

- [1] X. Ren-wu, "Smart grid in residential power utilization field," *2010 China International Conference on Electricity Distribution*, Sep. 2010.
- [2] M. Gatzianas, L. Georgiadis, and L. Tassiulas, "Control of wireless networks with rechargeable batteries," *IEEE Trans. Wireless Commun.*, vol. 9, no. 2, pp. 581–592, Feb. 2010.
- [3] N. Shinohara, "Power without wires," *IEEE microwave magazine*, pp. S64–S73, Dec. 2011.
- [4] T. Ichihara, T. Mitani, and N. Shinohara, "Study on intermittent microwave power transmission to a zigbee device," *IMWS-IWPT2012, FRI-G-2*, pp. 209–212, May 2012.
- [5] *IEEE Std 802.11-2007: Part 11: Wireless LAN medium access control (MAC) and physical layer (PHY) specifications*, 2007.
- [6] A. Kansal, J. Hsu, S. Zahedi, and M. B. Srivastava, "Power management in energy harvesting sensor networks," *ACM Transactions on Embedded Computing System*, vol. 6, no. 4, Sep. 2007.
- [7] K. Tutuncuoglu and A. Yener, "Optimum transmission policies for battery limited energy harvesting nodes," *IEEE Trans. Wireless Commun.*, vol. 11, pp. 1180–1189, Mar. 2012.