

A Highly Isolated Transmission Line Employing a Periodic Ground Structure on MMIC For an EMC Solution

Se-Ho Kim^{#1}, Young-Bae Park^{#2}, Suk-Youb Kang^{#3}, Min-Hyuk Kim^{#4}, Nam-Soo Kim^{#5}, Ji-Won Jung^{#6}, Young Yun^{#7}, Kyu-Ho Park^{#8}, Jin-Sup Kim^{#9}, Ki-jin Kim^{#10}, Se-Hwan Choi^{#11} and Kwang-Ho Ahn^{#12}

[#] Radio Communication Engineering, Korea Maritime University, Korea
1, Dongsam-dong, Youngdo-gu, Busan, Korea

¹djflsl213@paran.com, ²redphoenix@empal.com, ³int-ksy@hanmail.net, ⁴golden80@nate.com

⁵skatn1983@hhu.ac.kr, ⁶jjjung@hhu.ac.kr, ⁷yunyoung@hhu.ac.kr

^{*} Korea Electronics Technology institute

#68, Yatap-dong, Bundang-gu, Seongnam-si, Gyeonggi-do, 463-816, Korea

⁸parkkh@keti.or.kr, ⁹kim81@keti.or.kr, ¹⁰sergeant@keti.re.kr, ¹¹shchoi@keti.re.kr, ¹²khajoh@keti.re.kr

Abstract— Using a periodic ground structure (PGS) on GaAs monolithic microwave integrated circuit (MMIC), a microstrip line structure with a high isolation characteristic between lines was developed for an EMC solution on MMIC. The high isolation characteristic was originated from a resonance between adjacent microstrip lines employing PGS. According to experimental results, a much better isolation characteristic was observed from the adjacent microstrip lines employing PGS compared with conventional microstrip lines, and the frequency range for high isolation was easily controlled by changing the PGS structure. Above results indicate that microstrip lines employing PGS are very useful for application to compact signal lines of highly integrated MMIC requiring a severe EMC regulation.

Key words: Microstrip line, periodic ground structure (PGS), electromagnetic compatibility (EMC), Monolithic Microwave integrated Circuit (MMIC).

I. INTRODUCTION

With a rapid development of information and communication industry, the interests in the EMI (electromagnetic interference) and EMS (electromagnetic susceptibility) are gradually increasing for an improvement of electromagnetic environment [1-5]. Especially, a reduction of electromagnetic coupling has become an hot topic in EMC (electromagnetic compatibility) problem, because it causes a serious trouble in communication system.

In this work, using periodic ground structure (PGS), microstrip line structure with a high isolation characteristic was developed for application to compact signal lines of highly integrated MMIC (Monolithic Microwave Integrated Circuits). In addition, the origin of the high isolation characteristic between microstrip lines employing PGS was theoretically analyzed using an equivalent circuit.

II. RESONANCE CHARACTERISTIC OF COUPLED MICROSTRIP LINE EMPLOYING PGS

Many articles on periodic structures such as PBG (Photonic Band Gap) and metamaterial have been recently reported for a

development of miniaturized passive components[6, 7]. However, periodic structure concerning an EMC solution has not published yet. In this work, microstrip line employing PGS was developed for a high isolation characteristic.

Fig. 1 shows a coupled microstrip line employing PGS. The PGS was inserted at the interface between SiN film and GaAs substrate, and the PGS serves as ground plane because it was electrically connected to backside ground metal through the via-holes. We can deduce that the above structure shows high isolation characteristics from equivalent circuit. Fig. 2 shows the equivalent circuit of adjacent two lines, which corresponds to the equivalent circuit of the N^{th} unit section of the periodic structure surrounded by rectangular box in Fig.1. C_b corresponds to the capacitance between top line and PGS, which is shown in Fig. 1, and it is proportional to the cross area WT of line and PGS (As shown in Fig. 1(a), W and T are the width of top lines and the periodic strips of PGS, respectively). R_g and L_g are resistance and inductance originating from the loss and current flow of the periodic strip of PGS with width T , respectively. C_g corresponds to the capacitance between PGS and backside metal of GaAs substrate. L_p is parasitic inductance originating from via holes. C_c is coupling capacitance between adjacent lines. The impedance Z between the adjacent two lines of the N^{th} unit section (between port 1_N and port 2_N of Fig. 2) can be given by,

$$Z = \frac{2}{j\omega C_c} \left\{ \frac{\frac{2L_g + L_p}{C_b} - \omega^2 L_g \cdot (L_g + L_p) \cdot \left(\frac{C_g}{C_b} + 1 \right)}{\frac{2L_g + L_p}{C_{bc}} - \omega^2 L_g \cdot (L_g + L_p) \cdot \left(\frac{C_g}{C_{bc}} + 2 \right)} \right\} \quad (1)$$

$$\frac{1}{C_{bc}} = \frac{1}{C_c} + \frac{2}{C_b}$$

From the above equation, we can see that the circuit structure of Fig. 2 shows a resonance characteristic at the frequency where the denominator of the above equation becomes zero, and the resonance frequency can be expressed as,

$$f_c = \frac{1}{2\pi} \sqrt{\left(\frac{1}{L_g} + \frac{1}{L_g + L_p}\right) \cdot \frac{1}{(C_g + 2C_{bc})}} \tag{2}$$

$$\approx \frac{1}{2\pi} \sqrt{2 \left(\frac{1}{L_g} + \frac{1}{L_g + L_p}\right) \left(\frac{1}{C_c} + \frac{2}{C_b}\right)}$$

, where C_g was ignored because C_g is much less than C_{bc} due to much thicker GaAs substrate than SiN film. Fig. 3 shows the calculated insertion loss of the equivalent for the unit section of PGS structure with $T = 5 \mu\text{m}$ and $S = 20 \mu\text{m}$, and the circuit parameters correspond to the followings. As expected, we can observe a resonance characteristic in the vicinity of 60 GHz. The above results indicate that the coupled line employing PGS has a resonance characteristic innately, and the isolation between microstrip lines employing PGS is highly improved in the vicinity of resonance frequency in comparison with conventional microstrip lines

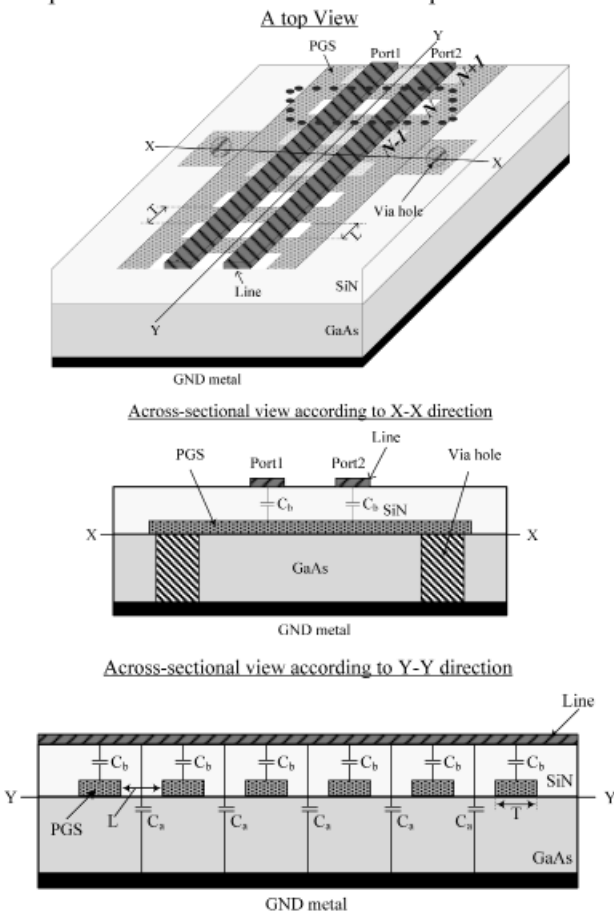

Fig. 1 Coupled microstrip line structure employing PGS.

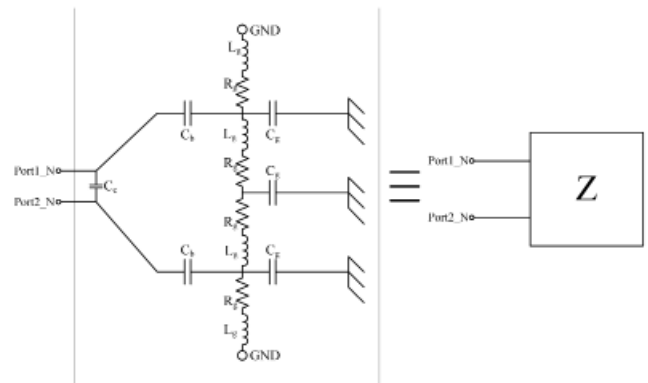

Fig. 2 An equivalent circuit for a unit section of the adjacent two lines of coupled microstrip employing PGS.

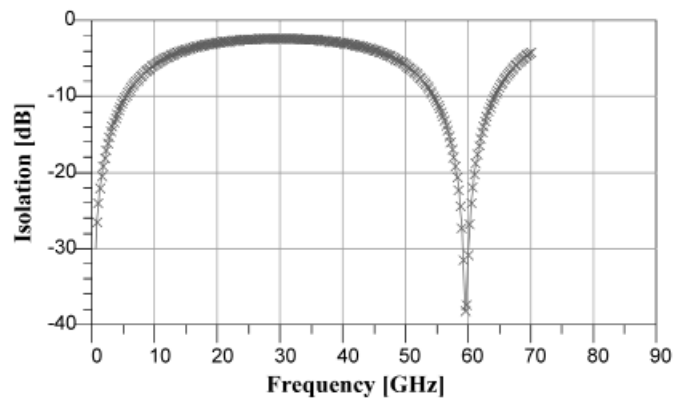

Fig. 3 Calculated isolation characteristic of the equivalent circuit for a unit section of the adjacent two lines with $T = 5 \mu\text{m}$ and $S = 20 \mu\text{m}$.(see Fig. 2)

III. ISOLATION CHARACTERISTIC OF THE MICROSTRIP LINE EMPLOYING PGS

Port 1 Port 2

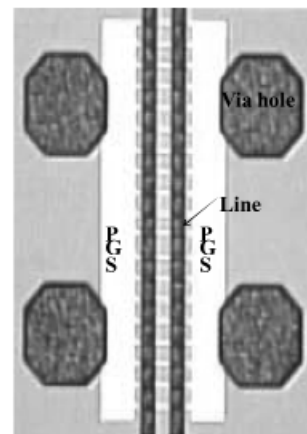

Fig. 4 A photograph of coupled microstrip line structure employing PGS.

We fabricated coupled microstrip lines employing PGS. Fig. 4 shows a photograph of the coupled microstrip line employing PGS. In this structure, W , S and L are all $20 \mu\text{m}$, and SiN and GaAs substrate thickness are 0.1 and $100 \mu\text{m}$, respectively. The measured isolation characteristic S_{12} between port 1 - 2 are shown in Fig. 5, where the isolation characteristic between conventional microstrip lines without PGS was also included for comparison, and W and S for the conventional microstrip

lines are all 20 μm , respectively. As expected, we can observe the resonance characteristics in the measured results for the PGS structure, which results in much better isolation characteristics than conventional one. Especially, highly improved isolation characteristics are observed in the vicinity of resonance frequency. Concretely, with only a spacing of 20 μm , the coupled microstrip line employing PGS shows an isolation value of -47 dB at 60 GHz. On the other hand, the conventional coupled microstrip line without PGS shows an isolation value of -8 dB at 60 GHz. Fig. 6 shows measured isolation characteristic S_{12} of the coupled microstrip line employing PGS with various values of T . As shown in Fig. 6, as T (see T in Fig. 1) is increased, the resonance frequency becomes lower. This result can be easily explained from Eq. (2). As explained before, C_b is proportional to the cross area $W \cdot T$ of line and PGS shown in Fig. 1 (a), and an increase of T leads to an increase of C_b . Therefore, from Eq. (2), we can easily deduce that an increase of T results in a decrease of resonance frequency. Above result indicates that the resonance frequency can be easily controlled by only changing T , which makes the resonance frequency easily tuned to the signal coupling frequency for a suppression of coupling between lines. This makes the PGS structure very attractive for application to compact signal lines of highly integrated IC.

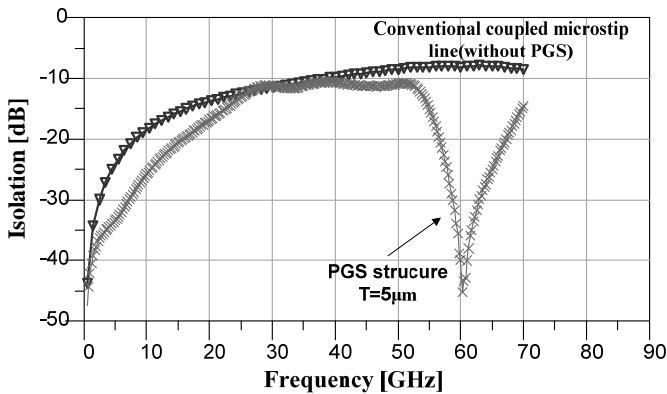

Fig. 5 Measured isolation characteristic S_{12} of the coupled microstrip line employing PGS and conventional coupled microstrip line.

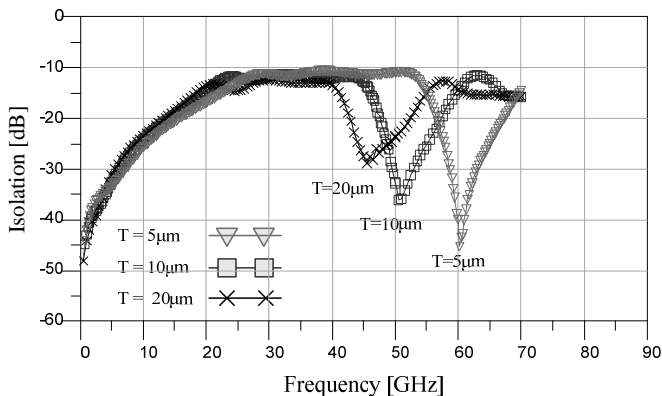

Fig. 6 Measured isolation characteristic S_{12} of the coupled microstrip line employing PGS with various values of T .

IV. AN EXTRACTION OF EQUIVALENT CIRCUIT AND CLOSED-FORM EQUATION OF THE COUPLED MICROSTRIP LINE EMPLOYING PGS

The equivalent circuit and closed-form equation of the coupled microstrip line employing PGS should be extracted for application to circuit design. Fig. 7 shows an equivalent circuit of the coupled microstrip line employing PGS, and its photograph is shown in Fig. 4. As shown in this figure, a number of the equivalent circuits of unit section (see Fig. 2) are connected to each other, and via hole was expressed as lumped inductor. The capacitance and inductance of the equivalent circuit are given by,

$$C_b = \left[0.019 + \left(\frac{T}{d_i} \right) \times 7 \times 10^{-5} - \left(\frac{T}{d_i} \right)^2 \times 2 \times 10^{-7} \right] (pF) \quad (3)$$

$$C_g = \frac{T}{d_s} \times 10^{-3} (pF) \quad (4)$$

$$L_g = \frac{l_s}{T} \times 1.875 \times 10^{-3} (nH) \quad (5)$$

$$R_g = \frac{l_s}{T} \times 3.125 \times 10^{-2} (\Omega) \quad (6)$$

,where d_i , d_s and l_s are thickness of SiN film, thickness of semiconducting substrate and length of PGS strip, respectively. In this work, d_s and l_s are 100 and 80 μm , respectively. For a comparison, measured and calculated isolation characteristics of the microstrip line employing PGS with $T = 5$ and 10 μm are shown in Fig. 8 (a) and (b). For the calculation results, equivalent circuit of Fig. 7 and closed-form equation of (3) – (6) were employed. As shown in this figure, we can observe a fairly good agreement between measured and calculated result.

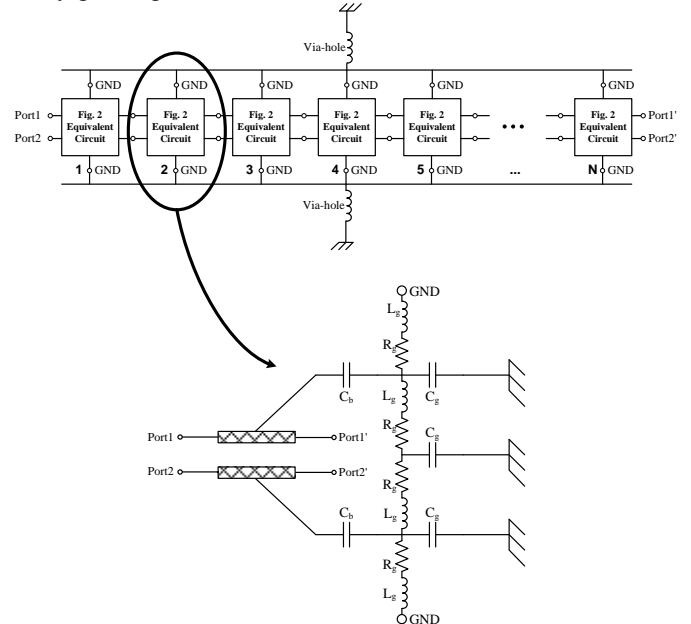

Fig. 7 Equivalent circuit for coupled microstrip line employing PGS with n -units sections.

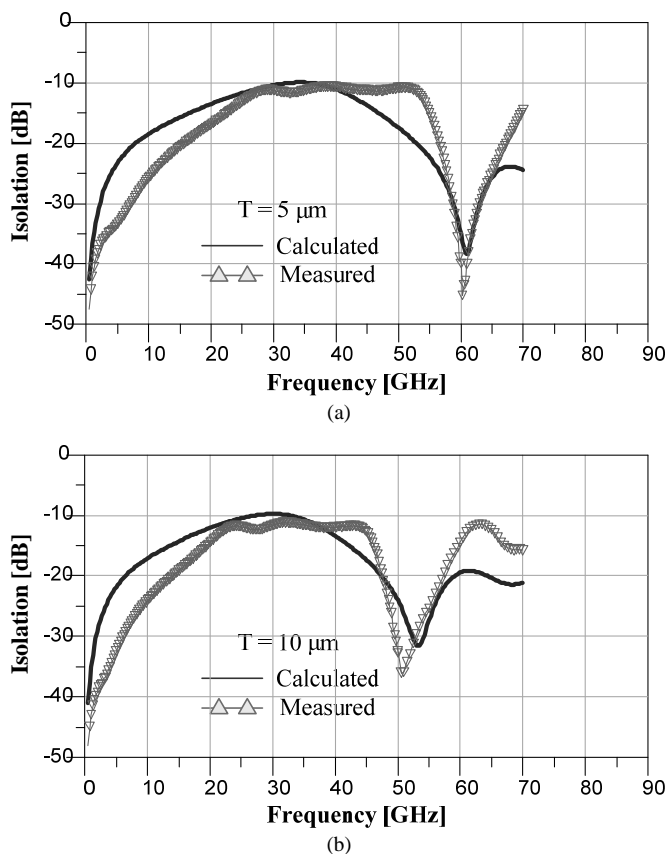

Fig. 8 (a) Measured and calculated isolation characteristic S_{12} of the coupled microstrip line employing PGS ($T = 5 \mu\text{m}$) and (b) Measured and calculated isolation characteristic S_{12} of the coupled microstrip line employing PGS ($T = 10 \mu\text{m}$)

V. CONCLUSION

Using the PGS, microstrip line structure with a high isolation characteristic was developed for an EMC solution on MMIC, and the origin of the high isolation characteristic was theoretically investigated. With only a spacing of $20 \mu\text{m}$, the coupled microstrip line employing PGS showed an isolation value of -47 dB at 60 GHz . On the other hand, the conventional coupled microstrip line without PGS showed an isolation value of -8 dB at 60 GHz . According to the theoretical analysis, it was found that the innate resonance characteristic originating from the parasitic elements of PGS structure enabled a high isolation characteristic. Especially, the isolation characteristic was highly improved in the vicinity

of resonance frequency, and the resonance frequency could be easily controlled by only changing T , which made the resonance frequency easily tuned to the signal coupling frequency for a suppression of coupling between lines. Above results indicate that microstrip lines employing PGS are very useful for application to compact signal/bias lines of highly integrated MMIC requiring a severe EMC regulation.

ACKNOWLEDGMENTS

This work was supported by the Korean Ministry of Education, Science and Technology Grant (The Regional Core Research Program/Institute of Logistics Information Technology), and also partly supported by KETI (Korea Electronics Technology Institute). This research was supported by MKE, Korea, under the ITRC support program supervised by the IITA(IITA-2008-C1090-0804-0007) and this work was supported by DAPA and ADD under the contract UD070054AD. This work was also partly supported by ETRI SoC Industry Promotion Center, Human Resource Development Project for IT SoC Architect.

REFERENCES

- [1] Uusimaki, M., and Renko, A., "A systematic approach and comparison of different 3-D chip structures for electromagnetic compatibility", *Electromagnetic Compatibility, 2004. EMC 2004. 2004 International Symposium on Vol. 2*, pp. 734 - 739, 9-13 Aug. 2004
- [2] Adan, A.O. Fukumi, M. Higashi, K. Suyama, T. Miyamoto, M. Hayashi, M., "Electromagnetic coupling effects in RFCMOS circuits", *Microwave Symposium Digest, 2002 IEEE MTT-S International*, Seattle, WA, USA, vol.1, pp. 39-42, 2-7 June 2002
- [3] Ramdani, M., Sicard, E., Ben Dhia, S., Catrysse, J., "Towards an EMC roadmap for Integrated Circuits", *Electromagnetic Compatibility and 19th International Zurich Symposium on Electromagnetic Compatibility, 2008, APEMC 2008, Asia-Pacific Symposium on*, pp. 8 - 11, 19-23 May 2008
- [4] G. Kurizki and A. Z. Genack, "Suppression of molecular interactions in periodic dielectric structures," *Physics Review Letters*, vol. 61, no. 19, pp. 2269-2271, Nov. 1988.
- [5] Yee Hui Lee, Shao Ying Huang, "Electromagnetic compatibility of a dual-planar electromagnetic band-gap microstrip filter structure", *Electromagnetic Compatibility, 2006. EMC-Zurich 2006, 17th International Zurich Symposium*, pp. 561 - 564, 27 Feb.-3 March 2006
- [6] A. Lai, and T. Itoh, "Microwave composite right/left-handed metamaterials and devices," in *Proc. Asia-Pacific Microwave Conf.*, Suzhou, China, Dec. 2005, pp. 31-34.
- [7] A. S. Andrenko, Y. Ikeda, and O. Ishida, "Application of PBG microstrip circuits for enhancing the performance of high-density substrate patch antennas," *Microwave Opt. Tech. Lett.*, vol. 32, no. 5, pp. 340-344, Mar. 2002.