

Channel estimation method using MSK signals for MIMO sensor

Keita Ushiki, Kentaro Nishimori, Tsutomu Mitsui* and Nobuyasu Takemura

Graduate School of Science and Technology, Niigata University, Samsung Yokohama Laboratories

Ikarashi 2-nocho 8050, Nishi-ku Niigata-shi, 950-2181 Japan

Email : ushiki@gis.ie.niigata-u.ac.jp, nishimori@ie.niigata-u.ac.jp

Abstract—We have proposed an intruder detection method by using Multiple Input Multiple Output (MIMO) channel. Although the channel capacity on the MIMO transmission is severely degraded in time variant channels, we can take advantage of this feature *MIMO Sensor* applications. We have already demonstrated the effectiveness of MIMO sensor using wireless LAN signals at 2.4GHz band. On the other hand, the transceiver should be simplified from a point of view on power saving. In this paper, we deal a narrowband Minimum Shift Keying (MSK) which is used in RF-ID and so on, and propose a signal synchronization method for the channel estimation using the narrowband MSK signal. Moreover, the basic performance by the proposed channel estimation method is verified when considering the intruder detection by MIMO sensor.

Index Terms—MIMO sensor, minimum shift keying, frequency offset, time correlation

I. INTRODUCTION

Reliable security systems have been recently attracted much attention. Microwave sensors using existing signals, such as Frequency Modulation (FM), Television (TV) broad-casts signals and so on, have been studied, because the microwave sensors can detect the signal even in Non Line of Sight (NLOS) environment unlike conventional infrared light and camera for security usage. The microwave sensor by using received signal strength indicator (RSSI) of wireless LAN based detection method etc, are proposed [1]. This method is relatively simple but there is an issue for the detection accuracy [2]. In order to solve this problem, an intruder detection using array signal processing proposed [2][3]. In this method, Single Input Multiple Output (SIMO) channel is assumed and the variation of 1st eigenvector, which is obtained by the correlation matrix of the received signal, is utilized as a cost function of intruder detection.

We proposed an intruder detection method which utilizes channel matrix in Multiple Input Multiple Output (MIMO) channels [4], in order to enhance detection performance in [2]. We call this method *MIMO Sensor* [5]. Although the channel capacity on the MIMO transmission is severely degraded in time variant channels [6], we can take advantage of this feature in MIMO Sensor applications. Since not only receiving but also transmitting diversity effects are obtained by using MIMO transmission, higher reliability for the intruder detection is expected by using the MIMO Sensor compared to the SIMO sensor [5].

IEEE802.11n based Wireless LAN signals are used for the

evaluation on the MIMO sensor [5], because MIMO-OFDM system has been incorporated into IEEE802.11n standard and channel state information (CSI) for the MIMO channel can be easily obtained when considering MIMO-OFDM system. On the other hand, the transceiver should be simplified from a point of view on power saving. Hence, we introduce narrowband signals into the MIMO sensor. Generally speaking, differential detection is employed for the narrowband signals because the transmission rate is low and large carrier and timing offsets between the transmitter and receiver exist. Hence, the performance of CSI estimation is severely degraded if an accurate carrier and timing offset compensation is not employed. In this paper, we propose a synchronization method of carrier and timing offsets for the CSI estimation by narrowband minimum shift keying (MSK) signals, which are used in RF-ID systems.

The remainder of this paper is organized as follows. Section III shows the principle of MIMO sensor. The new synchronization method of carrier and timing offsets using MSK signals is explained in Section III. Section V shows effectiveness of the new method by the measurement for the intruder detection.

II. PRINCIPLE OF MIMO SENSOR

Fig. 1 shows a concept of MIMO sensor [5]. Fig. 1(a) and (b) compare the variation of channel matrix in the MIMO channel due to a person. Although the channel capacity of MIMO transmission is severely degraded in the time variant channels [6], we utilize the variation of channel matrix in MIMO channel as an input of *Sensor*. When M and N are the numbers of transmitting and receiving antennas, the channel matrix $\mathbf{H} \in \mathbb{C}^{N \times M}$ is changed to $\mathbf{H}' \in \mathbb{C}^{N \times M}$ due to the intrusion by the person. We realize the intrusion detection by checking the variation of the channel matrix, \mathbf{H} . The variation of the channel matrix can be expressed by time correlation function. Let us assume that $h_{no,ij}$ ($i = 1 \sim N, j = 1 \sim M$) is a component at the channel matrix without people in the room. When $h_{ij}(t)$ is a component of the channel matrix at

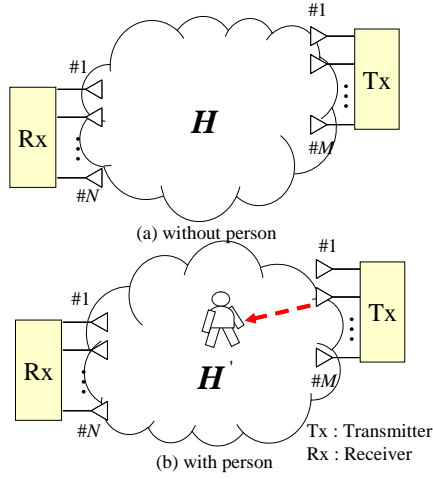

Fig. 1. Concept of MIMO sensor (Tx:Transmitter, Rx:Receiver).

time t , the time correlation, $\rho_H(t)$ is represented by

$$\rho_H(t) = \frac{\left| \sum_{i=1}^N \sum_{j=1}^M h_{no,ij}^* h_{ij}(t) \right|}{\sqrt{\sum_{i=1}^N \sum_{j=1}^M |h_{no,ij}|^2} \sqrt{\sum_{i=1}^N \sum_{j=1}^M |h_{ij}(t)|^2}}. \quad (1)$$

III. CHANNEL ESTIMATION METHOD BY USING MSK SIGNALS

Although the transceiver is simplified by using narrowband signal, large frequency and timing offsets arise due to local oscillators, A/D and D/A converters between transmitters and receivers. Fig. 2 shows an example of sliding correlation when considering the frequency offset. In order to detect the initial timing of data packet, the sliding correlation between *known* transmit and receive signals is employed in IEEE802.11n based MIMO-OFDM system [7]. Since the transmission rate is very high compared to the frequency offset in MIMO-OFDM system, the sliding correlation is effective for detecting the initial timing of data packet [7]. We measured that 14.1° per symbol is observed when the transceiver for RF-ID system is used where the frequency is 440 MHz and symbol rate is 2.4KHz [8]. The peak should be observed when the sample number is 17 in Fig. 2. The peak of sliding correlation cannot be obtained at the sample number of 17 when considering the phase offset per symbol is 15° while the sliding correlation is properly employed without the frequency offset. Hence, the accurate signal synchronization method for frequency and timing offset required when using the narrowband signals.

In this paper, the feature of MSK signals is utilized for the accurate signal synchronization. Fig. 3 shows the signal format for channel estimation and its phase variation using the MSK signals. In order to discriminate the signals from transmitter 1 (Tx1) and 2 (Tx2), different unique words (UWs,

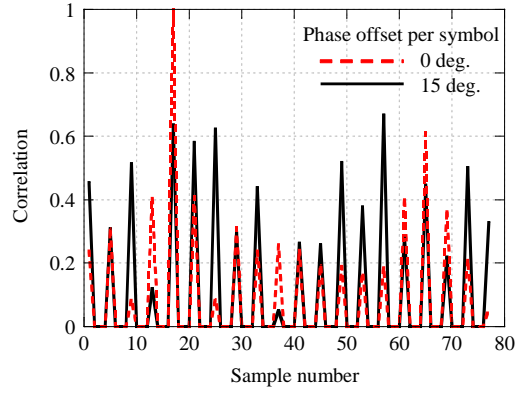

Fig. 2. Example of sliding correlation with carrier offset.

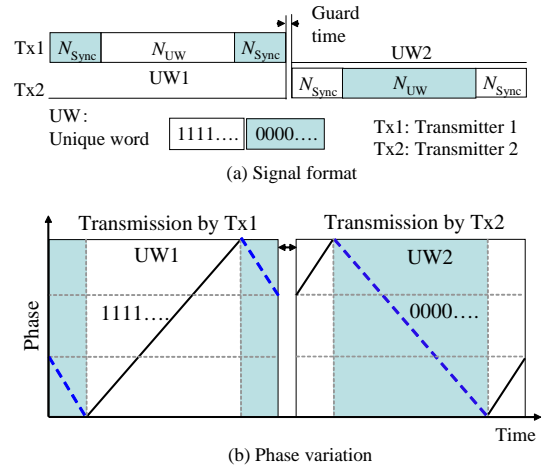

Fig. 3. Signal format for channel estimation and its phase variation.

UW1 and UW2) are assigned for Tx1 and Tx2, respectively. Since the phase variation is $\pi/2$ ($-\pi/2$) per symbol for a bit "1" ("0"), the phase variations are plus and minus for UW1 and UW2, respectively, and the signals from Tx1 and 2 can be discriminated at the receivers.

Since it is very difficult to obtain the initial timing of data packet as shown in Fig. 2, the phase variations on the previous and next data bits for UW1 and UW2 are reversed as shown in Fig. 3. By preparing the data format in Fig. 3, the initial timing and phase variation of UW1 and UW2 can be accurately obtained. N_{UW} and N_{Sync} denote the number of bits for UW and signals of reversed phase variation.

After the detection on initial timing of UW1 and UW2, the frequency offset is employed by using the phase variations on UW1 and UW2. Fig. 4 shows the phase difference between transmit and receive signals for UW1. Since the accurate phase variation on UW1 is $\pi/2 \cdot N_{UW}$, the phase difference per symbol, $\Delta\theta_1$ is $\Delta\theta_1 = (\theta_1 - (\pi/2) \cdot N_{UW})/N_{UW}$ when the actual phase variation is θ_1 . In the proposed method, the

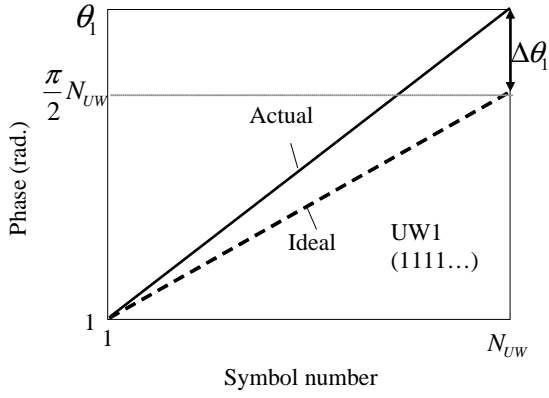

Fig. 4. Phase difference between transmit and receive signals (UW1).

following equation is used instead of this equation:

$$\Delta\theta_1 = \frac{1}{N_{UW} - 1} \sum_{t=1}^{N_{UW}-1} (\theta_1(t+1) - \theta_1(t)) - \frac{\pi}{2}, \quad (2)$$

where $\theta_1(t)$ denotes the phase at the time t . After the calculation of Eq.(4), the received signal, $r(t)$ at the time t is compensated as

$$r'(t) = r(t) \exp(-j \cdot \Delta\theta_1 \cdot t) \quad (3)$$

where $r'(t)$ denotes a compensated signal at the time t . Regarding UW2, the phase difference, $\Delta\theta_2$ due to the frequency offset is obtained by using $\pi/2$ instead of $-\pi/2$ on the second term of right side in Eq.(2).

The timing offset arises as the phase difference on the initial timing of UW1 and UW2 after the compensation on frequency offset. When the phase due to timing offset is T_{s_j} , the compensated signal, $r''(t)$ is denoted as

$$r''(t) = r'(t) \exp(-j \cdot \Delta T_{s_j}) \quad (j = 1, 2). \quad (4)$$

After the compensation of the frequency and timing offsets, the channel estimation is employed. When the signals for UW1 and UW2 are $s_{UW1}(t)$ and $s_{UW2}(t)$, the estimated channel, \tilde{h}_{ij} ($i = 1 \sim 2, j = 1 \sim 2$) are denoted as

$$\tilde{h}_{i1} = \sum_{t=1}^{N_{UW}} \frac{r(t) \exp(-j \cdot \Delta\theta_1 \cdot t) \exp(-j \cdot \Delta T_{s_1})}{N_{UW} \cdot s_{UW1}(t)}, \quad (5)$$

$$\tilde{h}_{i2} = \sum_{t=1}^{N_{UW}} \frac{r(t) \exp(-j \cdot \Delta\theta_2 \cdot t) \exp(-j \cdot \Delta T_{s_2})}{N_{UW} \cdot s_{UW2}(t)}. \quad (6)$$

IV. INTRUDER DETECTION PERFORMANCE BY PROPOSED METHOD

In order to confirm the effectiveness of proposed channel estimation method, we conducted the measurement for the intruder detection. The measurement environment is shown in Fig. 5. A person moved the courses A to D in Fig. 5. The total measurement time was 14 sec. and the features on courses A to D are as follows:

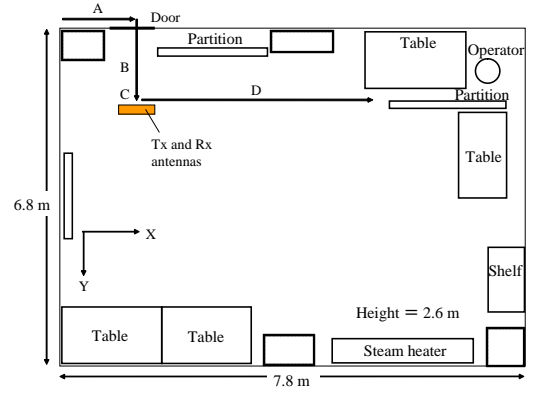

Fig. 5. Measurement environment.

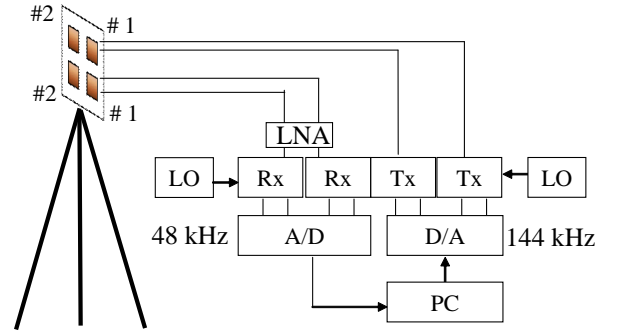

Fig. 6. Setup of antennas and transceiver for measurement.

- (A) The person moves across corridor and opens door with 4 sec.
- (B) After opening door, the person moves to the antennas across Y-axis with 3 sec.
- (C) The person changed the direction from Y-axis to X-axis with 2 sec.
- (D) The person moves to the operation across X-axis with 5 sec.

Fig. 6 shows the setup of antennas and transceiver for the measurement. The measurement parameters are shown in Table I. In order to confirm the effectiveness of proposed method, local oscillator and clock by Tx is independently employed with those by Rx. As shown in Fig. 6, the transmit and receive antennas for Tx and Rx are set up and down. As the antenna element, micro strip antenna is adopted and its 3-dB beam width is approximately 80° . The element spacing of the array antenna is one wavelength. N_{UW} and N_{Sync} in Fig. 3 are 8 and 2, respectively.

In order to clarify the basic performance of proposed method, the time correlation characteristics without people is plotted in Fig. 7. The results without and with signal synchronization (compensation of signal) are shown in Fig. 7. As can be seen in Fig. 7, the time correlation is changed even in the static environment. On the other hand, the time correlation is approximately one regardless of the measurement time by

TABLE I
PARAMETERS FOR MEASUREMENT.

Frequency	2.4 GHz band
Bandwidth	12kHz
Sampling rate (D/A)	144 kHz
Sampling rate (A/D)	48 kHz
Transmit power	-10dBm
Modulation scheme	MSK

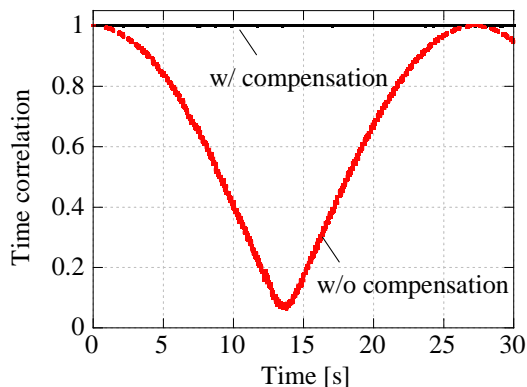

Fig. 7. Time correlation characteristics without people.

applying the proposed method.

Figs.8 and 9 shows the time correlation versus the measurement time without and with signal synchronization (compensation of signals). Eq.(1) is used to obtain the time correlation. As can be seen in Fig.8, the time correlation becomes low according to the time. Since the antenna is directed toward the end-fire direction when the person walks around the final point of D, it is difficult to detect the change on the propagation channel due to the person. Hence, the correlation should be approximately one at the final point of D, and the correlation is approximately one as shown in Fig.9. Moreover, the time correlation is changed according to the situation on the courses

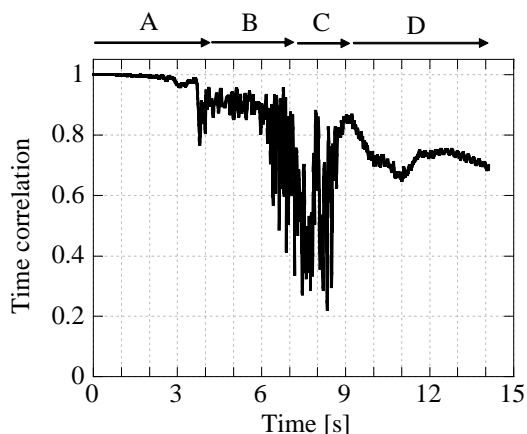

Fig. 8. Time correlation characteristics with an intruder (w/o compensation).

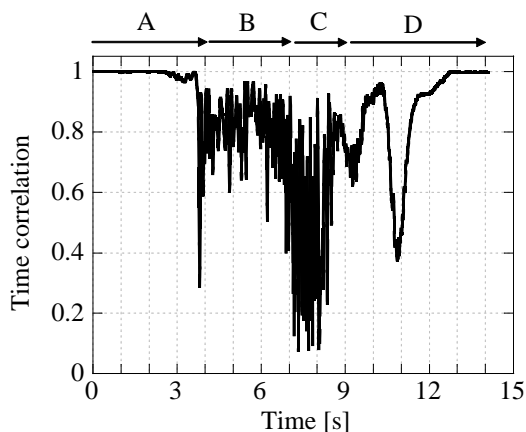

Fig. 9. Time correlation characteristics with an intruder (w/ compensation).

A to B when the proposed method is employed. Therefore, it is shown that the proposed method can accurately estimate the change on the propagation channel due to the person.

V. CONCLUSION

This paper has proposed the signal synchronization method for the channel estimation using the narrowband MSK signals. The proposed method realizes the signal synchronization by giving the reversal of phase variation on front and back of unique word even in a severe condition on frequency and timing offsets between transmitters and receivers. Moreover, it is shown that the proposed channel estimation method is effective when considering the intruder detection by MIMO sensor.

ACKNOWLEDGEMENT

The part of this work was supported by S1 Corporation.

REFERENCES

- [1] M. Nishi, S. Takahashi, and T. Yoshida, "Indoor human detection systems using VHF-FM and UHF-TV broadcasting waves," Proc. of IEEE International Symposium on Personal Indoor and Mobile Radio Communication 2006 (PIMRC2006), Session TJ7.3, Sept. 2006.
- [2] S. Ikeda, H. Tsuji, and T. Ohtsuki, "Indoor Event Detection with Eigenvector Spanning Signal Subspace for Home or Office Security," IEICE Trans. Commun., vol.E92-B, no.7, pp.2406-2412, July 2009.
- [3] S. Ikeda, T. Ohtsuki, and H. Tsuji, "Signal-Subspace-Partition Event Filtering for Eigenvector-Based Security System Using Radio Waves," IEEE International Symposium on Personal Indoor and Mobile Radio Communications (PIMRC2009), Tokyo, Japan, Sep. 2009.
- [4] D. Gesbert et al., "From theory to practice: an overview of MIMO space-time coded wireless systems," IEEE Journal on Selected Areas in Commun., vol.21, no.3, pp.281-302, April, 2003.
- [5] K. Nishimori, Y.Koide, D. Kuwahara, N. Honma H. Yamada and H. Makino, "MIMO Sensor -Evaluation on Antenna Arrangement-, " Proc. of EuCAP2011, pp. 2924-2928, April, 2011.
- [6] J. W. Wallace and M. A. Jensen, "Time-Varying MIMO Channels: Measurement, Analysis, and Modeling," IEEE Trans. Antenna & Propagation, vol. 54, no.11, Nov. 2006.
- [7] IEEE 802.11n, <http://www.ieee802.org/11n/>
- [8] K. Nishimori, T. Mitsui, K. Ushiki and N. Takemura, "Channel estimation method using narrowband FSK signals for MIMO sensor," IEICE Trans. Commun. (in Japanese Edition), Vol.J-96B, No.9, 2013 (to be published).