

Compact Monopole Antenna with a 1-D EBG Radiator

S. H. Kim, K. H. Oh, D. J. Kim, J. I. Song and J. H. Jang*

Department of Information and Communications, Gwangju Institute of Science and Technology
1 Oryong-dong Buk-gu, Gwangju 500-712, South Korea, *jjang@gist.ac.kr

Abstract

Compact coplanar waveguide (CPW)-fed monopole antenna was designed by incorporating a one-dimensional electromagnetic bandgap (1-D EBG) structure in the radiator. The bandgap transition frequency of the 1-D EBG structure was designed to be a little bit higher than the antenna operating frequency. Slow wave characteristics of EBG cell below the bandgap region was utilized to reduce the size of the monopole antenna. The fabricated 1-D EBG monopole antenna exhibited the 58%-reduced size and comparable performance with large reference monopole antenna.

1. INTRODUCTION

Electromagnetic bandgap (EBG) structures are periodically arranged metallic or dielectric elements. EBG structures exhibit forbidden bandgap by suppressing surface-wave propagation [1-3]. Incorporation of EBG structures in substrates of microstrip antennas enhanced antenna gain and reduced backside radiation by suppressing surface wave propagation [2-4]. However, practical utilization of EBG structures in the area of microwave devices has been quite limited due to the large physical size until a mushroom-like EBG structure was introduced [5]. After this compact EBG structure was proposed, many types of EBG structures and their applications have been reported [6-7].

Another characteristic of periodic structures is slow wave effect near the bandgap region. This slow wave characteristic has been extensively utilized in photonics area and the periodic structures are called as photonic crystals. The same principle can be applied to microwave frequency. The effective dielectric constant of microwave materials increases at frequency near the bandgap region of periodic structures. Slow wave characteristics of periodic structures in microwave frequency have been utilized to reduce the size of the passive microwave devices [8-9]. Filters, ninety degree hybrids, phase shifters were designed by utilizing EBG structures. Antenna feeding network comprising EBG structure was also reported [10]. However, there has been no study on the usage of EBG structures on the radiating element on the antenna.

Monopole antennas have been found widespread applications in wireless communication systems. Especially, CPW-fed monopole antennas are intensively studied in recent years because of many attractive features such as wide

impedance bandwidth, omni-directional radiation pattern, and easy fabrication having a simplified configuration with a single metallic layer [11-12].

In this paper, slow wave effects of 1-D EBG cells with and without coplanar ground planes were analyzed. The designed 1-D EBG cell was inserted in the radiator of CPW-fed monopole antenna. To study the effect of the 1-D EBG cell in the radiator, the performances of antennas with and without EBG cells were compared. Antenna resonance frequency is dependent upon the location of 1-D EBG cell in the radiator. This effect was also analyzed and experimentally verified.

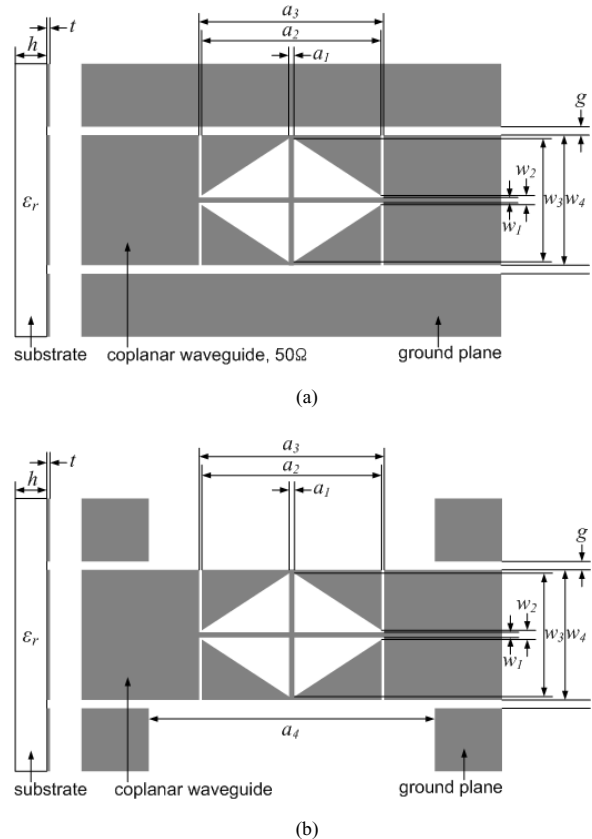

Fig. 1: Structures of 1-D EBG cells.
(a) 1-D CPW EBG cell. (b) Modified 1-D EBG cell

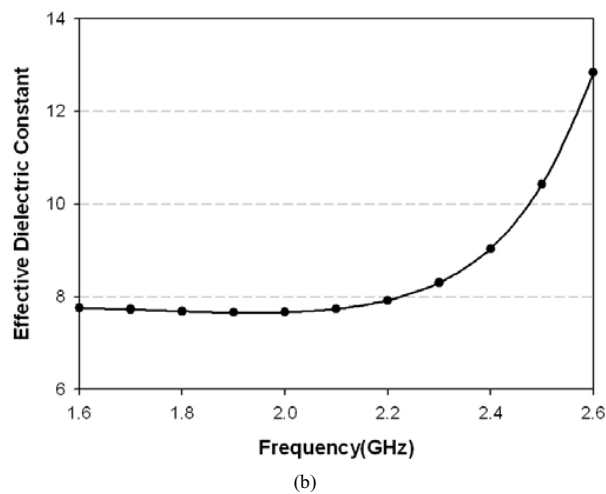
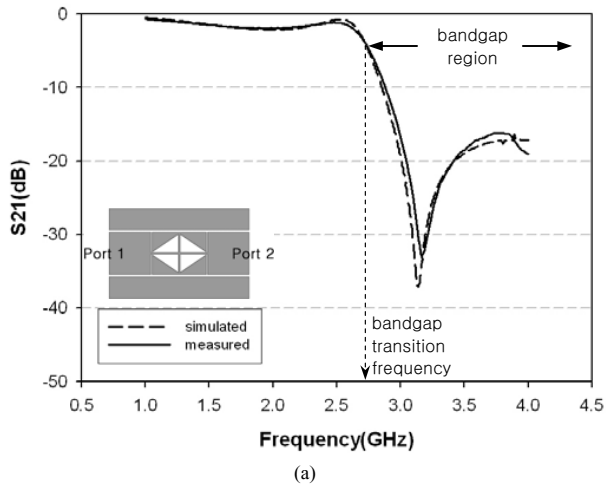

Fig. 2: Characteristics of the 1-D CPW EBG cell in Fig. 1. (a) Measured and simulated S_{21} 's. (b) Effective dielectric constant.

2. CHARACTERISTICS OF 1-D EBG CELL

One-dimensional CPW EBG cell embedded in the coplanar waveguides were firstly designed and fabricated as shown in Fig. 1(a). FR4 substrate with a dielectric constant (ϵ_r) of 4.4 and the height (h) of 1.6 mm was utilized. The parameters shown in Fig. 1(a) are as follows: $a_1 = 0.2$ mm, $a_2 = 8$ mm, $a_3 = 8.4$ mm, $w_1 = 0.2$ mm, $w_2 = 0.54$ mm, $w_3 = 5.8$ mm, $w_4 = 6.2$ mm, $g = 0.4$ mm, and $t = 0.018$ mm. Fig. 2(a) shows the measured (solid line) and simulated (dashed line) S_{21} 's. Bandgap transition of the 1-D CPW EBG cell takes place at 2.73 GHz when the transition frequency is defined to be at -3 dB frequency from the peak value of S_{21} . Effective dielectric constant was calculated by comparing frequency dependent phases of 1-D EBG embedded CPW line and conventional CPW line without 1-D EBG structures as shown in Fig. 2(b).

Effective dielectric constant increases as the frequency approaches to the bandgap transition frequency. As the effective dielectric constant goes higher, the lower the

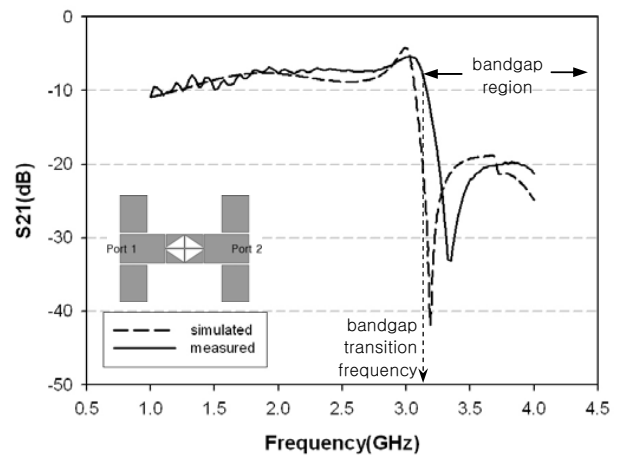

Fig. 3: Measured and simulated S_{21} 's of the modified 1-D EBG cell

propagation velocity of the transmitting wave becomes. It is called the slow wave effect [8], [13]. Miniaturized microwave devices by utilizing slow wave effect of EBG cells at near the bandgap transition frequency have been reported [9].

To insert an EBG cell in the radiator of monopole antenna, 1-D CPW EBG cell needs to be modified because the monopole antenna does not need ground planes at both sides of a radiator. As shown in the Fig. 1(b), the structure of the 1-D EBG cell was modified by removing the ground planes around the EBG cell. The cell parameters of the modified EBG cell in the Fig. 1(b) are the same with those in Fig 1(a) except a_4 that is 15 mm. The measured and simulated S_{21} 's of the modified transmission line are shown in Fig. 3. The bandgap transition frequency of the modified 1-D EBG cell changed to 3.14 GHz. It is due to the reduced parasitic capacitance between the EBG cell and the ground planes.

3. ANTENNA WITH 1-D EBG RADIATOR

The monopole antenna with a 1-D EBG cell is shown in Fig.

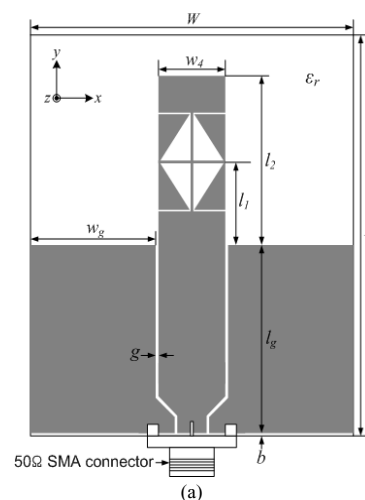

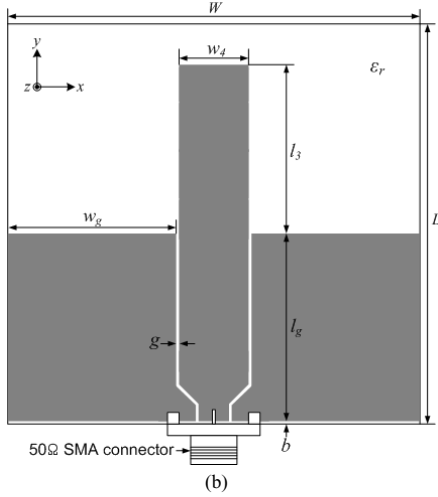

Fig. 4: Structures of the designed antennas. (a) Monopole antenna with a 1-D EBG cell (b) Reference conventional monopole antenna

4(a). For comparative study, a reference conventional CPW-fed monopole antenna was fabricated which is shown in Fig. 4(b).

Various antennas with and without 1-D EBG structures were designed to investigate the effect of 1-D EBG structure on the antenna performances. The resonant antenna frequency was varied by modifying the radiator length (l_x) of the reference and the proposed antenna. The length reduction ratio was defined to be $(l_3 - l_2) / l_3$ where l_2 and l_3 are the radiator lengths of the EBG antenna and reference antenna, respectively. As shown in the Table 1, the length reduction ratio increases when the operating frequency approaches to the bandgap transition frequency (3.14 GHz) of the 1-D EBG structure. However, antenna gain was reduced and the impedance matching was more difficult when the antenna operating frequency is too close to the bandgap transition frequency. There is a trade-off between antenna size and the antenna efficiency.

TABLE 1: LENGTH REDUCTION RATIO

Frequency (GHz)	Length of Radiators, l (mm)		Length Reduction Ratio (%)
	Reference antenna	EBG antenna	
2.14	30.2	19.5	35.43
2.23	28.0	17.5	37.50
2.33	26.0	15.5	40.38
2.45	24.0	13.5	43.75
2.56	22.3	11.5	48.43

A 1-D EBG antenna was designed for WLAN (wireless local area network) application. The resonant frequency of antenna was optimized in terms of impedance matching at 2.48GHz and impedance bandwidth by using a commercial simulator, Ansoft's HFSS. The optimized structural parameters for the antenna in Fig. 4(a) are as follows: $W = 30$ mm, $L = 40$ mm, $w_4 = 6.2$ mm, $l_2 = 15$ mm, $w_g = 11.5$ mm, $l_g = 19$ mm, $g = 0.4$ mm, and $b = 0.5$ mm. The parameters for

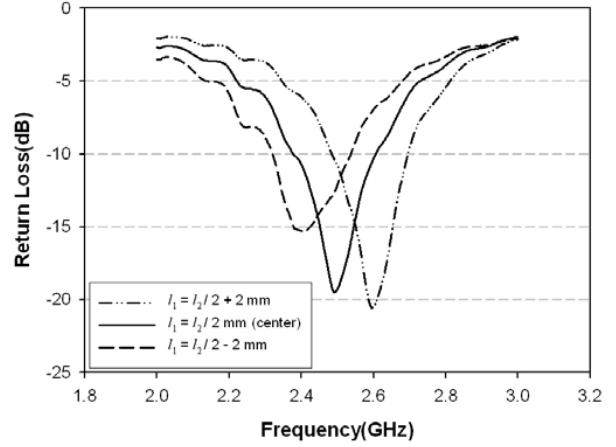

Fig. 5: Dependence of resonance frequency on the position of 1-D EBG cell in the radiator

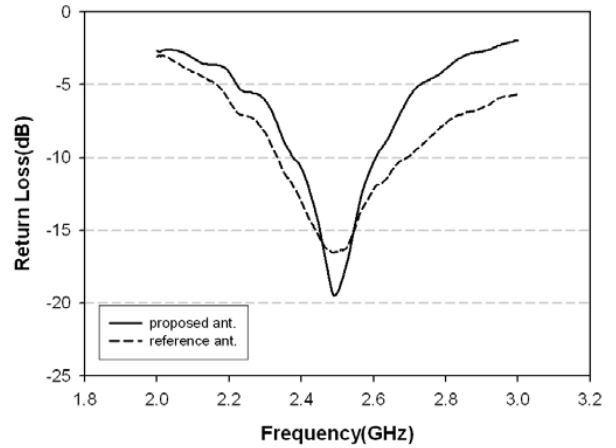

Fig. 6: Measured return loss of the reference and the proposed antenna.

the reference antenna in Fig. 4(b) are $W = 58$ mm, $L = 50$ mm, $w_4 = 6.2$ mm, $l_3 = 22$ mm, $w_g = 25.5$ mm, $l_g = 19$ mm, $g = 0.4$ mm, and $b = 0.5$ mm. The location of 1-D EBG cell was also an important parameter determining the performance of the antenna. Parametric study on the effects of the location of 1-D EBG structure in the antenna radiator was also carried out. The frequency responses of various antennas with different EBG locations were compared in Fig. 5. The resonant frequencies of antennas are dependent on relative position of the EBG cell. It is due to the effect of the parasitic capacitance between the EBG structures and CPW ground planes. When the EBG cell is close to the ground planes, the parasitic capacitance increases and the bandgap transition frequency reduces so that the stronger slow wave characteristics are observed. Consequently, the larger size reduction ratio can be achieved. However, impedance matching was found to be more difficult. On the other hand, for the antenna with EBG cell far from the ground planes, better return loss characteristic was obtained, but size

reduction ratio decreased. The optimum location of 1-D EBG structure on the radiator was found to be the center of the radiator to achieve large size reduction ratio and reasonable return loss (20 dB) together. The resonant frequency of the fabricated antennas was measured to be 2.489 GHz and the fractional bandwidth of the antenna with EBG radiator is 9.28% as shown in Fig. 6. The fabricated antenna covers the frequency band for IEEE 802.11 b/g WLAN which is between 2.4 GHz and 2.484 GHz. The total size of the proposed antenna was reduced by 58.62% in comparison with that of the reference antenna.

The radiation patterns of the EBG antenna was simulated and measured at the resonant frequency. The omni-directional radiation characteristics are similar to those of the reference monopole antenna as expected by the simulation study. The peak antenna gain 2.00 dBi was obtained at the resonant frequency.

4. CONCLUSION

A compact CPW-fed monopole antenna with 1-D EBG radiator was designed and characterized. The slow wave and band rejection characteristics of the 1-D EBG cell were studied. By incorporating the EBG cell in the radiator of the monopole antenna, compact antenna was designed and fabricated. The designed antenna satisfies the bandwidth specification of IEEE 802.11 b/g WLAN operation.

ACKNOWLEDGEMENT

This work was supported by the Center for Distributed Sensor Network at GIST

REFERENCES

- [1] E. R. Brown, C. D. Parker, and E. Yablonovitch, "Radiation properties of a planar antenna on a photonic-crystal substrate", *Journal of the Optical Society of America B: Optical Physics*, vol. 10, no 2, pp. 404-407, Feb 1993
- [2] R. Coccioli, W. R. Deal, T. Itoh, "Radiation characteristics of a patch antenna on a thin PBG substrate", *1998 IEEE Antennas and Propagation Society International Symposium*, pp. 656-659, Jun 1998.
- [3] K. Agi, M. Mojahedi, B. Minhas, E. Schamiloglu, K. J. Malloy, "The effects of an electromagnetic crystal substrate on a microstrip patch antenna", *IEEE Transactions on Antennas and Propagation*, vol. 50, no. 4, pp. 451-456. Apr 2002.
- [4] R. Gonzalo, P. de Maagt, and M. Sorolla, "Enhanced Patch-Antenna Performance by Suppressing Surface Waves Using Photonic-Bandgap Substrates", *IEEE Transactions on Microwave Theory and Techniques*, vol. 47, no. 11, pp. 2131-2138, Nov 1999.
- [5] D. Sievenpiper, Lijun Zhang, R. F. J. Broas, N. G. Alexopolous, and E. Yablonovitch, "High-Impedance Electromagnetic Surfaces with a Forbidden Frequency Band", *IEEE Transactions on Microwave Theory and Techniques*, vol. 47, no. 11, pp. 2059-2074, Nov 1999.
- [6] R. F. J. Broas, D. F. Sievenpiper, and E. Yablonovich, "An Application of High-Impedance Ground Planes to Phased Array Antennas", *IEEE Transactions on Antennas and Propagation*, vol. 53, no. 4, pp. 1377-1381, Apr 2005.
- [7] Li Yang, Mingyan Fan, Fanglu Chen, Jingzhao She, and Zhenghe Feng, "A novel compact electromagnetic-bandgap (EBG) structure and its applications for microwave circuits", *IEEE Transactions on Microwave Theory and Techniques*, vol. 53, no. 1, pp.183-190, Jan 2005.
- [8] Quan Xue, Kam Man Shum, and Chi Hou Chan, "Novel 1-D Microstrip PBG Cells", *IEEE Microwave and Guided Wave Letters*, vol. 10, no. 10, pp. 403-405, Oct 2000.
- [9] Kam Man Shum, Quan Xue, and Chi Hou Chan, "A Novel Microstrip Ring Hybrid Incorporating a PBG cell", *IEEE Microwave and Wireless Components Letters*, vol. 11, no. 6, pp. 258-260, Jun 2001.
- [10] Y. J. Sung and Y.-S. Kim, "An Improved Design of Microstrip Patch Antennas Using Photonic Bandgap Structure", *IEEE Transactions on Antennas and Propagation*, vol. 53, no. 5, pp. 1799-1804, May 2005.
- [11] Hornng-Dean Chen, and Hong-Twu Chen, "A CPW-Fed Dual-Frequency Monopole Antenna", *IEEE Transactions on Antennas and Propagation*, vol. 52, no. 4, pp. 978-982, Apr 2004.
- [12] H. S. Choi, S. H. Kim, K. H. Oh, and J. H. Jang, "Ultra-compact CPW-fed Monopole Antenna with Double Inverted-L Strips for Dual-band WLAN Applications", *2006 IEEE International Workshop Antenna Technology: Small Antennas and Novel Metamaterials*, pp. 72-75, Mar 2004.
- [13] J. Sor, Yongxi Qian, and T. Itoh, "A Novel Low-Loss Slow-Wave CPW Periodic Structure for Filter Applications", *2001 IEEE MTT-S International Microwave Symposium Digest*, pp.307-310, May 2001.