

# Integration of Antenna in IC Package for UWB Single-chip Radios

Sang-Hyuk Wi<sup>1</sup>, Yueping Zhang<sup>2</sup>, Mei Sun<sup>2</sup>, and Jong-Gwan Yook<sup>1</sup>

<sup>1</sup>Dept. of Electrical and Electronic Engineering, Yonsei University

134 Shinchondong, Seodaemoongu, Seoul, Korea, [wshnury@yonsei.ac.kr](mailto:wshnury@yonsei.ac.kr), [jgyook@yonsei.ac.kr](mailto:jgyook@yonsei.ac.kr)

<sup>2</sup>School of Electrical and Electronic Engineering, Nanyang Technological University  
Nanyang avenue, Singapore 639798, [sunm0001@ntu.edu.sg](mailto:sunm0001@ntu.edu.sg), [evpzhang@ntu.edu.sg](mailto:evpzhang@ntu.edu.sg)

## Abstract

*This paper presents a compact ultra-wideband (UWB) antenna integrated in a low-temperature cofired ceramic (LTCC) package. The overall dimension of the LTCC package is  $20 \times 20 \times 1.3 \text{ mm}^3$ , and has  $3.32 \times 2.76 \times 0.9 \text{ mm}^3$  internal space under the antenna ground plane for integration of a single-chip UWB transceiver die. The feeding network of the UWB antenna consists of feed via, signal trace of CPW, and bond wires which lead the signal from the output port of the bare chip to the UWB antenna. Moreover, the property of the designed antenna is calculated with  $30 \times 30 \times 0.5 \text{ mm}^3$  printed circuit board for practical applications and measurement. The bandwidth of the designed antenna is 4.96 GHz (3.04 GHz ~ 8 GHz). The radiation patterns at each resonant frequency are shown to be acceptable over a wide frequency range.*

## 1. INTRODUCTION

The Federal Communications Commission (FCC) released from 3.1 GHz to 10.6 GHz frequency band for ultra-wideband (UWB) application, where UWB transmission was defined as the occupied fractional bandwidth greater than 25% or larger than 1.5 GHz absolute bandwidth [1]. For the realization of the UWB radio systems, numerous studies have focused on the development of UWB antenna [2]-[6]. Planar monopole antennas are widely used due to their ultra wideband characteristic, near omni-directional radiation patterns, compact and simple geometry, and low cost. In [2], authors present planar monopole radiating elements, which are perpendicular to the ground plane, to achieve the UWB operation. Moreover, for the integration with planar systems, the printed monopole antennas are proposed and investigate [3]-[5]. In addition, to realize the wideband wireless device, UWB antennas are mounted on the wide system ground plane [6]-[8].

In recent years, the realization of highly integrated transceiver systems including system in package (SIP) is progressing rapidly. In [8]-[10], the authors propose package-level integrated antennas for the certain frequency band application. In addition, it is also interested that the integration of the UWB antenna for realization of the compact UWB radio transceiver package [11]-[13]. Especially, a

single package solution of UWB radio transceiver has been successfully demonstrated in complementary metal oxide semiconductor (CMOS) technology with a compact UWB antenna [12], [13]. However, the integration of the antenna is not easy task because the radiation properties, such as impedance bandwidth, efficiency, and radiation patterns, are directly related to the size and thickness of dielectric material, finite small ground planes and their position, and the feeding network. Moreover, integration of a UWB antenna must be considered all necessary interconnections between the antenna and integrated components. Namely, to create compact and fully integrated UWB transceivers, the UWB antenna has to be designed and optimized concurrently with the package topology and system ground plane.

In this paper, we propose a compact UWB antenna integrated in the low-temperature cofired ceramic (LTCC) package. The LTCC process is an attractive solution for the realization of three dimensional stacked-up UWB packages, and the high relative permittivity of LTCC material is advantageous regarding the overall circuit size. The proposed UWB antenna is designed with LTCC package geometry, single-chip transceiver die, interconnection, and system ground plane. The LTCC package is consisted of 3 layers. The top layer is a dielectric layer. The bottom layer and middle layer have an internal space for the integration of the bare chip, and the UWB antenna and ground plane are designed on the top of middle layer. Furthermore, for practical applications and measurement, we design conventional PCB under the LTCC package. The antenna ground plane on the second layer is directly connected to the system ground plane using multiple via holes. We describe the designed UWB antenna with the LTCC package and PCB in Section 2. The calculated results are presented in Section 3.

## 2. UWB ANTENNA AND PACKAGE CO-DESIGN

Fig. 1 shows three dimensional expanded view of the designed LTCC package and system ground plane. The Ag material is used for metallization where the Dupont 951 sheet (dielectric constant: 8.8, loss tangent: 0.002) is used for LTCC substrate. As mentioned in Section 1, the UWB antenna is integrated on the middle layer of LTCC package, and the package has an internal space for the integration of single-chip transceiver die.

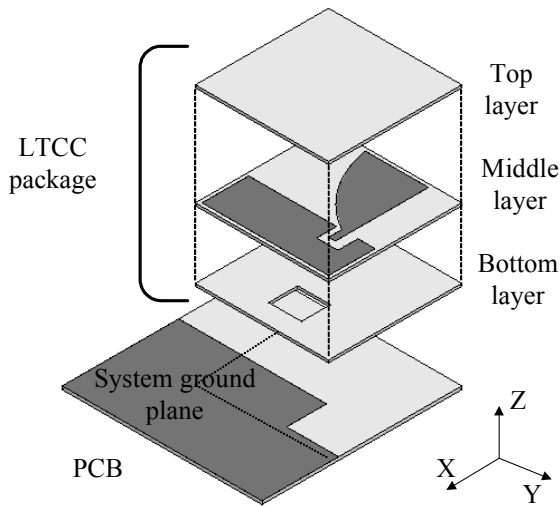
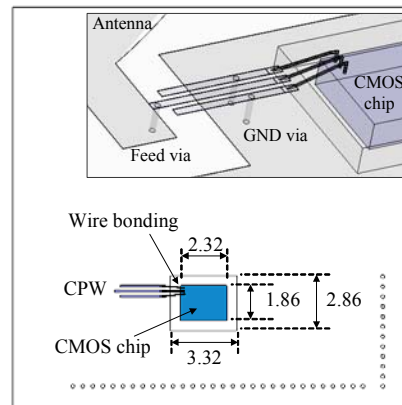
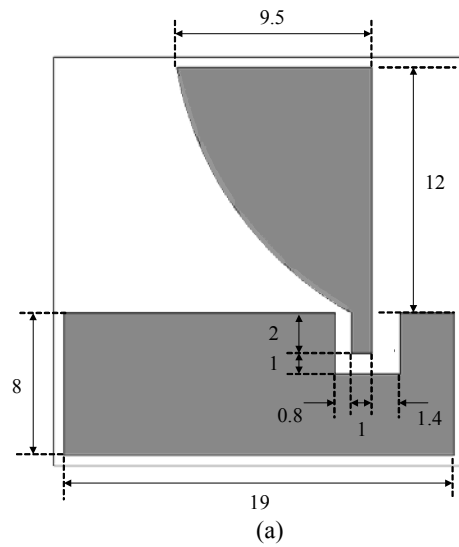

Fig. 1: Expanded view of the designed LTCC package and system ground plane.

The thicknesses of each dielectric layer used in this work are 0.4 mm (top), 0.5 mm (middle), and 0.4 mm (bottom). The overall dimension of LTCC package is  $20 \times 20 \times 1.3 \text{ mm}^3$ , and is mounted on top left corner of the PCB. The PCB is conventional FR4 board, and its total dimension is  $30 \times 30 \times 0.5 \text{ mm}^3$ . The system ground plane is designed for either sealing of the internal space or effective radiation of the UWB antenna.

Fig. 2(a), (b), and (c) describe detailed configuration and design parameters of the LTCC package. The top layer is dielectric layer which is necessary for fabrication process. This layer is also important for miniaturization and protection of the UWB antenna and antenna ground plane. As shown in Fig. 2(a), the UWB antenna and antenna ground plane are printed on the middle layer. The antenna has quarter-elliptical shape, and the length and width are 12 mm and 9.5 mm. Moreover, the horizontal gap (1 mm) and vertical gaps (0.8 mm and 1.4 mm) between the antenna and ground plane are important factors that govern the wideband impedance matching.

Fig. 2(b) shows the bottom view of the middle layer. This layer has an internal space of  $3.32 \times 2.86 \times 0.5 \text{ mm}^3$  for the integration of bare chip. In this work, the bare chip is assumed to be a silicon rectangular parallelepiped ( $2.32 \times 1.86 \times 0.5 \text{ mm}^3$ ) which has a  $50 \Omega$  matched output port and two ground pads on either side of the output port. In addition, it is also observed that there are bond wires and CPW line. The output port and ground pads of the bare chip are connected with the signal and ground line of CPW using bond wires with 0.05mm diameter. The width of each line of CPW is chosen to be 0.15 mm so that the CPW line has the characteristic impedance of nearly  $50 \Omega$ . Furthermore, the feed via links the CPW signal line to the UWB antenna. Therefore, we regard the bond wires, CPW line, and feed via as a feeding network. The CPW and feed via are made of Ag, while the bond wires are made of gold.



(b)

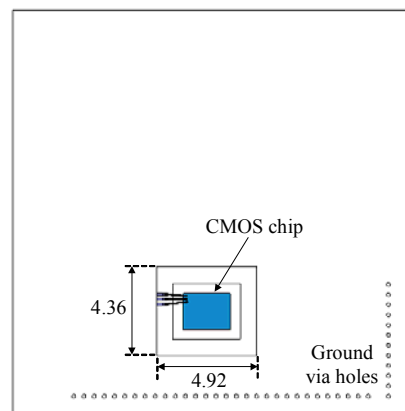

(c)

Fig. 2: Design parameters of the LTCC package; (a) top view of the middle layer, (b) bottom view of the middle layer with 3D view of feeding network, (c) bottom view of the LTCC package. (unit: mm)

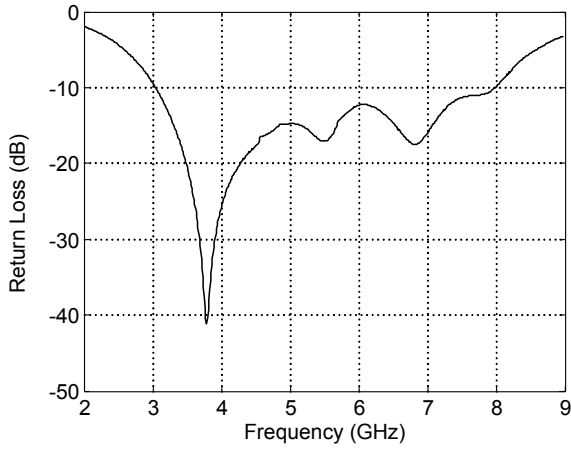

Fig. 3: Calculated return loss characteristic of the proposed UWB antenna.

Fig. 2(c) depicts the bottom view of the designed LTCC package. The bottom layer has an internal space of  $4.92 \times 4.36 \times 0.4 \text{ mm}^3$  for the integration process of the bare chip, such as adhesive bonding and wire bonding to the fabricated LTCC package. In addition, there are multiple via holes to connect the antenna ground plane placed on middle layer to system ground plane. The radius of ground via holes is 0.1 mm with 0.9 mm thickness.

### 3. CALCULATED RESULTS

The resonant properties of the UWB antenna integrated on LTCC package have been predicted and optimized using frequency domain three dimensional full wave electromagnetic field solver (Ansoft HFSS). The wholly integrated LTCC package is mounted on the PCB, and the excitation port is located under the output port of the bare chip. Namely, the UWB antenna is excited through the output port of the bare chip, bond wire, CPW line, and feed via. Fig. 3 shows the impedance characteristics of the designed UWB antenna. It is observed that the designed compact UWB antenna has multiple resonant frequencies of 3.88 GHz, 5.54 GHz, and 6.92 GHz and -10dB bandwidth covers from 3.04 GHz to 8 GHz (4.96 GHz) which is greater than 25% fractional bandwidth and is larger than 1.5 GHz absolute bandwidth described in [1].

The calculated XZ and YZ plane normalized radiation patterns at 3.88 GHz, 5.54 GHz, and 6.92 GHz are shown in Fig 4, Fig. 5, and Fig. 6, respectively. Solid lines are co-polarization and dashed lines are cross-polarization in each plane. In these figures, it can be seen that the radiation patterns are reasonable for indoor wireless communication. The relatively high cross-polarization levels are caused by current distribution of the UWB antenna and radiation from the feed network, such as gaps between antenna and antenna ground, CPW line, and bond wire. The calculated maximum gains at each resonant frequency are 1.8 dB, 2.8 dB, and 2.8 dB, respectively. The radiation efficiencies are more than 98% at three resonant frequencies.

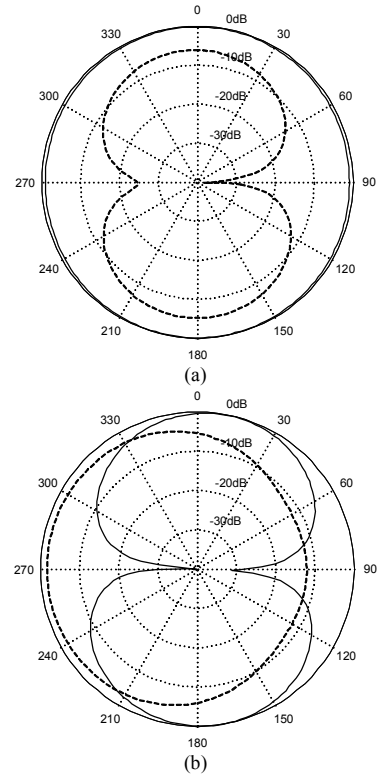

Fig. 4: Calculated radiation patterns at 3.88 GHz; (a) XZ plane, (b) YZ plane.

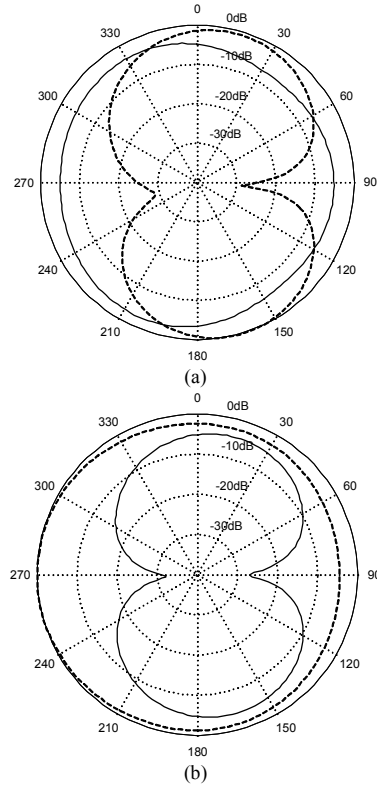

Fig. 5: Calculated radiation patterns at 5.54 GHz; (a) XZ plane, (b) YZ plane.

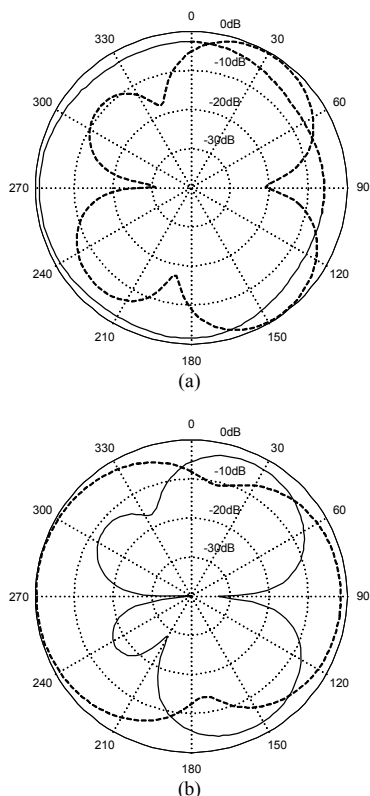

Fig. 6: Calculated radiation patterns at 6.92 GHz; (a) XZ plane, (b) YZ plane.

#### 4. CONCLUSION

This paper has focused on the integration of UWB antenna in IC package. The UWB antenna and antenna ground plane are located on the middle layer of the LTCC package, and the LTCC package has an internal space under the ground plane for the integration of single-chip transceiver die. The proposed UWB antenna is designed with conventional PCB and feeding network for the practical application. The feeding network consists of feed via, CPW line, and bond wires connected from the output port of the bare chip. The calculated results show that the designed antenna has a bandwidth of 4.96 GHz (3.04 GHz ~ 8 GHz) and reasonable radiation patterns at each resonant frequency for the indoor wireless environment. From these results we can conclude that the proposed UWB antenna and LTCC package are suitable for the realization of compact UWB transceiver.

#### REFERENCES

[1] Federal Communications Commission (FCC), Revision of Part 15 of the Commission's Rules Regarding Ultra-Wideband Transmission Systems First Report and Order, ET Docket 98-153, FCC02-48, Adopted Feb. 2002; Released Apr. 2002.

[2] M. J. Ammann and Zhi Ning Chen, "Wideband monopole antennas for multi-band wireless systems," *IEEE Antennas and Propagation Magazine*, Vol. 45, No. 2, pp. 146 ~ 150, April 2003

[3] Y. Chen, G. Y. Li, Y. P. Zhang, "An LTCC planar ultra-wideband antenna," *Microwave and Optical Technology Letters*, Vol. 42, No. 3, pp. 220-222, August 2004.

[4] Y. Chen, Y. P. Zhang, "Integration of ultra-wideband slot antenna on LTCC substrate," *IEE Electronics Letters*, Vol. 40, No. 11, pp. 645-646, May 2004.

[5] Albert Chee W. Lu, Kai M. Chua, and M. Sun, "LTCC-based compact wideband antenna," *Microwave and Optical Technology Letters*, Vol 48, No. 6, pp. 608 ~ 609, December 2005.

[6] Wang-Sang Lee, Ki-Jin Kim, Dong-Zo Kim and Jong-Won Yu, "Compact frequency-notched wideband planar monopole antenna with a L-shape ground plane," *Microwave and Optical Technology Letters*, Vol 46, No. 6, pp. 563 ~ 566, December 2005.

[8] Jihak Jung, Yeonsik Yu, and Jaehoon Choi, "A small wideband planar monopole antenna for mobile wireless devices," *Microwave and Optical Technology Letters*, Vol 48, No. 4, pp. 836 ~ 840, April 2006.

[8] Y. P. Zhang, "Finite-difference time-domain analysis of integrated ceramic ball grid array package antenna for highly integrated wireless transceivers," *IEEE Transactions on Antennas and Propagation*, Vol. 52, No. 2, pp. 435 ~ 442, February 2004.

[9] Y. P. Zhang, "Integrated circuit ceramic ball grid array package antenna," *IEEE Transactions on Antennas and Propagation*, Vol. 52, No. 10, pp. 2538 ~ 2544, October 2004.

[10] Sang-Hyuk Wi, Young-Bin Sun, In-Sang Song, Sung-Hoon Choa, Il-Suek Koh, Yong-Shik Lee, and Jong-Gwan Yook, "Package-Level Integrated Antennas Based on LTCC Technology," *IEEE Transactions on Antenna and Propagations*, will be published in August 2006.

[11] Y. Chen, Y. P. Zhang, "A planar antenna in LTCC for single-package UWB radio," *IEEE Transactions on Antennas and Propagation*, Vol. 53, No. 9, pp. 3089-3093, September 2005.

[12] Junwoo Lee, Young-Jin Park, Myunghoi Kim, Changwook Yoon, Joungho Kim, and Kwan-Ho Kim, "System-on-package ultra-wideband transmitter using CMOS impulse generator," *IEEE Transactions on Microwave Theory and Techniques*, Vol. 54, No. 4, pp. 1668 ~ 1684, April 2006.

[13] Yuanjin Zheng, Yueping Zhang, and Yan Tong, "A novel wireless interconnect technology using impulse radio for interchip communications," *IEEE Transactions on Microwave Theory and Techniques*, Vol. 54, Issue 4, Part 2, pp. 1912 ~ 1920, June 2006.