

AN OPTIMIZED TRANSITION FROM SINGLE- TO MULTI-MODE RECTANGULAR WAVEGUIDES

Yuri TIKHOV, Jeong-Phill KIM, Kong-Mahn PARK, and Young-Ki CHO*

LG Precision Co., Ltd., 148-1, Mabuk-Ri, Gusung-Myun, Yongin-Shi,

Kyunggi-do 449-910, Suwon P.O. Box 188, Korea

* Department of Electronics, Kyungpook National University, Taegu, 702-701, Korea

E-mail tikhov@lgp.co.kr

Abstract – We consider a novel transition for broadband efficient transmission of the fundamental mode and suppression of the higher order parasitic modes in the multi-mode rectangular waveguide with an increased dimension of the narrow wall. The CAD procedure utilizes rigorous EM simulation algorithm and optimization. The designed compact Ka-band transition demonstrates excellent electrical capability and stability with respect to fabrication tolerance variations.

Introduction - At millimeter wavelengths, the problem of reducing the dissipation losses in the transmission lines becomes critical for various applications. Due to its low-loss characteristics, the rectangular waveguides with a significantly increased dimension of the narrow wall are of promising value for this purpose [1]. The indicated waveguides become multi-mode but operate on the fundamental TE_{10} mode. For instance, insertion losses of uniform WR-28 waveguide 7.112×3.556 mm are about 1 dB/m, while the attenuation of the waveguide with 7.112×16 -mm cross section is about 0.3 dB/m for TE_{10} mode. Main advantage of a multi-mode rectangular waveguide is that this structure allows smooth H -plane bending [2]. As the result, in-phase H -plane systems of mm-wave power distribution can be implemented with excellent performances. Such systems find important application in the array antenna [3].

Realization of the multi-mode waveguides requires excitation of the fundamental TE_{10} mode as well as suppression of the parasitic waves. To this end, specially constructed transitions are needed. There are two common ways to construct a transition. One is a smooth transition and the other is a stepped one. Here we consider stepped type of transition for optimization by use of an EM CAD procedure. The reason for this choice is its compactness.

Statement of Problem – The desired transition is the two-port device, which excites fundamental TE_{10} mode and suppresses parasitic modes in the multi-mode port for the given TE_{10} incident in the single-mode port. Typically the “narrow” wall “ b ” size is required to be increased in about 5 times as that of the single-mode port, while the dimension “ a ” is normally within limits from half of wavelength to one wavelength. So together with the fundamental mode, the propagating waves in such a waveguide port are the following modes: TE_{11} , TM_{11} , TE_{12} , TM_{12} , TE_{13} , TM_{13} , TE_{01} , TE_{02} , and TE_{03} . However, TE_{11} , TM_{11} , TE_{13} , TM_{13} , TE_{01} , TE_{02} , and TE_{03} parasitic modes can be excited in the symmetrical transition only in the case of distortion of the symmetry in the process of fabrication. So the parameters to be minimized are power reflected from the single-mode waveguide input and levels of excitation of parasitic modes TE_{12} and TM_{12} in the multi-mode waveguide. The transmission of fundamental TE_{10} mode to multi-mode port should be maximized. To allow more compact transition design, an overall length of the transition can be included into the set of parameters to be minimized.

Simulation Approach - A rectangular waveguide stepped transition from width a_0 and height b_0 to be width a_n and height b_n is shown in Fig. 1. This transition structure consists of discontinuities of the step waveguide junctions and uniform waveguide segments. Although the desirable ideal transition is of symmetrical shape with respect to longitudinal axis, the more general unsymmetrical case has

been chosen as a model in order to simulate the unsymmetry effects possibly occurring in the fabrication process. In this connection the unsymmetrical double-plane waveguide junctions were used in the model structure. The generic case of waveguide junction is shown in Fig. 2a and b, where the correlation between geometrical parameters is arbitrary and parameters c and d can be positive as well as negative.

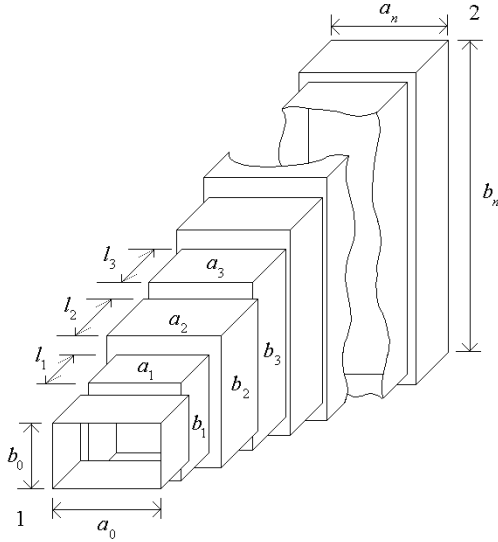

Fig. 1. A generic configuration of transition.

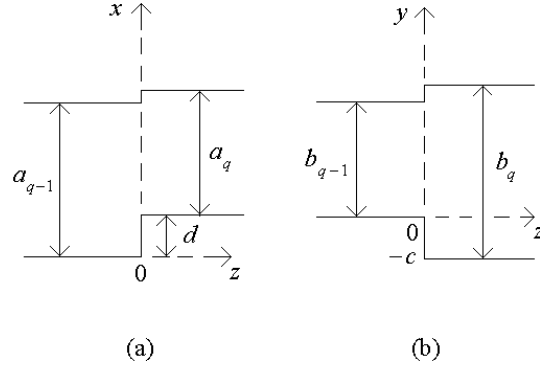

Fig. 2. Unsymmetrical double-plane waveguide elementary junction. (a) Longitudinal $x0z$ – sectional view (b) $y0z$ – sectional view.

The analysis takes into account higher order mode interaction of the structure's discontinuities by use of generalized scattering matrix technique. Thus, the main simulation problem reduces to a determination of the generalized multi-mode descriptor for the junction. An EM basis in the form of a system of LSE and LSM eigenmodes has been used for the solution of the junction problem. Note that the LSE_{m_0} (LSM_{0n}) modes are equal to TE_{m_0} (TE_{0n}) ones respectively. The linear combination of each pair of arbitrary LSE_{mn} and LSM_{mn} modes can be represented as a pair of TE_{mn} and TM_{mn} modes.

The generalized scattering matrix of the junction was obtained by solving 3D vector diffraction problems formulated by use of the following principle - “each of the eigenmodes excites the entire spectrum of eigenmodes”. These problems were rearranged to the system of integral equations for the unknown transverse electric field $E_{x,y}(x, y)$ in the aperture of the junction. The integral equations are solved by Galerkin's method.

A key point of suggested theory is special choice of the basis functions for the Galerkin's procedure. Namely, these basis functions are weighted Gegenbauer polynomials. Such choice of basis functions adequately describes field behavior not only very near the structure's metal edges, but also within middle distances [4]. In essence, the utilization of prior explicit information about field behavior near the discontinuities guarantees rapid convergence, high accuracy, and consequently, also high efficiency for the entire simulation algorithm. The efficiency is of critical value here because of iterative essence of the optimization procedure to be applied.

Objective Function - Consider the case that the LSE_{10} mode is incident in the waveguide port 1 upon the plane of the first junction (Fig. 1). If the amplitude of the incident is normalized to be unity, then the amplitude of the reflected LSE_{10} mode in waveguide port 1 is $S_{11}^{LSE_{10}}$, the amplitude of the transmitted LSE_{10} in waveguide port 2 is $S_{21}^{LSE_{10}}$, and the amplitudes of the excited LSE_{12} and

LSM_{12} modes in port 2 are $S_{21}^{LSE_{12}}$ and $S_{21}^{LSM_{12}}$ respectively. Unlike the conventional transformer design approach [5,6], the objective function here explicitly includes the terms corresponding to the higher order mode excitation. For the ideal symmetrical case it is sufficient to consider the objective function to be minimized as follows:

$$U(\Phi) = W_1 \sum_{i=1}^I |S_{11}^{LSE_{10}}(\Phi, f_i)|^2 + W_2 \sum_{i=1}^I |S_{21}^{LSE_{10}}(\Phi, f_i)|^{-2} + W_3 \sum_{i=1}^I |S_{21}^{LSE_{12}}(\Phi, f_i)|^2 + W_4 \sum_{i=1}^I |S_{21}^{LSM_{12}}(\Phi, f_i)|^2 + W_5 \sum_{q=1}^{n-1} l_q \quad (1)$$

Where f_i are frequency sample points, Φ is the geometrical parameter vector, W_1, W_2, W_3, W_4, W_5 are weighting factors, and $S_{11}^{LSE_{10}}, S_{21}^{LSE_{10}}, S_{21}^{LSE_{12}}, S_{21}^{LSM_{12}}$ are scattering parameters. The number of equidistant frequency sample points I was chosen to be equal to 21 here. The objective function (1) is minimized with respect to the parameter vector $\Phi = (a_1, a_2, \dots, a_{n-1}, b_1, b_2, \dots, b_{n-1}, l_1, l_2, \dots, l_{n-1})$. Where $a_q, b_q,$ and l_q are, respectively, the width, the height, and length of the transition section

Transition Design Example - The designed Ka-band transition begins with standard waveguide WR-28 (7.112×3.556 mm) and ends with converted WR-62 (7.899×15.779 mm). In order to expedite experimental back-to-back test fixture, standard WR-62 tube has been chosen as a multi-mode waveguide. Such choice has allowed the increase of the narrow wall dimension in about 5 times as much, while the increase of the broad wall size has been within 10%. The transition is contemplated to operate within the frequency band from 27 GHz up to 37 GHz.

The five-sectional transition has been optimized. The dimensions of optimized transition are given in Table 1. It should be noted that the topology of the transition structure has a nonmonotonic variation of the a_q dimensions along the longitudinal axis as shown in Fig.1. Such shape of the transition provides the successful suppression of the parasitic modes. The physical fact of the matter is that the currents in the waveguide walls for the parasitic LSE_{12} and LSM_{12} modes have the different distributions as compared with fundamental one.

Table 1: Dimensions of optimized transition. All units are in mm.

q	0	1	2	3	4	5	6
a_q	7.112	6.63	7.75	6.42	6.57	7.29	7.899
b_q	3.556	4.91	9.23	11.93	13.69	14.93	15.779
l_q	-	2.11	3.25	4.06	4.59	9.98	-

The levels of excited parasitic modes as well as reflection coefficient of the fundamental mode for the optimized transition are shown in Fig. 3. The maximum value of $S_{11}^{LSE_{10}}$ is -25 dB, and insertion losses $S_{21}^{LSE_{10}}$ amount to no more than 0.1 dB.

The probable distortion of the symmetry in the process of fabrication has been also simulated. In order to perform the sensitivity analysis some offsets were superinduced into the model of optimized transition. The effect of the ± 0.05 -mm offsets in the x -direction was evaluated first. In this case the corresponding level of parasitic LSM_{02} mode doesn't exceed -40dB (hereinafter the worst case). Note that LSM_{01} and LSM_{03} modes are not excited in the case of x -distortion of the symmetry because the LSE_{10} is incident. The effect of the ± 0.05 -mm offsets in the y -direction was evaluated second. The corresponding maximum levels of the excited $LSE_{11}, LSM_{11}, LSE_{13}, LSM_{13}$ modes are -26dB, -42dB, -36dB, and -50dB, respectively. The data corresponding to the distortion of symmetry in both directions together are presented in Fig. 4. All eigenmodes above cutoff are excited

as expected. The attenuation of LSE_{12} and LSM_{12} modes is not shown in Fig.4 and, however, has been observed to amounts to better than -18 dB. For the worst case the maximum value of $S_{11}^{LSE_{10}}$ has been observed to be still about -25 dB.

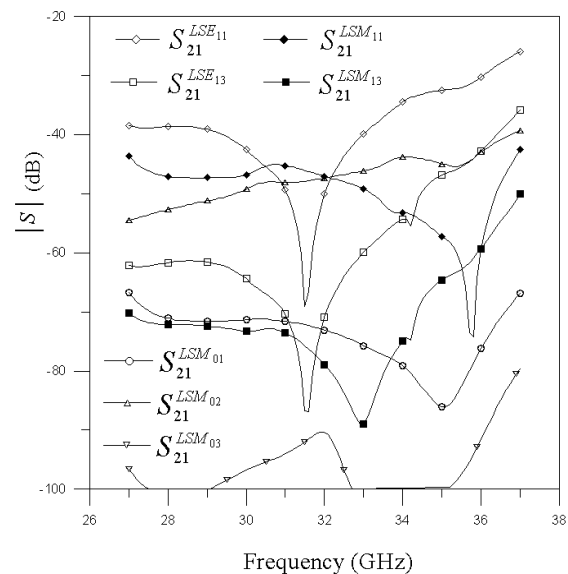
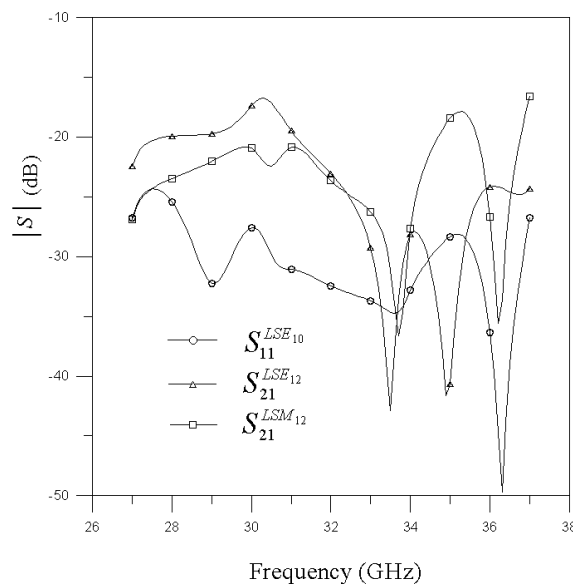

Fig. 3. Scattering parameters for optimized transition. Fig. 4. Levels of the parasitic modes excited because of the distortion of symmetry.

An overall length of the transition is about 24 mm. Such length looks very competitive compared with the smooth structure [2] with similar electrical performances and size of 50 mm.

Conclusion - An EM theory based CAD procedure has been proposed and demonstrated for the transition from single-mode to multi-mode rectangular waveguides. The rigorous EM method outlined provides high efficiency of the simulation algorithm and guarantees veracity of numerical results. Proposed compact optimized structure of the Ka-band transition provides excellent transmission of the fundamental mode and effective suppression of the parasitic higher order modes. An extensive tolerance study was also undertaken. It was found that transition design is stable with respect to typical fabrication variations. The aforementioned features provide a useful transition that can be implemented in mm-wave power distribution systems.

References

- [1] Microwave power engineering. Edited by C. Okress, New York and London, Academic Press, vol. 1., 1968.
- [2] B.Kh. Gol'berg, and Yu.V. Pashinov, "Multimode rectangular waveguides for in-phase power distribution in mm-wave band phased array antennas," The XXVIII Int'l Conference On Antenna Theory and Technology, Moscow, Proceedings, pp. 504-506, 1998.
- [3] A.A. Tolkachev, V.V. Denisenko, A.V. Shishlov, and A.G. Shubov, "High gain and high power antenna system for advanced multifunction millimeter wave radars," CIE Int'l Conference of Radar, Beijing, Proceedings, pp. 499-502, 1996.
- [4] Yu. Tikhov, J.H. Ko, and Y.K. Cho, "Field theory based design and comparison of two kinds of quasi-planar bandpass filters," IEE Proceedings Microwave, Antennas and Propagation, vol. 145, No 6, pp. 441-448, 1998.
- [5] F. Arndt, U. Tucholke, and T. Wriedt, "Computer-optimized multisection transformers between rectangular waveguides of adjacent frequency bands," IEEE Trans. Microwave Theory and Techniques, vol. 32, No 11, pp. 1479-1484, Nov. 1984.
- [6] Yu. Tikhov, G.P. Sinyavsky, Yu.M. Sinelnikov, "Electrodynamic modeling and optimization of stepped transformers between rectangular waveguides," Journal of Communications Technology and Electronics, vol. 40, No. 2, pp. 234-239, 1995.