

EXPERIMENTAL STUDY ON ARRAY BEAM FORMING UTILIZING THE GUARD INTERVAL IN OFDM

Satoshi Hori[†], Nobuyoshi Kikuma^{††}, Tomohisa Wada[‡], Mitoshi Fujimoto^{‡‡}

[†] Antenna Engineering Department, Kojima Press Industry Co., Ltd.

15 Hirokuden, Ukigai, Miyoshi-cho, Nishikamo-gun, Aichi, 470-0207 Japan

hori@kojima-tns.co.jp

^{††} Department of Computer Science and Engineering, Nagoya Institute of Technology

[‡] Department of Information Engineering, University of the Ryukyus

^{‡‡} Department of Information Science, Faculty of Engineering, University of Fukui

1. Introduction

Terrestrial digital TV broadcasting in Japan (ISDB-T) has already been initiated in three major metropolitan areas in 2003, and nationwide broadcasting will start in 2006. In ISDB-T, Orthogonal Frequency Division Multiplexing (OFDM), which has many features such as relatively high spectral efficiency and modulation that can be performed by FFT, is adopted as a modulation scheme. In order to combat the delay spread of the channel, a guard interval (GI) is added at the head of each effective symbol. Hence, it is known that the communication performance is superior especially to that of a single carrier in a multipath environment.

However, in actual ISDB-T based on OFDM modulation, there are some difficulties in both fixed and mobile receptions. For example, since a high-gain antenna is set at high location in most fixed receptions, multi-path waves with long delay from remote transmitting stations are also received when the Single Frequency Network (SFN) is introduced. Consequently, inter-carrier interference occurs and the reception quality degrades awfully. Even with signals that are delayed within the GI, the reception quality also deteriorates if the value of DUR (Desired-to-Undesired signal power Ratio) decreases.

Array Beam Forming (ABF), on the other hand, is well known as the strategy to reduce the signal fluctuations caused by multipath waves. Based on this concept, in this paper, we propose an ABF system utilizing the GI in OFDM and show performances of its prototype through experiments.

2. Proposed Array Beam Forming for OFDM

2.1 Configuration of the system [1]

Figure 1 shows the configuration of the OFDM modulated signals. The signal consists of the GI (T_g) and the effective symbol interval (T_e). For the GI, the same waveform as the tail T_g of the effective symbol duration is added to ahead of the effective

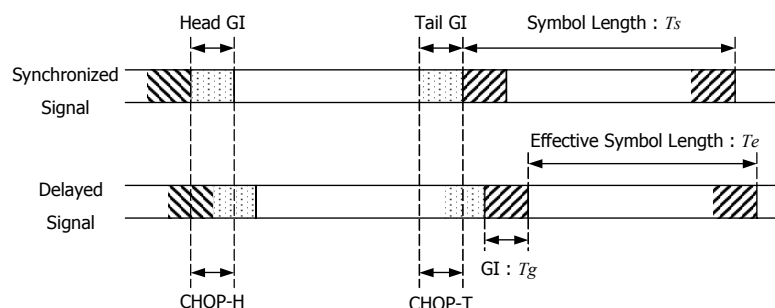

Fig.1: OFDM modulated signals.

symbol. For convenience in this paper, the original GI is referred to as “the Head GI” and also the tail T_g duration of the effective symbol is referred to as “the Tail GI”.

Figure 2 shows the configuration of the proposed system consisting of a K -element array. The base band signals from the antenna elements, $x'_k(t)$ ($k = 1, 2, \dots, K$), are multiplied with weight coefficients, w_k , and combined into the output signal, $y'(t)$. In Fig. 2, with the synchronized signal as the basis, CHOP-H extracts length of the GI (duration of T_g) from the base band signal as $x_k(t)$. Correspondingly CHOP-T extracts the length of the GI from the combined output as $y_t(t)$. The notations for the received signals are defined as follows. The vector representations for the base band signals and the weights are defined as

$$\mathbf{X}'(t) = [x'_1(t), x'_2(t), \dots, x'_K(t)]^T \quad \mathbf{X}(t) = [x_1(t), x_2(t), \dots, x_K(t)]^T \quad (1)$$

$$\mathbf{W} = [w_1, w_2, \dots, w_K]^T \quad (2)$$

The combined output $y'(t)$ of the array is given by

$$y'(t) = \mathbf{W}^H \mathbf{X}'(t) \quad (3)$$

Here, the superscripts T and H represent the transpose and the conjugate transpose, respectively.

2.2 Array beam forming algorithm for OFDM signals

ABF algorithm requires an input signal vector and a reference signal. The extracted signal vector $\mathbf{X}(t)$ from CHOP-H is utilized as the input signal vector and the extracted signal $y_t(t)$ from CHOP-T is utilized as the reference signal in the proposed system. That is, the weight coefficient vector of the proposed ABF (\mathbf{W}_{ABF}) is expressed as follows,

$$\mathbf{W}_{ABF} = E[\mathbf{X}(t) y_t^*(t)] \quad (4)$$

where $E[\cdot]$ denotes the expected value calculation.

In the conventional Maximal Ratio Combining (MRC), there is possibility that undesired strong interferences are captured [2]. On the other hand, it is expected that undesired signals such as non-OFDM signal or interfering asynchronous OFDM signal cannot be captured in the ABF.

3. Experimental Study

3.1 Specification of the prototype and experimental setup

Table 1 and Fig.3 show the specification and the photograph of the prototype, respectively. We conducted the experiments to analyze the basic performance of the proposed system. Table 2 lists the conditions of the measurements and Fig.4 shows the block diagram of measurement system. The broadside direction of the array was set to 0 degrees and CNR with respect to the 1st signal was set to 30dB. For comparison, 1 element antenna and MRC utilizing the cross-correlation coefficients between $\mathbf{X}(t)$ and $y_h(t)$, which was extracted by CHOP-H, are also evaluated (see Fig. 2) [2].

Table 1: Specification of the prototype.

| | | | |
|------------|---------------------------------|-----------------------------------|--------|
| ABF MRC | ADC | Channels | 4 |
| | | Resolution | 10bits |
| | | Sampling rate | 32MHz |
| FPGA | Xilinx Vertex-II Pro VP70, VP20 | | |
| | CPU | PowerPC405 260MHz | |
| OFDM | FPGA | Xilinx Vertex-II V4000 × 2, V3000 | |

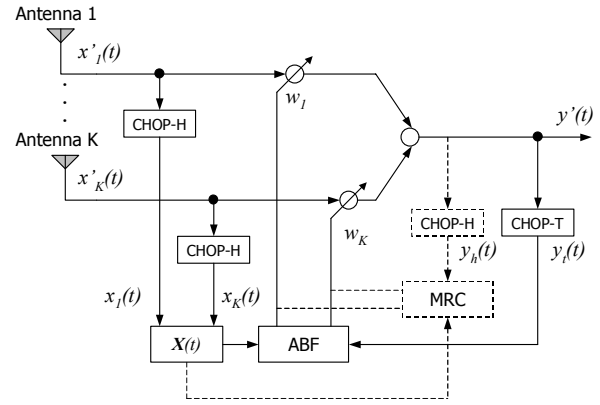

Fig.2: Block diagram of proposed system.

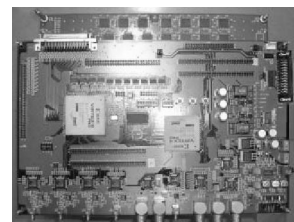

Fig.3: Photograph of the prototype.

Table 2: Condition of the measurements.

| | | |
|----------|---|-------------------|
| Antennas | 4-element linear array with equal spacing | |
| | Antenna element | Isotropic element |
| | Element interval | 0.2662m |
| ISDB-T | DTV28CH Mode3 | |
| | Frequency | 563.143MHz |
| | No. of carriers | 5617 |
| | Effective symbol length | 1.008ms |
| | GI length | 126 μ s (1/8) |
| | Modulation scheme | 64QAM |

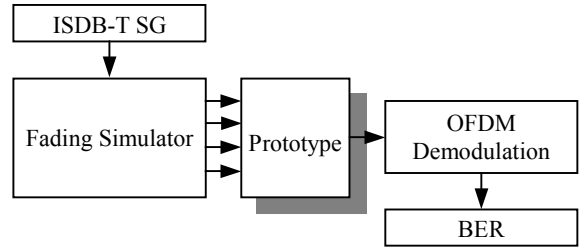

Fig.4: Block diagram of the measurement system.

3.2 2-arrival wave environment

First, we evaluated the BER performances in a 2-arrival wave environment. Table 3 lists the details on the radio environment. Figures 5 and 6 show the BER performances when the delay times are 21 μ s and 147 μ s, respectively. We can find from the figures that ABF is superior to MRC as the value of DUR decreases. Figures 7 and 8 show the beam patterns that were calculated from the weight coefficients when the delay time was 21 μ s. In case of MRC, as the value of DUR decreases, the gain for the 2nd wave increases. Because of this, the BER performance of MRC is worse than that of the ABF.

Table 3: Radio Environment (1).

| | Arrival angle [deg] | Delay time [μ s] | Power [dB] |
|----------------------|---------------------|--|------------------------------|
| 1 st wave | -30 | 0 | 0 |
| 2 nd wave | 15 | 21 (1/6 \cdot T _g), 63 (3/6 \cdot T _g), 105 (5/6 \cdot T _g), 147 (7/6 \cdot T _g) | 0, -1, -3, -5, -10, -15, -20 |

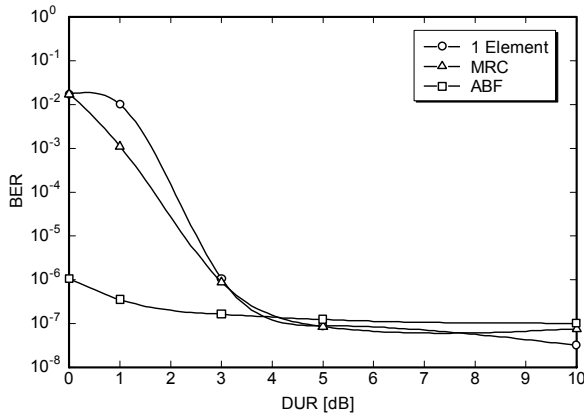

Fig.5: BER characteristics in radio environment (1) (Delay = 21 μ s).

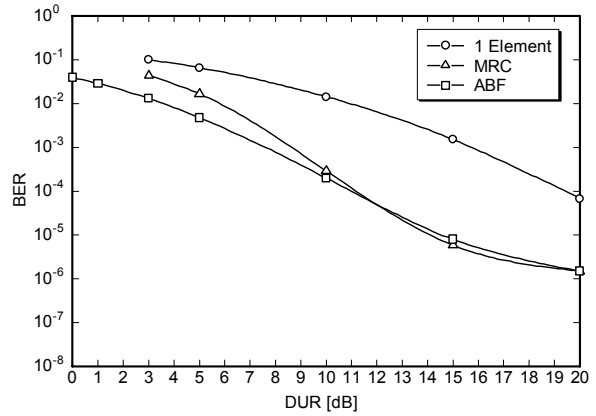

Fig.6: BER characteristics in radio environment (1) (Delay = 147 μ s).

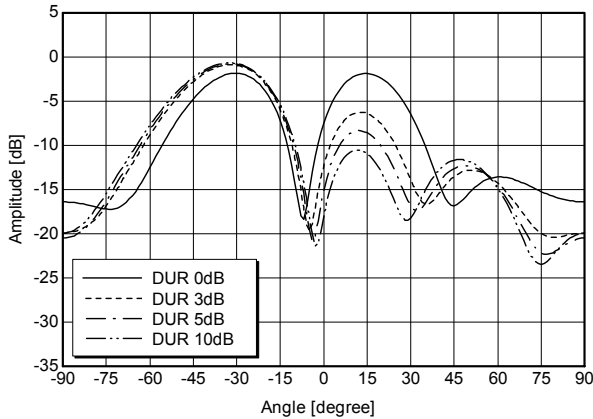

Fig.7: Beam patterns of MRC in radio environment (1) (Delay = 21 μ s).

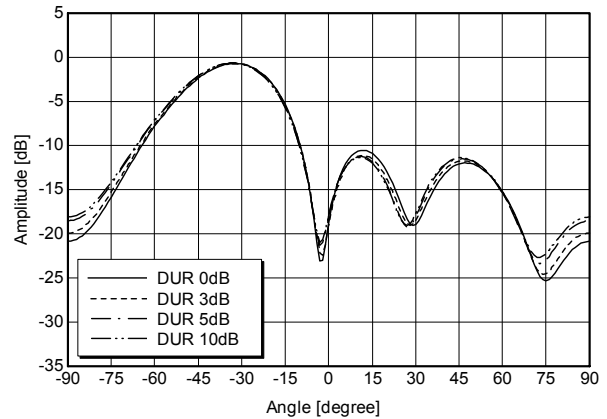

Fig.8: Beam patterns of ABF in radio environment (1) (Delay = 21 μ s).

3.4 4-arrival wave environment

Next, we examined the performance in a 4-arrival wave environment. Tables 4 and 5 give details on the radio environments. Tables 6 and 7 list BER performances, and Figures 9 and 10 show the beam patterns in the radio environments (2) and (3), respectively. From the results, when the power of the delayed signals decreases, the beam patterns of MRC come to almost the same as the ABF. Notably, the beam patterns of MRC in the case1 are greatly different from the others. In other words, MRC features trying to capture all arrival waves when the value of DUR is much small.

Table 4: Radio Environment (2).

| | Arrival angle [deg] | Delay time [μs] ($*T_g$) | Power [dB] | |
|----------------------|---------------------|---|------------|-------|
| | | | Case1 | Case2 |
| 1 st wave | -30 | 0 | 0 | 0 |
| 2 nd wave | 15 | 47.25 (3/8) | 0 | -3 |
| 3 rd wave | -75 | 94.50 (6/8) | 0 | -6 |
| 4 th wave | 60 | 141.75 (9/8) | 0 | -9 |

Table 5: Radio Environment (3).

| | Arrival angle [deg] | Delay time [μs] ($*T_g$) | Power [dB] | |
|----------------------|---------------------|---|------------|-------|
| | | | Case1 | Case2 |
| 1 st wave | -45 | 0 | 0 | 0 |
| 2 nd wave | 15 | 47.25 (3/8) | 0 | -3 |
| 3 rd wave | -30 | 94.50 (6/8) | 0 | -6 |
| 4 th wave | -60 | 141.75 (9/8) | 0 | -9 |

Table 6: BER in Radio Environment (2).

| | 1 Element | MRC | ABF |
|-------|-----------|---------|---------|
| Case1 | - | - | 2.42E-2 |
| Case2 | 3.89E-2 | 1.71E-3 | 1.79E-4 |

Table 7: BER in Radio Environment (3).

| | 1 Element | MRC | ABF |
|-------|-----------|---------|---------|
| Case1 | - | - | 4.84E-2 |
| Case2 | 3.69E-2 | 5.16E-3 | 7.88E-4 |

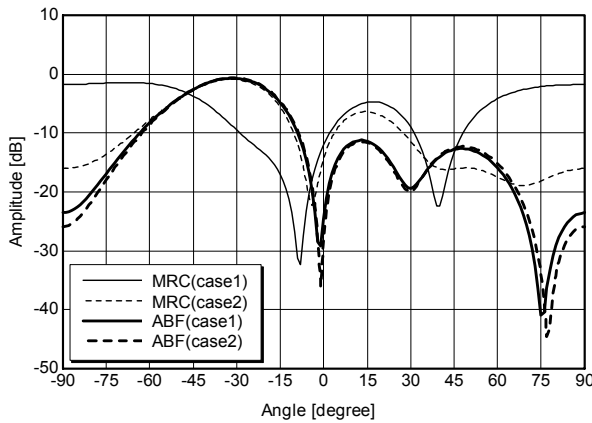

Fig.9: Beam patterns in radio environment (2).

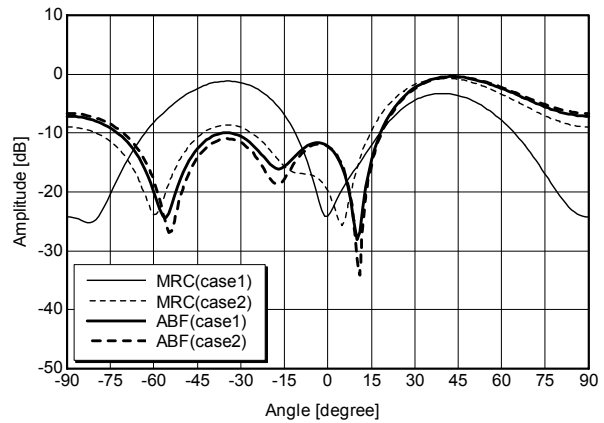

Fig.10: Beam patterns in radio environment (3).

4. Conclusion

ABF system utilizing the GI in OFDM was proposed and evaluated through the experiments. It was shown that the ABF, which utilizes Head GI of the received signal at antenna elements and Tail GI of combined signal, had excellent performance even in the radio environment where the value of DUR was small. It is expected that ABF is more effective in the urban area where propagation with no line of sight is dominant. It is planned as further study to evaluate and verify the performance of the proposed system in real radio environments.

Acknowledgments The authors thank Mr. H. Asato (Magna Design Net, Inc.) and Mr. T. Tabata (Kojima Press Industry Co., Ltd.) for help with the experiments. Some of this research was conducted by a grant from Chubu Bureau of Economy, Trade and Industry in Japan.

References

- [1] S.Hori, N.Kikuma, and N.Inagaki, "MMSE Adaptive Array Utilizing Guard Interval in the OFDM Systems," Electronics and Commun. in Japan, Pt.1, Wiley Periodicals, Inc., Vol.86, No.10, pp.1-9, 2003.
- [2] J.Imai, M.Fujimoto, T.Shibata, N.Itoh, N.Suzuki, and K.Mizutani, "Experimental Results of Diversity Reception for Terrestrial Digital Broadcasting," IEICE Trans. Commun., Vol.E85-B, No.11, pp.2527-2530, 2002.