

# Low Sidelobe Linearly-Polarized Radial Line Slot Antenna using a Double-Layer Dipole Array Polarizer

Masahide Unno, Jiro Hirokawa, Makoto Ando

Department of Electrical and Electronic Engineering, Tokyo Institute of Technology  
S3-19, 2-12-1, O-okayama, Meguro-ku, Tokyo, 152-8552, Japan.

E-mail: [unno@antenna.ee.titech.ac.jp](mailto:unno@antenna.ee.titech.ac.jp)

## 1. Introduction

This paper presents a linearly-polarized radial line slot antenna (RLSA) with low sidelobes for a radar mounted in the head of an aircraft. The RLSA is a circular planar antenna [1] so that it would be better for a cone-shaped space of the head in comparison with conventional slotted waveguide array where each waveguide has different length.

We have two ways to realize the linear polarization using RLSA. One is to arrange slot sets with linear polarization on the antenna aperture [2] and the other is to place a polarization converter over a circularly polarized RLSA [3]. In the former case, the arrangement by the original set of two slots spaced by a half wavelength gave large reflection at the feed point. The reflection-canceling techniques such as beam-tilting [4] and modified configurations of the slot sets [5] made the antenna design more complicated. Therefore we take the latter case. In the circularly polarized RLSA, the arrangement by the original set of two slots spaced by a quarter wavelengths gives small reflection at the feed point. Use of a polarizer with no reflection can make the design of the polarizer independent from the design of RLSA. Double-layer of dipole arrays are used as the polarizer.

Taylor aperture distribution is adopted to suppress the sidelobes in RLSA [6]. The sidelobe-suppressed RLSA and the double-layer polarizer are designed independently. We show the aperture field distributions, the radiation patterns and the gain in the linearly-polarized antenna integrated with these two components.

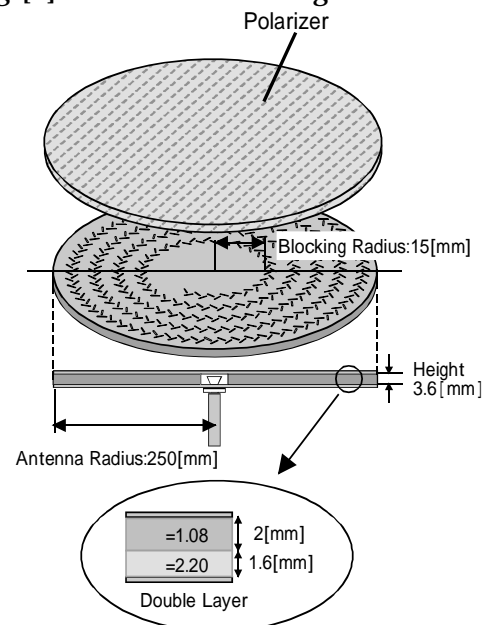

Fig.1 Configuration

## 2. Design of RLSA

Fig.1 shows the structure and the parameters of RLSA. RLSA is designed at 9.3GHz. The diameter is 250mm and the diameter of a blocking area at the center is 15mm. The waveguide has two dielectric layers. The relative permittivity is 1.08 in the upper layer and 2.20 in the lower layer. The effective relative permittivity is 1.41 in the waveguide.

The Taylor amplitude distribution for the circular aperture is determined for the sidelobe level of -40dB and  $n$  is 6. The excitation coefficient of each slot pair is sampled in the continuous tapered distribution. The slot length is changed to control the excitation coefficient.

Fig.2 shows the variation of the slot length in the radial direction. The variation for uniform amplitude distribution is added into this figure for comparison. The amplitude in the Taylor distribution near the center is stronger than that in the uniform distribution so that the slot length in the Taylor distribution near the center is longer than that in the uniform distribution. The amplitude at the edge is about -14dB of that at the center in the Taylor distribution.

The chain double-dashed lines in Fig.4-Fig.6 show the amplitude distribution, the phase distribution, and the radiation pattern in the design, respectively. The sidelobe level is -25.2dB, which becomes high due to the blocking area at the center. The antenna efficiency is 65%.

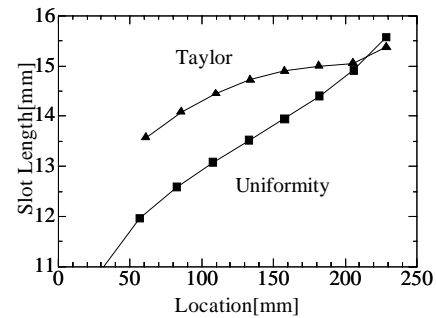

Fig.2 Slot Length

## 3. Design of Polarizer

The polarizer to transform circular polarization by the RLSA to linear polarization is double layer of dipole arrays etched two-dimensionally on a film. The two layers are placed with proper spacing to cancel the reflection. This means that the polarizer and the RLSA can be designed independently and they are placed at arbitrary spacing not to have high-order coupling.

The circular polarized wave is regarded as composition of the parallel component of electric field to dipoles and the perpendicular one with 90 degree phase difference. We design the polarizer so that the transmission factor for the parallel component is  $j$  because that for the perpendicular component is 1. Then the transmitted wave has linear polarization tilted by 45 degrees to the dipoles.

The width and the length of the dipoles are 1.0mm and 10.2mm. The transverse and the longitudinal spacings are 3.0mm and 13.3mm. The layer spacing is 3.0mm (0.09 wavelengths). This spacing is much thinner than a quarter wavelengths in conventional double-layer configuration for canceling reflection, because the slots have non-resonant length shorter than an half wavelength. The relative permittivity of the spacer is 1.08. Fig3 show the transmission and the XPD in the design. The XPD is under -20dB, and the transmission is larger than -0.5 dB in a range of 7.9 GHz – 9.6 GHz.

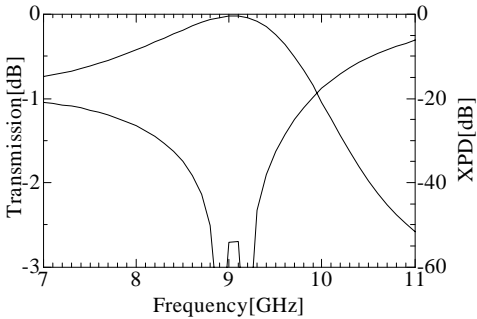

Fig.3 Trans. And XPD of Polarizer

4. Measurement Result

The dashed lines in Fig.4 and Fig.5 show the amplitude and the phase distributions by the RLSA without the polarizer in the radial direction in the measurement. The amplitude level at the edge is -14.6dB of that at the center. The phase difference is 50 degree. The dashed lines in Fig.6 and Fig.7 show the radiation pattern and directivity.

The measured sidelobe level is -21.7dB, which is higher by 3.5dB than the designed one. The antenna efficiency is 65%. The measured center frequency is shifted by 100MHz from the designed one.

The polarizer is placed on the RLSA with one-wavelength spacing (45mm). The solid lines and chain lines in Fig.4-Fig.7 correspond to the main polarization components and the cross polarization ones. The cross polarization level is about -12dB in the measurement, which is much higher than the design. This could come from reflection of the polarizer because of edching error in the dipole length. Then aperture phase changes 60 degrees in the radial direction, and the sidelobe level is -16.1dB

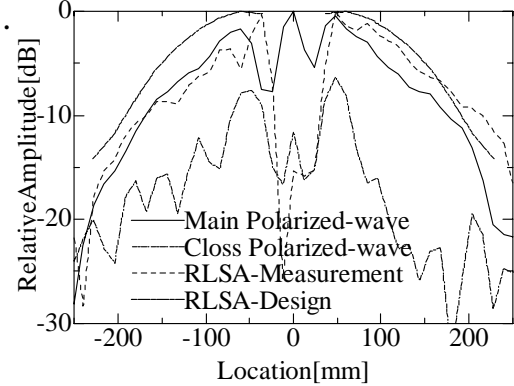

Fig.4 Aperture Amplitude

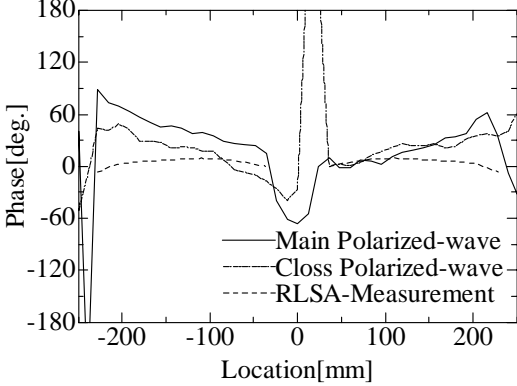
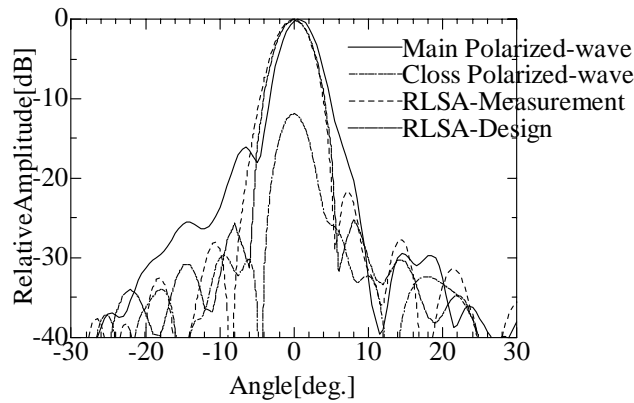
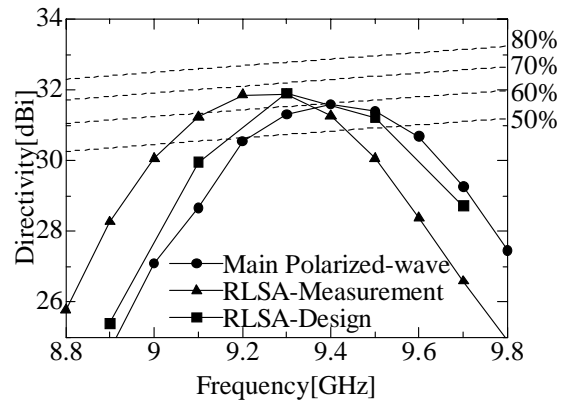

Fig.5 Aperture Phase



**Fig.6 Antenna Pattern**



**Fig.7 Directivity**

## 5. Conclusion

We have designed the sidelobe-suppressed circularly-polarized RLSA where the diameter is 250mm and the double-layer dipole polarizer with reflection cancellation at 9.3GHz. The side lobe level is -21.7dB, and the aperture efficiency is 65% in only RLSA. With the polarizer, the cross polarization level is about -12dB.

## References

- [1] N.Goto and M.Yamamoto, "Circular polarization radial line slot antennas," IEICE Technical Report, AP80-57, pp.43-46, August 1980 (in Japanese)
- [2] M.Ando, T.Numata, N.Goto, "A Linearly-Polarized Radial Line Slot Antenna," IEICE Technical Report, AP87, pp.19-26, Oct.1987 (in Japanese)
- [3] H.Uchida, et. "A Double-layer Dipole Array Polarizer for Planar Antenna," IEICE Technical Report, Vol.J79-B-2, No.8, pp.459-468, August 1996 (in Japanese)
- [4] J.Takada, M.Ando, N.Goto, "A Beam-Tilted Linearly Polarized Radial Line Slot Antenna", IEICE Technical Report, Vol.J71-B, No.11, pp.1352-1357, Nov.1988 (in Japanese)
- [5] T.Ikeda, J.Takada, M.Ando, N.Goto, "Slots Reflection Suppression of Linearly-Polarized Radial Line Slot Antennas", IEICE Technical Report, B-42, Sep.1989 (in Japanese)
- [6] M.Takahashi, et. "Low Sidelobe for Radial Line Slot Antennas," IEICE Technical Report, Vol.J79-B-2, No.9, pp.535-541, September 1996 (in Japanese)