

# A Broadband Rectenna For Harvesting Low-Power RF Energy

Heng Ye and Qing-Xin Chu

School of Electronic and Information Engineering,  
South China University of Technology, Guangzhou, 510641, China.

**Abstract** - This paper presents a broadband rectenna using the coplanar stripline (CPS). The radiator of the rectenna is a T-match dipole printed on a substrate. A silicon Schottky diode is shunted across the CPS as a rectifying device. The T-match dipole is designed to directly match the rectifying circuit within the operation band so that the bandpass filter between the antenna and rectifying circuit is eliminated. The RF-DC conversion efficiency of the rectenna is higher than 30% within the band from 1.7 GHz to 2.1 GHz at -2.5 dBm received power on a  $857 \Omega$  load, and the highest efficiency is 62.4%.

**Index Terms** — rectenna, broadband, low input power, coplanar stripline (CPS), conversion efficiency.

## 1. Introduction

Microwave power transmission (MPT) has gained a lot of attention as the rapid development of wireless communication. MPT is becoming an effective way to charge low-power electronic devices, such as radio frequency identification (RFID), wireless sensors. Rectennas, which can receive and convert the microwave power to dc power, are crucial parts in MPT systems. Consequently, the research on rectennas has become a hot spot [1]-[3]. However, most of those rectennas do not aim to broadband applications and require relatively high input RF power [1].

In this paper, a broadband rectenna using CPS is proposed. A broadband T-match dipole is adopted as the receiving antenna. A silicon Schottky diode is shunted across the CPS as a rectifying device. The CPS rectifying circuit is co-designed with the T-match dipole, and their matching performance is optimized for broadband operation at low input power. Therefore, the rectenna has the characteristics of broadband, low input power, high RF-DC efficiency, which can be applied to a variety of MPT systems.

## 2. Design

The proposed rectenna consists of a T-match dipole and a rectifying circuit as shown in Fig. 1. It is fabricated on a 1.6-mm-thick FR4 epoxy substrate with a dielectric constant of 4.4 and loss tangent of 0.02. The T-match dipole receives RF power and transmits it to the Schottky SMS7630-79 diode [4] through a coplanar stripline (CPS). The capacitor acts as a dc pass filter to prevent microwave power from reaching the load. A resistive load is placed at the end to extract the dc power. The receiving antenna is designed to directly match the rectifying within the operation band.

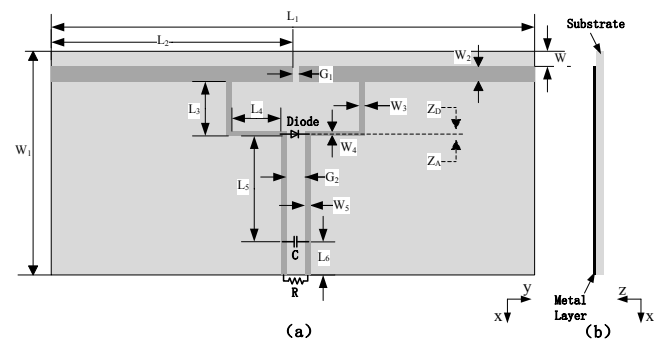

Fig. 1. Configuration of the proposed rectenna

(a) Top view (b) Side view

The parameters are:  $L_1=90\text{mm}$ ,  $L_2=44.85\text{mm}$ ,  $L_3=9.5\text{mm}$ ,  $L_4=8.2\text{mm}$ ,  $L_5=26.6\text{mm}$ ,  $L_6=4.9\text{mm}$ ,  $W_1=47\text{mm}$ ,  $W_2=3\text{mm}$ ,  $W_3=0.5\text{mm}$ ,  $W_4=0.5\text{mm}$ ,  $W_5=0.3\text{mm}$ ,  $W=3.2\text{mm}$ ,  $G_1=0.3\text{mm}$ ,  $G_2=1.4\text{mm}$ ,  $R=857\Omega$ ,  $C=330\text{pF}$

The soft-ware Advanced Design System (ADS) has been used to calculate the input impedance of the rectifying circuit. A rectifying circuit model is optimized under low input power with the goal of broadband performance. After optimization, the rectifying circuit's input impedance is  $120-j160\Omega$ . Thus, the receiving antenna needs to be inductive to conjugate match rectifying circuit. It can be achieved by using an inductive feed method [2]. The impedance match network is realized by the T matching network with the width of  $W_3$ ,  $W_4$ , the length of  $L_3$ ,  $L_4$ , and the gap of  $G_1$ . Fig.2 shows the simulated input impedance of receiving antenna versus the frequency. It can be seen that the receiving antenna and rectifying circuit can be well conjugate matched.

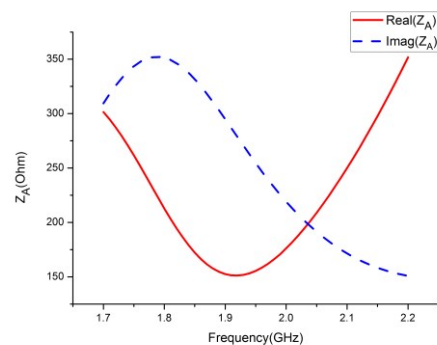

Fig. 2. Input impedance of the antenna versus the frequency.

The receiving antenna fed by CPS cannot be measured directly. Therefore, the receiving antenna needs a CPS-to-microstrip transition to transform the CPS to a 50-microstrip[4]. The antenna with transition and matching circuit is shown in Fig. 3(a). Fig. 3(b) shows its  $S_{11}$ , a good agreement can be found between simulated and measured results. The power received by the rectenna can be measured using the antenna with transition circuit.

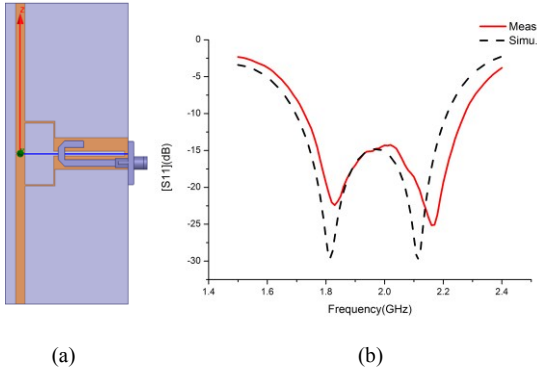

Fig. 3.(a) Configuration of the antenna with transition circuit. (b)  $S_{11}$  of the antenna.

### 3. Measurement

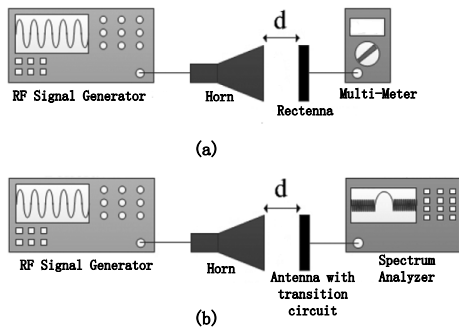

Fig. 4. The measurement system

In the measurement system as shown in Fig. 4, the RF power generated by a RF signal generator radiated from a horn antenna into the space. The power received by the rectenna is adjusted to be  $-2.5\text{dBm}$  by the antenna with transition circuit as shown in Fig. 4.(b), and The output DC voltage of the rectenna is measured by a multi-meter as shown in Fig. 4.(a). The photograph of the recenna is shown in Fig.5



Fig. 5. Photograph of the rectenna

The RF-DC conversion efficiency of the rectenna can be calculated by

$$\eta = \frac{V_L^2 / R_L}{P_{RF}}$$

where  $V_L$  is the measured output dc voltage on the load resistance and  $P_{RF}$  is the measured RF power delivered to the rectifying circuit.

The simulated and measured output dc voltage and RF-DC conversion efficiency of the rectenna is shown in Fig. 6 and Fig. 7, respectively. It can be seen that the measured efficiency is higher than 30% from 1.7 GHz to 2.1 GHz, which reveals a broadband performance.

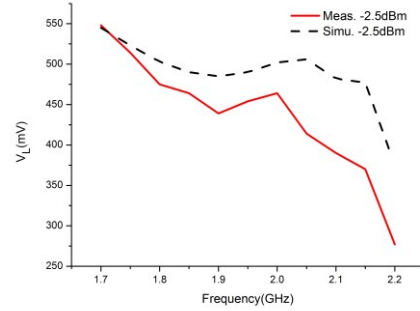

Fig. 6. The output voltage of the rectenna.

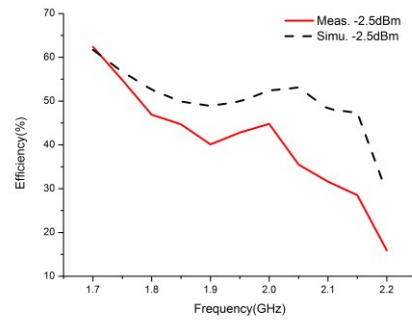

Fig. 7. The efficiency of the rectenna.

### 4. Conclusion

A broadband rectenna has been proposed for harvesting low-power. The RF-DC conversion efficiency of the rectenna is higher than 30% within the band from 1.7 GHz to 2.1 GHz at  $-2.5\text{ dBm}$  received power on a  $857\Omega$  load, and the highest efficiency is 62.4%.

### References

- [1] M. J. Nie, X-X. Yang, G-N. Tan, B. Han, "A Compact 2.45-GHz Broadband Rectenna Using Grounded Coplanar Waveguide," *IEEE Antennas Wireless Propag. Lett.*, vol. 14, pp. 986 - 989, 2015.
- [2] G. Marrocco, "The art of UHF RFID antenna design: Impedance matching and size-reduction techniques," *IEEE Antennas Propagat.Mag.*, vol. 50, no. 1, pp. 66 - 79, Feb. 2008.
- [3] H. Sun, Y-X. Guo, M. He, and Z. Zhong, "Design of a high-efficiency 2.45-GHz rectenna for low-input-power energy harvesting," *IEEE Antennas Wireless Propag. Lett.*, vol. 11, pp. 929 - 932, 2012.
- [4] Skyworks Solutions, Inc. Surface Mount Mixer and Detector Schottky Diodes. [Online]. Available: [http://www.skyworksinc.com/Product/511/SMS7630\\_Series](http://www.skyworksinc.com/Product/511/SMS7630_Series).