

# 60 GHz Membrane Antennas fed by Substrate Integrated Waveguide

# Tristan SARRAZIN<sup>1,2</sup>, Hamsakutty VETIKALLADI<sup>1</sup>, Olivier LAFOND<sup>1</sup>, Mohamed HIMDI<sup>1</sup>, and Nathalie ROLLAND<sup>2</sup>

<sup>1</sup>IETR, University of Rennes1, France, tristan.sarrazin@univ-rennes1.fr.

<sup>2</sup>IEMN, University of Lille1, France, nathalie.rolland@iemn.univ-lille1.fr.

## 1. Introduction

MODERN multimedia applications demand higher data rates. This has been recently proven by the accelerating sales of IEEE 802.11 family WLAN hardware. Current WLANs are, however, capable of delivering only 30-100 Mb/s connection speeds, which is insufficient for future applications like wireless high-quality video conferencing. For these and many other purposes, more capacity, wirelessly, is needed. Service provided by IEEE 802.11 WLANs only fulfills the needs of normal internet users and office workers. But, bandwidth demands are still rising. In such a context, 60 GHz millimeter wave (MMW) systems constitute a very attractive solution, due to the fact that there is a several GHz unlicensed frequency range available around 60 GHz, almost worldwide[1]. This massive spectral space enables densely situated, non-interfering wireless networks to be used in the most bandwidth-starving applications of the future, in all kinds of short-range (< 1 km) wireless communication. It enables up to gigabit-scale connection speeds to be used in indoor WLAN networks or fixed wireless connections in metropolitan areas. The IEEE standards in this band are IEEE 802.11.ad for high speed WLAN and IEEE 802.15.3c for HDTV application.

Requirements generally specified for antennas used in mm-wave systems concern gain, radiation efficiency, operating bandwidth, technological reliability, cost and compatibility with other RF modules. Significant efforts have been made during the past few years for designing and implementing efficient miniaturized antennas for mobiles or radio communications equipments. Millimeter wave antennas with silicium technology are developed and are explained in [2]. But in this case the problem of antenna integration is not easy to have a good gain. Hence membrane antenna technology is a good solution, because an air cavity can be done in silicium to improve antenna performances. This membrane can be done with thin silicium or BCB material as explained in [3], for 60 GHz beam forming application. Rectangular waveguides are widely used in microwave engineering, particularly at millimeter wave frequencies, due to their advantages of low losses, high power handling, and high isolation. But, applications of waveguides at millimeter wave frequencies are still limited by high manufacturing cost, relatively large volumes, and difficulties of integration with other components. Recently, the substrate integrated waveguide (SIW) technique has been proposed [4] which maintains the advantages of rectangular waveguides as well as additional merits (e.g., ease of integration, low cost, and reduced size). Conventional printed circuit board (PCB) processes can be used to realize SIW-based structures and reduce manufacturing cost. For example, a 79 GHz slot antennas based on SIW on a flexible printed circuit is explained in [5]. In this case the prototypes are fabricated on a polyimide flex foil using printed circuit board (PCB) fabrication processes. Micromachining process is used to make the walls on SIW, which is expensive and not an easy process. The losses are very high and hence the efficiency of all the prototypes explained on that paper is very low.

In this paper, the authors are proposing a very low cost membrane antenna technology based on FR4 and pyralux substrate. A single and 1x4 array of membrane supported microstrip patch antennas (MPA) fed by substrate integrated wave technology are designed and characterized.

## 2. Substrate integrated waveguide(SIW) technology

### 2.1 SIW single patch antenna design

The 2-D view of the aperture-coupled MPA fed by Substrate Integrated Waveguide (SIW) is shown in Fig. 1a with slot in a longitudinal arrangement. We used a very thin pyralux substrate

(75 microns) for the SIW and it is not classical when compared to others work where thick substrate is used to avoid loss in waveguide [6]. We want to design SIW on thin substrate to add easily active components even if we know that the loss will increase. The proposed MPA and its feeding structure are implemented on two dielectric layers, MPA-SUB, and SIW-SUB, made of the same new low-loss/cost material, where the SIW is formed by buried metal via holes. The SIW (*Layer 1, layer 2, layer 3*) as shown in Fig. 1b, which is integrated on SIW-SUB, is formed with metallic holes, and closely aligned metallic holes via arrays that serve as two sidewalls separated by width  $W_{siw}$  (so the cut off frequency for the  $TE_{10}$  mode is  $\sim 38.7$  GHz) and are electrically connected to the top and bottom metallic layers. The vias diameter ( $d_{via}$ ), and all the antenna parameters are given in Fig. 1a.

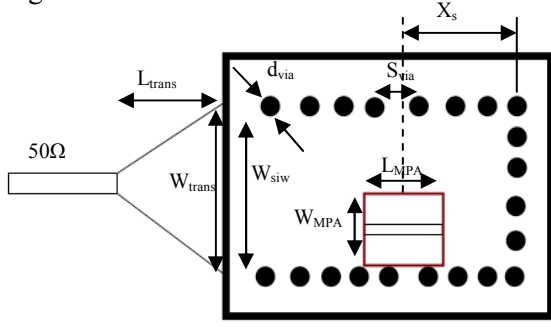

Fig. 1a. 2D view of SIW antenna.  $W_{siw} = 2.5$  mm,  $d_{via} = 0.4$  mm,  $S_{via} = 0.6$  mm,  $L_{MPA} = 1.7$  mm,  $W_{MPA} = 1.5$  mm,  $L_{slot} = 1.8$  mm,  $W_{slot} = 0.35$  mm,  $X_s = 2.9$  mm,  $W_{trans} = 2.48$  mm,  $L_{trans} = 2$  mm.

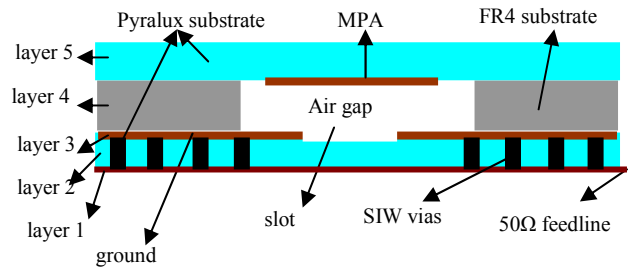

Fig. 1b. Side view of SIW antenna.

The total antenna consists of five layers as shown in Fig 1b. The radiating element, MPA of dimension  $1.7 \times 1.5$  mm<sup>2</sup> is realized on the bottom surface of MPA-SUB. It is supported by FR4 substrate of thickness 200  $\mu$ m by providing an air gap of  $2.5 \times 2.5$  mm<sup>2</sup> under the MPA. The MPA-SUB, SIW-SUB and FR4 substrates are glued with a thin sheet of 3M glue of approximately 40 $\mu$ m. All the layers are then binded at low temperature to avoid the membrane bending. Since the thickness of the 3M glue sheet is 40  $\mu$ m, the total height of the air column is 280  $\mu$ m (i.e 200  $\mu$ m + 40  $\mu$ m x 2). It is excited by longitudinal slot ( Fig. 1 (a) ) located on the top ground plane of SIW structure (on *Layer 3*) at a distance from the SIW short-circuited, as shown in Fig. 1a. Usually the distance ( $X_s$ ) between the center of the slot and the shorted end of the waveguide is a quarter of the guided wavelength. However, this distance is chosen to be three quarter of the guided wavelength in all the presented antennas due to limitations in the present manufacturing processes (i.e. if we took  $\lambda_g/4$ , then the distance between the SIW short end and the centre of slot is very small which is less than the minimum manufacturing distance). Hence the coupling distance has to be chosen in the vicinity of  $\sim 3\lambda_g/4$  (Fig. 1(a)) ( $\lambda_g$  is the guided wavelength). A microstrip to waveguide transition is used to excite the waveguide as shown in Fig. 1a. The electromagnetic (EM) solver CST Microwave Studio is used to design the antenna.

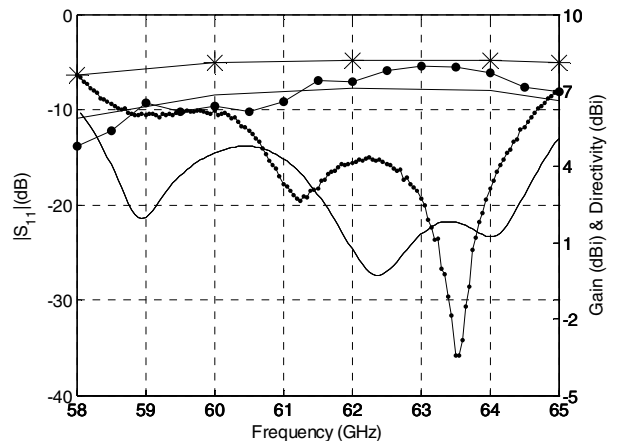

Fig. 2. Comparison of simulated and measured results of S11 and gain, simulated directivity . S11 & gain simulated —, S11 & gain measured —●—, simulated directivity —\*—.

Fig. 2 shows the comparison of simulated and measured antenna reflection coefficient  $S_{11}$ (dB). The measured  $S_{11}$  is in between 58.5 GHz to 64.5 GHz (10%). The maximum measured gain is 7.9 dBi, where as the simulated maximum directivity is 8.2 dBi. The estimated efficiency is 93%. The simulated and measured radiation patterns of the proposed antenna are shown in Figs. 3(a) and 3(b) in both E - (Horizontal plane) and H-(Elevational plane) planes, respectively, at 62 GHz. There is a small oscillation in elevational plane radiation pattern which is due to the diffraction effects. There is a good cross polar ratio of less than -18 dB for all the frequencies in the band.

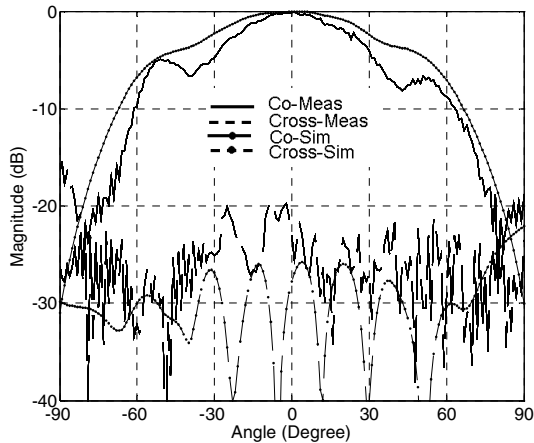

Fig.3a. The simulated and measured E-plane radiation patterns.

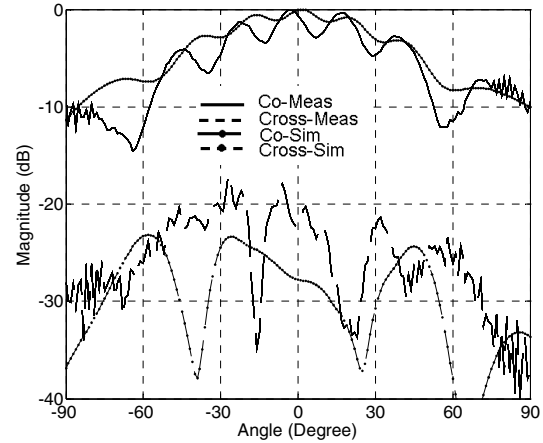

Fig.3b. The simulated and measured H-plane radiation patterns.

## 2.2 SIW 1 x 4 patch antenna array

The photograph of the back view of the 1x4 SIW antenna array is shown in Fig.4. The distance between the elements in the array (array factor) is 2.9 mm , i.e  $0.58\lambda_0$  at 60 GHz (inner distance of SIW is 2.5 mm+ via diameter 0.4 mm). All the antenna parameters like slot length, patch size etc. are same as that of single patch. In order to achieve maximum directivity, the linear patches are uniformly excited through a feed network. The total size of the antenna is taken as 30 mm x 30 mm for the measurement purpose.



Fig.4. Back view of the SIW-based one-by-four slot array antenna.

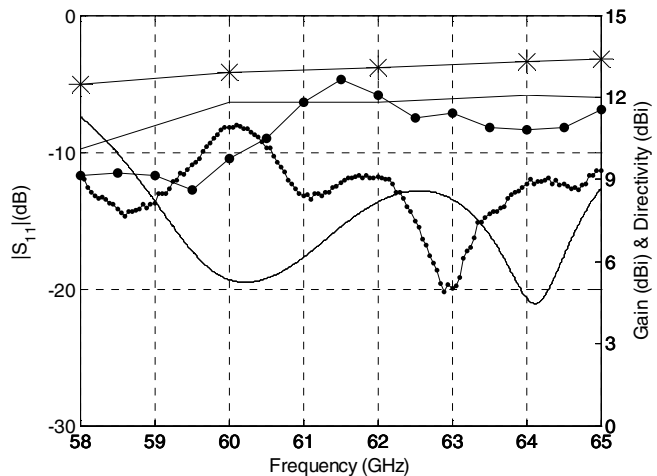

Fig.5. Comparison of simulated and measured results of  $S_{11}$  and gain, simulated directivity.

$S_{11}$  & gain simulated—,  $S_{11}$  & gain measured—●, simulated directivity—\*.

The simulated and measured  $S_{11}$  results are given in Fig.5. The measured  $S_{11}$  is matched from 60.5 GHz to 65 GHz (7.5%). There is a frequency shift in the band which may be due to the effect of V-conductor. The maximum gain measured is 12.6 dBi with a maximum directivity of 13.3 dBi. The

estimated efficiency of this array is 85%. The measured and simulated E plane radiation patterns at 62 GHz are shown in Fig.6. It is found that the simulated and measured results are in good agreement. The cross polar level is lower than -15 dB. This level may be due the non perfection in the manufacturing of the SIW and which results the leakage on the walls of the SIW, and the diffraction from the V-connector. The 3 dB beam width at 62 GHz is 24°.

In order to study the back radiation of SIW antenna array compared to the conventional aperture coupled antenna array, we did the measurements of 1 x 4 array of SIW and classical slot coupled prototypes. Fig. 7 shows the comparison of back side to front side pattern ratio of aperture coupled classical 1x4 array and SIW slot coupled 1 x 4 array at 62 GHz. It is found that back radiation is very low for SIW antenna in all the frequencies in the band and is higher for classical slot coupled antenna because of the radiation from the slot and the serial stub.

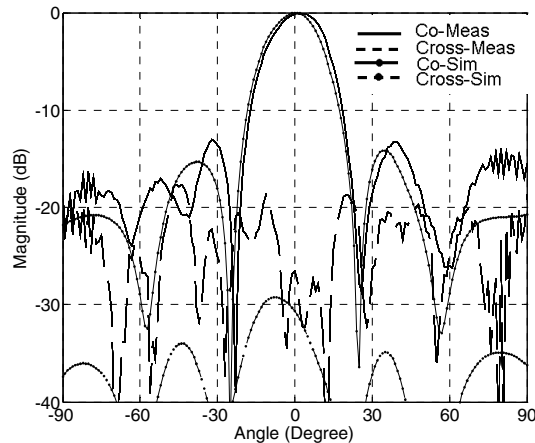

Fig.6 The simulated and measured E-plane radiation pattern.

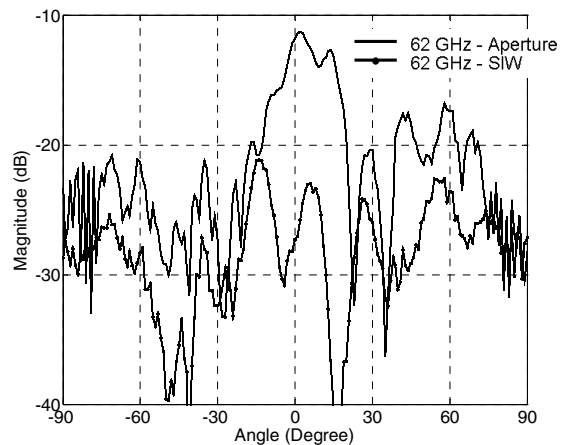

Fig. 7 Comparison of back radiation of microstrip fed aperture coupled 1x4 array and SIW fed aperture coupled 1x4 array.

In conclusion, membrane supported slot coupled MPA/array fed by a substrate waveguide technology is very good in terms of bandwidth, gain, very low back radiation and high efficiency and hence is highly suitable for 60 GHz applications.

## REFERENCES

- [1] P.F.M. Smulders, "60 GHz radio: prospects and future directions", Proceedings Symposium IEEE Benelux Chapter on Communications and Vehicular Technology, Eindhoven, 2003, pp.1-8.
- [2] S. Montusclat, F. Giancesello, D. Gloria, "Silicon full integrated LNA, filter and antenna system beyond 40 GHz for MMW wireless communication links in advanced CMOS technologies," in Proc. IEEE Radio Frequency Integrated Circuits Symp., pp. 77-80, 2006.
- [3] A. Adane, F. Gallee, C. Person, V. Puyal, C. Villeneuve, D. Dragomirescu, "Implementation of Broadband microstrip-U Coupled Patch Array on Si/BCB Membrane for Beamforming Applications At 60 GHz" , Proceedings of the 5th European Conference on Antennas and Propagation (EUCAP), 2011.
- [4] D. Deslandes, K.Wu, "Integrated microstrip and rectangular waveguide in planar form," IEEE Microw Wireless Compon. Lett., vol. 11, pp. 68–70, Feb. 2001.
- [5] S. Cheng, H. Yousef, H. Kratz , "79 GHz Slot Antennas Based on Substrate Integrated Waveguides (SIW) in a Flexible Printed Circuit Board", IEEE Transactions on Antennas and Propagation, Vol. 57, No. 1, January 2009, pp. 64-71
- [6] W. M. Abdel-Wahab, S. Safavi-Naeini, "Wide-Bandwidth 60-GHz Aperture-Coupled Microstrip Patch Antennas (MPAs) Fed by Substrate Integrated Waveguide (SIW)", IEEE Antennas and wireless propagation letters, Vol. 10, 2011, pp.1003-1005.