

Dual-polarized Corporate-feed Plate-laminated Waveguide Slot Array Antenna for 60 GHz-band

[#]Dongjin Kim, Miao Zhang, Jiro Hirokawa, Makoto Ando

Dept. of Electrical and Electronic Eng., Tokyo Institute of Technology

S3-19, 2-12-1 O-okayama, Meguro-ku, Tokyo, 152-8552, Japan, djdkim@antenna.ee.titech.ac.jp

1. Introduction

Most of the studies on the dual-polarized array antennas use microstrip patches and lines because of the easy realization of the radiating elements and the feeding networks. A variety of feeding techniques to achieve high isolation and good cross-polarization have been demonstrated [1, 2]. However, most of these require double-layer or multilayer substrates and the structures are too complicated. It is still difficult to fabricate dual-polarized array antennas in mass production. Also, the microstrip antennas are not suitable in the millimeter wave bands due to the large loss of the substrates.

On the other hand, the waveguide slot array antenna, which has advantages of low profile, low cross-polarization level and very low transmission loss, is widely employed in the millimeter wave band. However, it has disadvantages of narrow bandwidth and beam squint when the slots are series-fed. The double-layer corporate-feed waveguide slot array antenna [3], where the feeding circuit is located in the bottom layer underneath the radiating waveguides in the top layer has been developed for wideband operation and to avoid the beam squint. To realize the double-layer structure, we have introduced a new fabrication method called 'diffusion bonding of laminated thin metal plates'. The method provides a high degree of accuracy and mass productivity with low cost. In addition, we can easily realize multi-layer structure. A 16x16 element array is designed and fabricated in the 60 GHz band. A high gain of 32 dBi as well as a wide bandwidth of 8 % for the high antenna efficiency of more than 80 % is achieved.

Based on the antenna structure in [3], we propose a dual-polarized waveguide slot array antenna. We already have proposed a dual-polarized feeding structure having wide bandwidth and high isolation using multi-layer structure which is can be fabricated by the diffusion bonding technique [4]. In this paper, we will describe the antenna design including the radiating and the feeding structures .

2. Antenna Configuration

Fig. 1 shows the antenna configuration designed at 61.5 GHz. There are 16x16 radiating slots with 0.86 wavelength interval on the top layer fed by two full-corporate feeding networks on the bottom layers. The aperture area is defined as 67.2 mm square (16 elements x 4.2 mm spacing). The total height of the antenna is 6.3 mm using 21 plates with 0.3mm thickness.

2.1 2x2-element Subarray Unit

A 2x2-element array is designed as a unit to be fed by the corporate-feed structures. Fig. 2 shows the exploded perspective view of the 2x2-element array unit. Two sets of periodic boundary walls in the x and y directions are assumed to include the external mutual coupling in the two-dimensional infinitely array. The longitudinal magnetic field in the y-direction (x-pol.) is to be excited by the feeding waveguide 1 while the transverse magnetic field in the x-direction (y-pol.) is to be excited by applying the cross slot in the feeding waveguide 2. The realization of high isolation is very promising between the two ports, because the longitudinal coupling slot locates at the center of the feeding waveguide 2 not to couple at all. Also the large thickness of the longitudinal coupling slot located between the two feeding waveguides contributes the fast attenuation of the higher-order

modes excited by feeding waveguide 1. Two orthogonal linear polarizations are excited at same time by the radiating part through the coupling slot 2.

Fig. 3 shows the operation mechanism of the radiating 2x2-elements for the single polarization [3]. They are excited through the coupling slot located underneath the cavity. On the other hand, Fig. 4 shows the coupling mechanism of the dual-polarization. The operation mechanism is principally same with the single-polarization, but the radiating slots and the coupling slot are changed into the cross-shape to have dual-polarization. Also, the cavity shape is changed into symmetrical structure. To suppress the cross-polarization in radiation, the narrow width is employed in the radiating slots and the coupling slot. The cavity structure is also optimized for low cross-polarization level.

2.2 Multi-layer Feeding Structure

To realize the feeding structure for the dual-polarization, we compose a 3-layer feeding structure. Fig. 5 shows the specific structure we propose for the 4x4 element array. The 2x2-element is placed on each end of this feeding network. As it is explained above, the longitudinal magnetic field is to be excited by the corporate feeding circuit placed in the first layer while the transverse magnetic field is to be excited by the second layer. The third layer is introduced to excite in-phase for the transverse slots on the second layer. The transverse slots neighbored up and down would be excited in alternating phase, if the third layer was not introduced. The arrow shows the magnetic field on each coupling slot. By the expansion of this structure, the full-corporate feeding network for the 16x16-element array is easily realized.

3. 16x16-element Simulation Results

Fig.5 shows the calculated frequency characteristics of the reflection of the 16x16-element array antenna. The bandwidths for the two polarizations are 5.0% (*x*-pol.) and 8.1% (*y*-pol.) for VSWR less than 1.5. The high isolation over 55 dB is achieved between the 2 ports over a broad frequency bandwidth of more than 10%. Fig. 6 shows the frequency characteristic of the antenna gain and efficiency. The peaks of the gain are 32.5 dBi with 75% antenna efficiency at 61.5 GHz and 32.5 dBi with 72% antenna efficiency at 62.8 GHz for the longitudinal and transverse polarizations, respectively, where the conductivity of copper is assumed to be 5.8×10^7 S/m. The 1-dB down gain bandwidths are 7.2% and 8.8%, respectively. Fig. 7 and Fig. 8 show radiation patterns of the *x*-pol. fed by waveguide 1. When the $\phi=0^\circ$ (Fig. 7), the cross-polarization level is suppressed below -30 dB in all angles of θ , however, when the $\phi=45^\circ$ (Fig. 8), the cross-polarization level is increased up to -15 dB around $\theta=58^\circ$. The width of the radiating slots is the key parameter of the cross-polarization, however it also affects on the reflection bandwidth. The width of the radiating slot is optimized considering the cross-polarization level and the reflection bandwidth because they show trade-off relationship. Radiating patterns for *y*-pol. also show same phenomenon with those for *x*-pol.

4. Summary and Discussion

The dual-polarized corporate-feed waveguide slot array antenna is designed for the 60GHz band. Using the multi-layer structure, we have realized dual-polarization operation. Even though the gain is approximately 1 dB lower than the antenna for the single polarization in [3] due to the -15dB cross-polarization level in $\theta=58^\circ$, this antenna still shows very high gain over 32 dBi over the broad bandwidth. This antenna will be fabricated and measured in future.

References

- [1] K. Wong and T. Chiou, "Broad-band dual-polarized patch antennas fed by capacitively coupled feed and slot-coupled feed," *IEEE Trans. Antennas Propag.*, vol. 50 no. 3, pp. 346-351, Mar. 2002.
- [2] K. Tsukamoto and H. Arai, "Characteristics of dual-polarized flat antennas," *IEICE Trans. Commun.*, vol. J79-B, no. 8, pp. 476-485, Aug. 1996.
- [3] Y. Miura, J. Hirokawa, M. Ando, Y. Shibuya and G. Yoshida, "Double-layer full-corporate-feed hollow-waveguide slot array antenna in the 60-GHz band," *IEEE Trans. Antennas and Propag.*, vol. 59, no.8, pp.2844-2851, Aug. 2011.
- [4] D. Kim, M. Zhang, J. Hirokawa and M. Ando, "Feeding Structure to Widen Bandwidth for Dual-polarization Corporate-feed Waveguide Slot Array Antenna," *Proc. of ISAP 2011*, Session: Poster I, Oct. 2011.

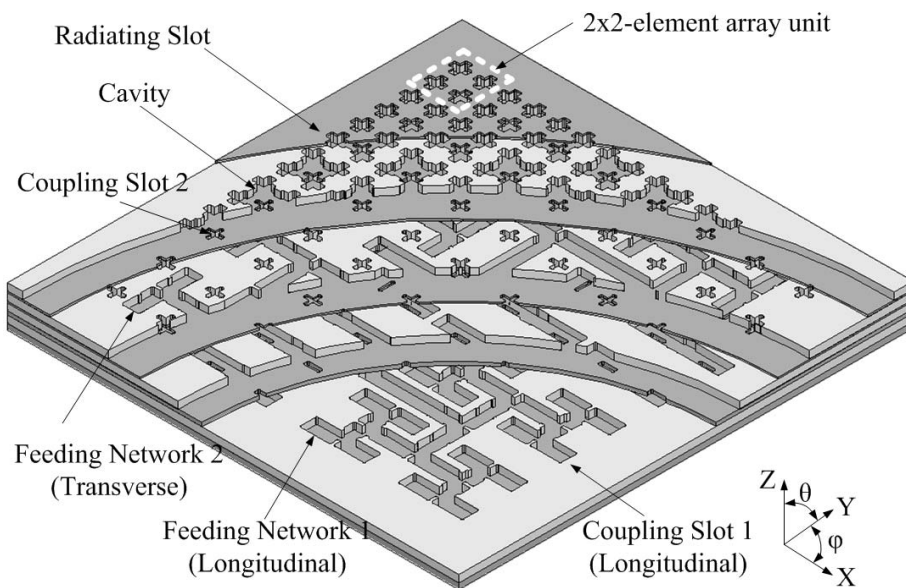

Figure 1: Antenna Configuration.

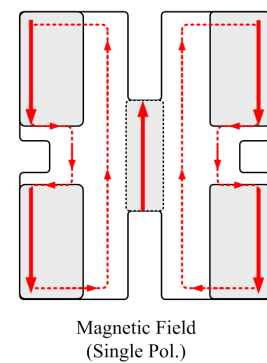

Figure 3 Operating Mechanism of Single-polarization.

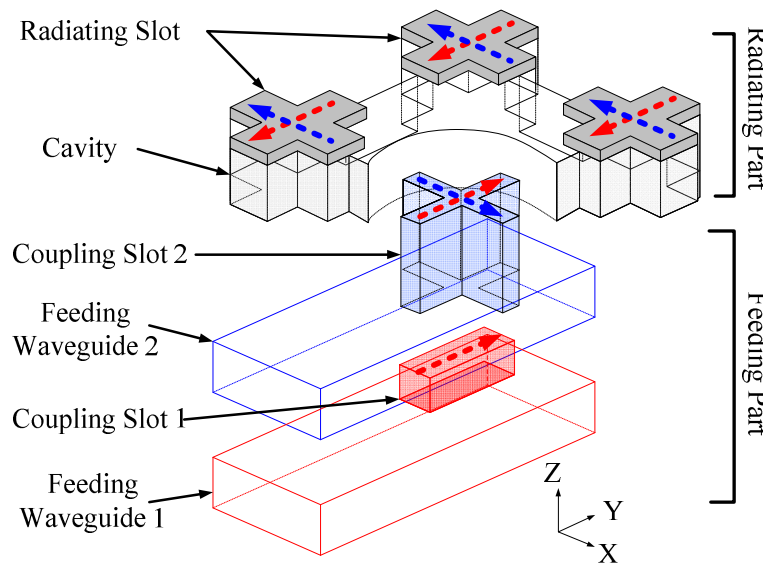

Figure 2: 2x2-element Array Unit.

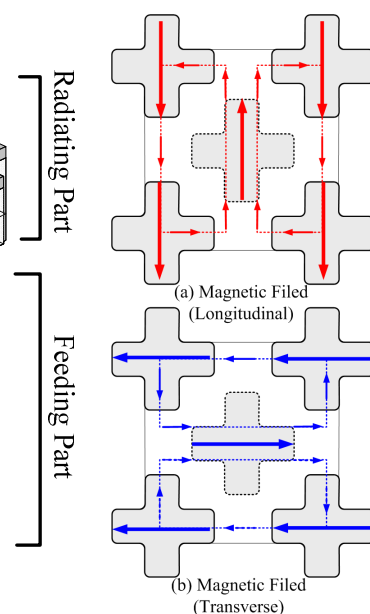

Figure 4: Operation mechanism of Dual-polarization.

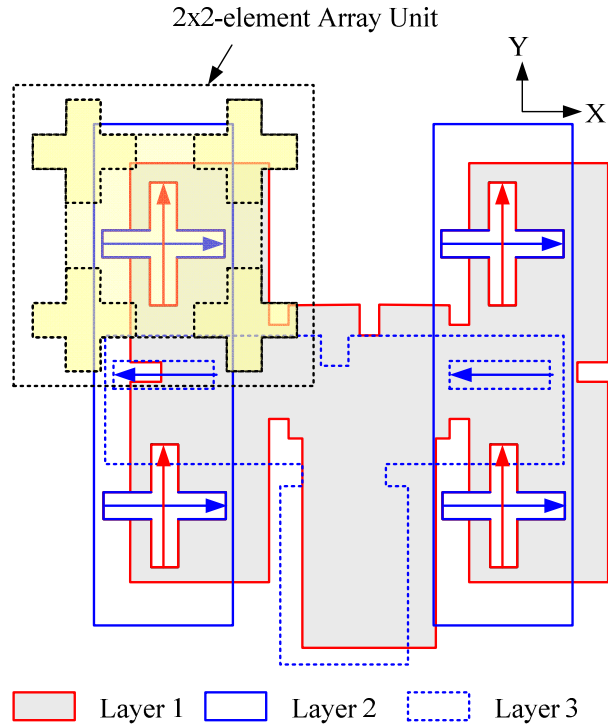

Figure 5: Corporate feed of 4x4 slots to excite both of longitudinal and transverse components.

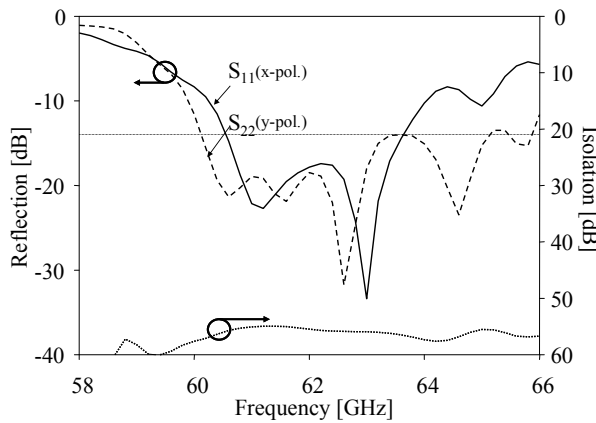

Figure 6: Antenna reflection.

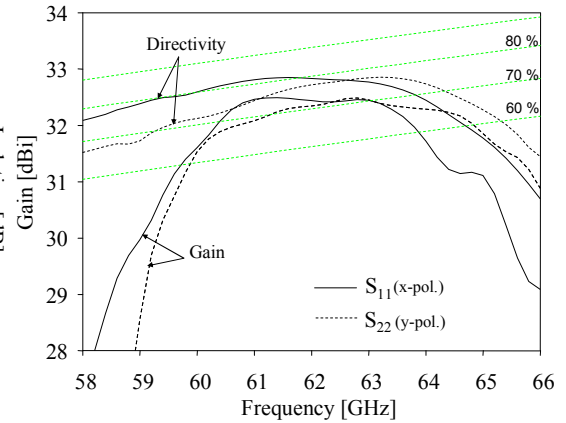

Figure 7: Antenna gain and efficiency.

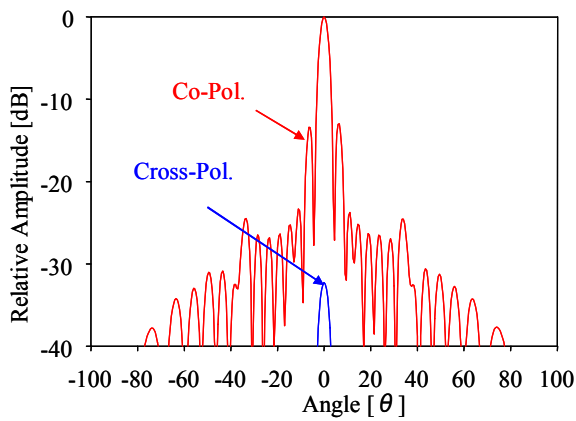

Figure 8: Radiation pattern(x-pol, $\phi=0^\circ$)

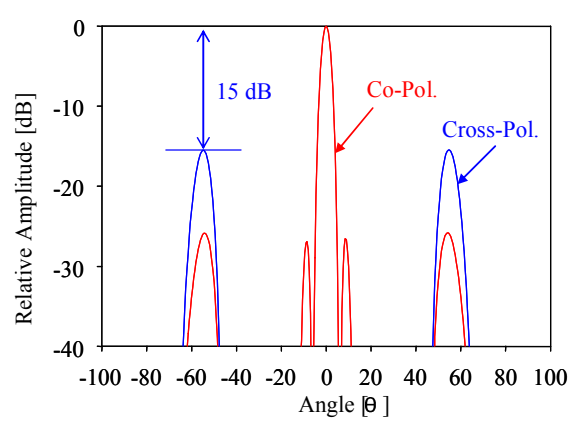

Figure 9: Radiation pattern(x-pol, $\phi=45^\circ$)