

Single-Feed Multiple Slotted Triangular Microstrip Antenna for Dual-Band Circular Polarization

W. K. Lee, S. M. Kim, W. G. Yang

Department of Electronics Engineering, University of Incheon,
177 Dowha 2-dong, Nam-gu, Incheon, 402-749, KoreaE-mail: wgyang@incheon.ac.kr

1. Introduction

Microstrip patch antennas provide the favorable features such as thin and flat profile and low production cost. And many cases of the satellite radio broadcasting and communication, circular polarization(CP) is used[1,2]. The main advantage of single-feed CP microstrip antennas is their simple structures that do not require any external polarizer. They can, therefore, be realized more compactly by using less board space than the dual-feed CP microstrip antennas. Many designs of single-feed CP microstrip antennas with square or circular patches have also been reported[3,4].

Generally, single feed patch antenna radiates linear polarization. A single patch antenna can be made to radiate circular polarization if two orthogonal modes are simultaneously excited with equal amplitude and $\pm 90^\circ$ out of phase with the sign determining the sense of rotation[5]. The dual-band design of a single-feed rectangular microstrip antenna with a pair of narrow slots placed close to its radiating edges has been reported recently[6].

In this paper, we propose a dual-band CP antenna by applying a similar but different slot-loading arrangement to a triangular microstrip antenna. This proposed dual-band CP design is achieved by loading multiple slots in the triangular patch. Dual-band CP of proposed antenna is generated by single feed and multiple slots, frequency ratio of low-band and high-band is adjusted by adjusting size and location of slots in the proposed antenna.

At first, we will show a configuration for dual band CP antenna in chapter 2 and simulation and experimental results will be in chapter 3. At last, the chapter 4 is conclusion.

2. Antenna Configuration

The geometry of the proposed dual-band CP design is shown in Fig. 1. The triangular patch has a side length of L_1 and is printed on a substrate of thickness h and relative permittivity ϵ_r . Three slots with length of L_2 , are placed in parallel to the each side edges of the triangular patch, with a small distance L_3 away from the each side edges. The triangular microstrip patch is fed by using a coaxial probe with 50Ω SMA connector. The coaxial probe is located slightly below the center of the patch. To radiate good CP waves from a triangular microstrip antenna with a single-feed, the patch must be fed at an optimum feed location. Table 1 shows parameter of the proposed antenna.

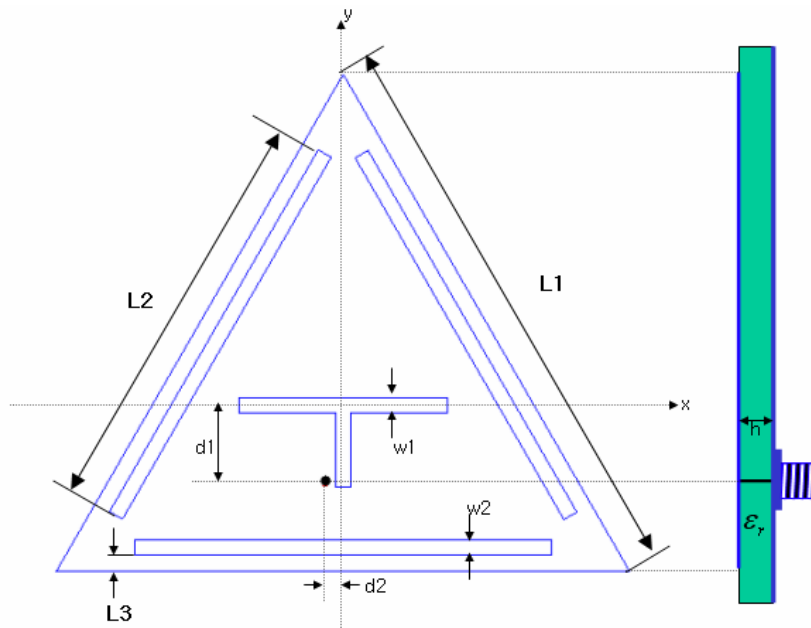

Fig. 1. Geometry of the proposed antenna.

Table 1. Parameters of the proposed antenna.

L1(mm)	L2(mm)	L3(mm)	d1(mm)	d2(mm)	h(mm)	w1(mm)	w2(mm)	f1(GHz)	f2(GHz)
75.0	56.0	0.6	10.5	2.2	5.0	2.00	2.00	1.992	2.645

3. Simulation and Experimental Results

The characteristics of the notched patch antenna have been simulated by using Ansoft Ensemble software, which is based on the moment method. Simulated characteristic parameters such as S_{11} , impedance loci, axial ratio are shown in Fig. 2. In simulation, we set the thickness of the dielectric(foam) to 1mm and without radome.

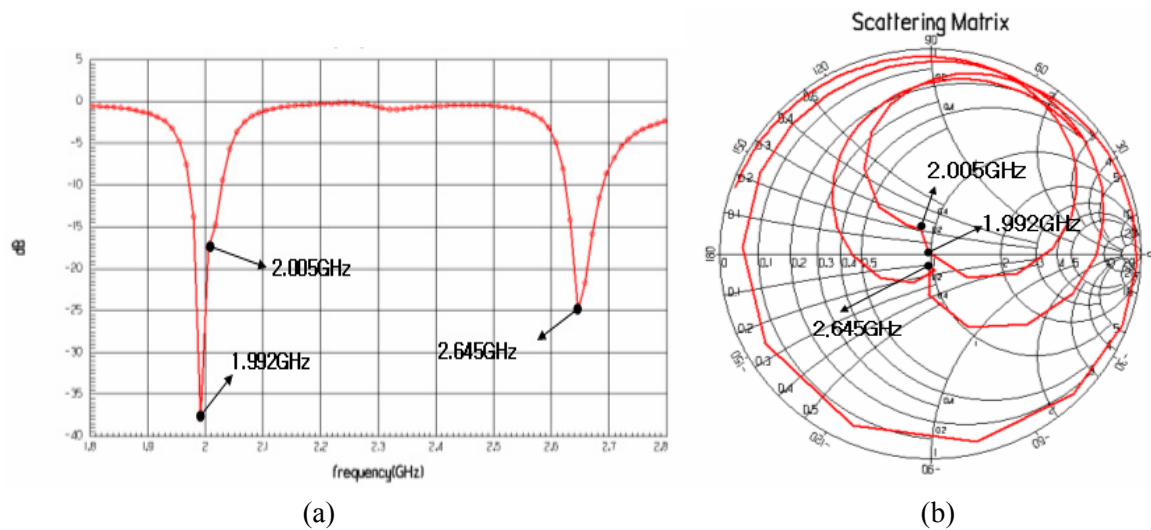

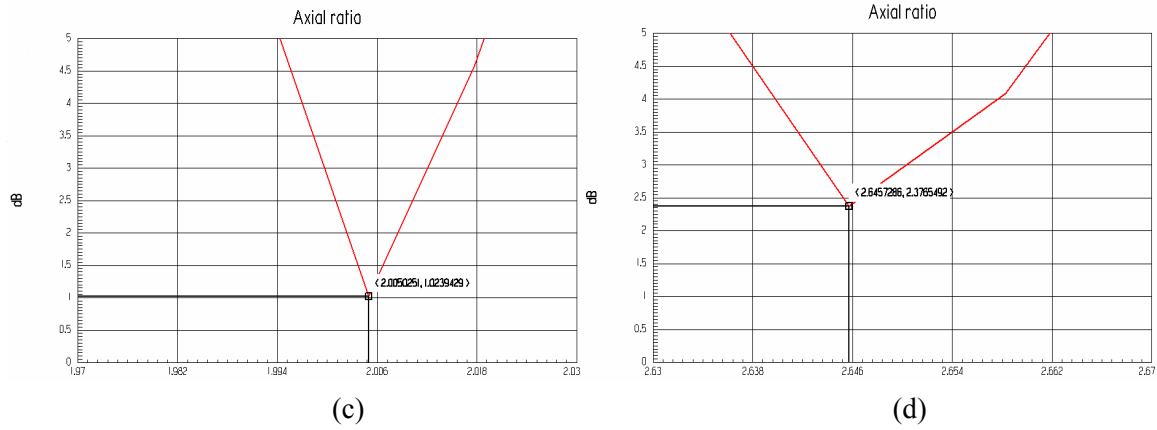

Fig. 2. Electrical characteristics of the proposed antenna.

- (a) S_{11} , (b) Impedance loci,
(c) Axial ratio of low-band, (d) Axial ratio of high-band.

Fig. 2 (a) shows S_{11} characteristic of the proposed antenna. Center frequencies of low-band and high-band are 1.992GHz and 2.645GHz, respectively. Table 2 shows -10dB bandwidth of S_{11} characteristic for the proposed antenna. Fig. 2 (b) shows impedance loci of the proposed antenna. We can see that the input port is well matched to 50Ω for low-band and high-band of interest. Fig. 2 (c) and (d) show axial ratio characteristics of low-band and high-band. Axial ratios of low-band at 2.005GHz and high-band 2.645GHz are 1.02dB and 2.37dB, respectively.

Table 2. -10dB bandwidth of S_{11} .

Low-band		High-band	
Center Frequency	Bandwidth	Center frequency	Bandwidth
1.992GHz	56MHz	2.645GHz	60MHz

Fig. 3 shows simulated radiation patterns of the proposed antenna. Simulation results for the maximum gain of the dual-band antenna are about 9.12dBi and 7.77dBi. And half-power beamwidth at 2.005GHz and 2.645GHz are 66° and 70° , respectively as shown in Fig. 3.

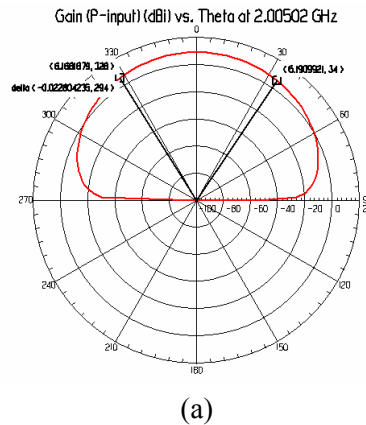

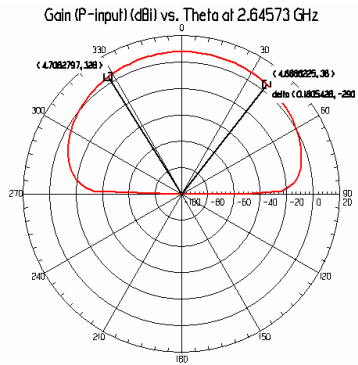

(b)

Fig. 3. Radiation patterns for the proposed antenna.

(a) Radiation pattern in $\Phi=0$ plane at 2.005GHz,

(b) Radiation pattern in $\Phi=0$ plane at 2.645GHz.

4. Conclusions

Design of single-feed CP microstrip antenna using slotted triangular patch with dual-band characteristic has been proposed and simulation results are presented. The dual-band operating characteristic of the proposed single-feed multiple slotted triangular microstrip antenna shows the same polarization direction characteristic and similar radiation characteristics.

Simulation results of the proposed antenna show proper electrical characteristics for dual band CP operations. Simulation result for impedance loci shows that the input port is well matched to 50Ω for low-band and high-band of interest. Axial ratios, maximum gains and half-power beamwidths are 1.02dB, 9.12dBi, 66° for low-band at 2.005GHz and 2.37dB, 7.77dBi, 70° for high-band at 2.645GHz, respectively.

References

- [1] W. G. Yang, D.S. Kim, J.A. Ju, and D.S. Kim, "Experimental results of patch antenna for wireless local loop," *Proc. of ICEIC '98*, pp.II-326-II-329, Aug. 1998.
- [2] C.A. Balanis, *Antenna Theory*, John Wiley & Sons, 1997.
- [3] K.L. Wong and J. Y. Wu, "A circularly polarized small-size microstrip antenna with a cross slot," *IEEE Trans. Antennas Propagat.*, vol. 44, pp. 1399-1301, Oct. 1996.
- [4] Jui-Han Lu, Chia-Luan Tang, and Kin-Lu Wong, "Single-feed slotted equilateral-triangular microstrip antenna for circular polarization," *IEEE Trans. Antennas Propagat.*, vol. 47, no. 7, pp. 1174-1178, July 1999.
- [5] R. Garg, *Microstrip Antenna Design Handbook*, Artech House, 2001.
- [6] S. Maci, G. Biffi Gentili, P. Piazzesi, and C. Salvador, "Dual-band slot-loaded patch antenna," *IEE Proc. Microwave Antennas Propag.*, vol. 142, pp.225-232, 1995.