

WIDEBAND CIRCULARLY POLARIZED ARRAY ANTENNA WITH SEQUENTIAL ROTATIONS AND PHASE SHIFT OF ELEMENTS

Tasuku TESHIRUGI, Masato TANAKA, Wataru CHUJO
 Radio Research Laboratories, RTOPT
 Nukui-Kitamachi 4-2-1, Koganei-shi, Tokyo, 184 JAPAN

1. INTRODUCTION

Circularly polarized microstrip array antennas have been widely used as phased arrays, mobile antennas, satellite antennas, and receiving antennas for direct satellite broadcasting, due to their thin and compact structures.

The problem, however, is that frequency characteristics of polarization and impedance of microstrip arrays are narrow. Several broadband techniques for circularly polarized microstrip antenna or array are reported(1),(2),(3).

This paper proposes a new composition of array antenna which has good circular polarization and low VSWR over the wide frequency band in spite of use of narrow band elements and describe the results of the verification experiment.

2. GENERATION OF WIDEBAND CIRCULAR POLARIZATION BY PROVIDING SEQUENTIAL ROTATIONS AND PHASE SHIFTS TO ELEMENTS

Let's consider a n -element planar array antenna as shown in Fig.1. In the following analysis, it is assumed that all elements are the same, and the mutual coupling can be neglected.

The n -th element is located at an arbitrary position but with orientation angle of

$$\phi_n = p(n-1)\pi/h \text{ (rad.)}, \quad (1)$$

where p is an integer and $1 \leq p \leq N-1$, with respect to the first element, say #1, and is fed with a differential phase shift of ϕ_n . In other words, each element n is provided sequential rotation and phase shift. Therefore, for convenience, we call it a sequential array. We assume that the polarization of electric field radiated by #1 element in the boresight direction is elliptical and expressed as

$$E_1 = aU_1 + jbV_1, \quad (2)$$

where U_1 and V_1 are orthogonal unit vectors, and a, b are the amplitude of the components. Then, the boresight field radiated by the n -th element E_n becomes

$$E_n = [(a \cos \phi_n - jb \sin \phi_n)U_1 + (a \sin \phi_n + jb \cos \phi_n)V_1] \exp(j\phi_n), \quad (3)$$

Using the following relations:

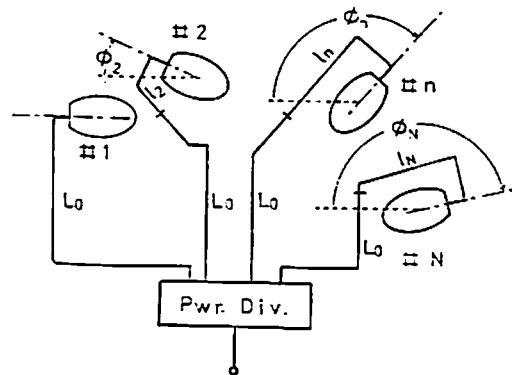

$$L_n = L_0 + l_n$$

$$k_0 l_n = \phi_n = (n-1)p\pi/N$$

$$k_0 = 2\pi f_0 \sqrt{\epsilon\mu}$$

Fig.1. Configuration of a sequential array

$$\sum_{n=1}^N \cos^2 \psi_n = \sum_{n=1}^N \sin^2 \psi_n = N/2, \quad (4)$$

$$\sum_{n=1}^N \cos 2\psi_n = \sum_{n=1}^N \sin 2\psi_n = 0, \quad (5)$$

we obtain the total boresight field E radiated by the array, such as

$$E = \sum_{n=1}^N E_n = \frac{(a+b)}{2} N(U_1 + jV_1). \quad (6)$$

This means that the sequential array radiates perfect circular polarized wave in the boresight direction independently of the polarization of the element. In general, because microstrip antenna is narrowband, polarization becomes rapidly as frequency changes from its center. But, the sequential array can greatly reduce the cross polarization, even at off-center frequency. Consequently, we can get a wideband circularly polarized microstrip array.

Fig. 2 shows the improvement factor of XPD, η , the ratio of the XPD of the array to the XPD of the element. From this figure, it is clear that XPD is improved as N increases, and the case of $p=1$ is the best.

Next, we consider VSWR at the input terminal of a sequential array. In the Fig.1, we assume that the input power is equally divided to each element, so let the amplitude of the input voltage to each element be V_0 . Owing to the differential path length of each feed line, the reflected waves from the n -th element have a differential phase shift of $2\psi_n$. Therefore, if all reflection coefficients of the elements are the same, the sum of the total reflected wave V_r returning to the input terminal of the array becomes

$$V_r = V_0 \sum_{n=1}^N \exp(j2\psi_n) = 0. \quad (7)$$

From the above discussion, it can be seen that the sequential array provides not only perfect circular polarization in the boresight direction but also, no reflection at the input terminal.

3. OFF-AXIS RADIATION OF PLANAR SEQUENTIAL ARRAY

In this section we consider a $M \times N$ planar sequential array in which the elements are arranged on rectangular lattices as shown in Fig.3. In this array, each column and each row are the sequential linear arrays. Let the differential phase shift and rotation to be given to the (m,n) -th element be ψ_{mn} . The radiation pattern of the element in the E-plane and H-plane are expressed by $E_p(\theta)$ and $H_p(\theta)$, respectively, and let p the

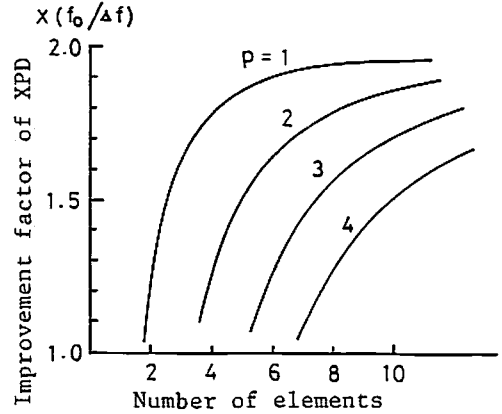

Fig.2. Improvement factor of XPD

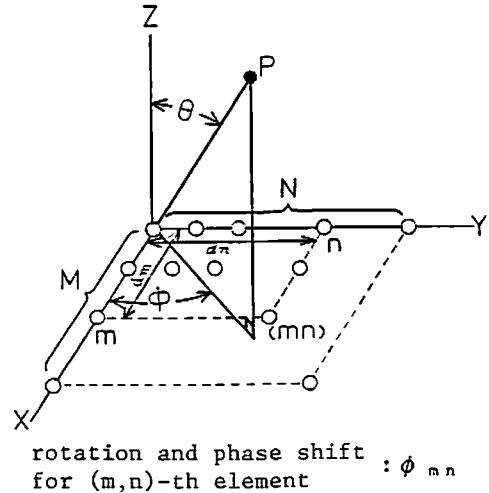

Fig.3. Geometry of a planar sequential array

complex excitation factor for the quadrature components be α ($\alpha=\pm 1$ means perfect circular polarization). We can obtain the expression of the radiation pattern for arbitrary angular cut plane. Particularly, in the $\phi=0$ (X-Z plane), using the sequential conditions, one has

$$E(\theta, 0) = \frac{(1+\alpha)}{2} M \left(\sum_{n=1}^M e^{jk d_n \sin \theta} \right) (E_p(\theta) e_\theta + j H_p(\theta) e_\phi), \quad (8)$$

where e_θ and e_ϕ are unit vectors. Similarly, in the plane $\phi=\pi/2$,

$$E(\theta, \pi/2) = j \frac{1+\alpha}{2} M \left(\sum_{n=1}^M e^{jk d_n \sin \theta} \right) (E_p(\theta) e_\theta + j H_p(\theta) e_\phi). \quad (9)$$

Therefore, in the two principal planes, within the angular region where $E(\theta)=H(\theta)$ holds, the array radiates circular polarized wave independently of the polarization of the element. In ordinary microstrip antennas, the patterns in the E- and H-planes almost agree up to considerable angular region, so the sequential array composed of these element has excellent polarization isolation over the wide angle.

4. EXPERIMENTAL RESULTS

In order to verify the principle of the sequential array, some basic experiments have been carried out.

The test array used are two 8-element arrays. One is a sequential, and the other is a conventional arrays as shown in Fig.4. All elements are the same microstrip circular patches which have small notches and is excited by one-point-backside feeding(3). The material of the substrate is glass cloth PTFE and its ϵ_r is 2.6 and the thickness is 4 mm.

Fig. 5 and 6 show the axial ratio and VSWR of these arrays. From these figures, it is clear that the sequential array has much more wideband characteristics of polarization and impedance than the conventional array. For example, 3 dB axial ratio bandwidth of the sequential array exceeds 14% and this is about 15 times of the conventional array, while

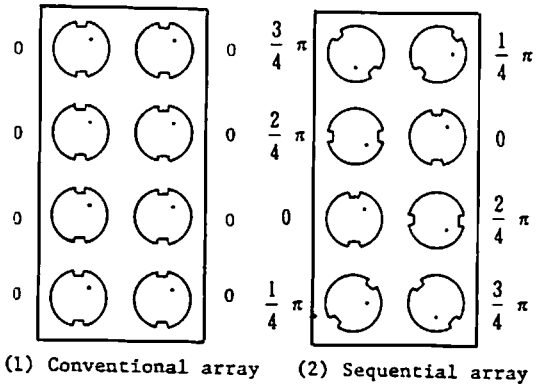

Fig.4. Arrangement of elements for two test arrays

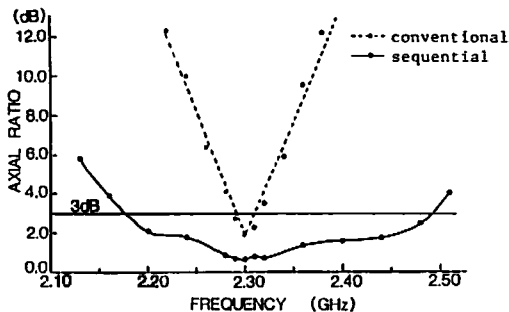

Fig.5. Measured axial ratio vs. frequency

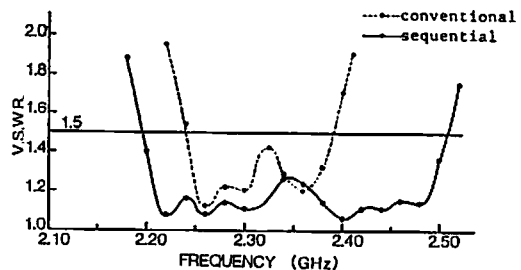

Fig.6. Measured V.S.W.R. vs. frequency

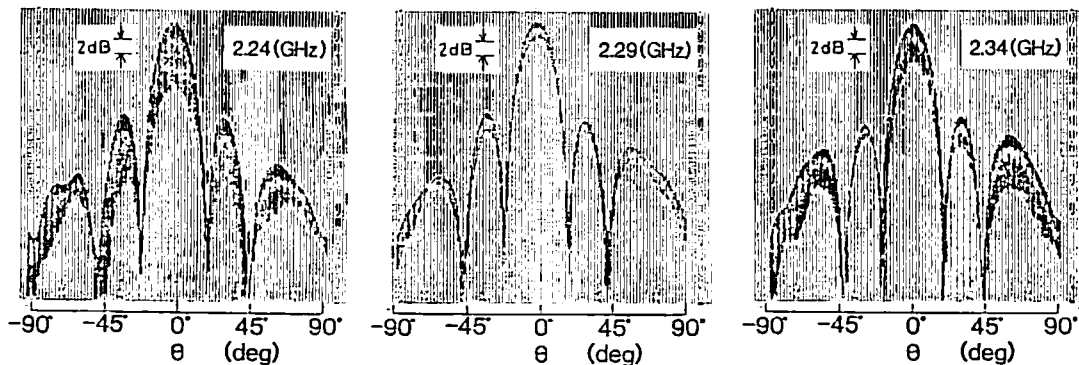

Fig.7. Radiation patterns of the conventional array

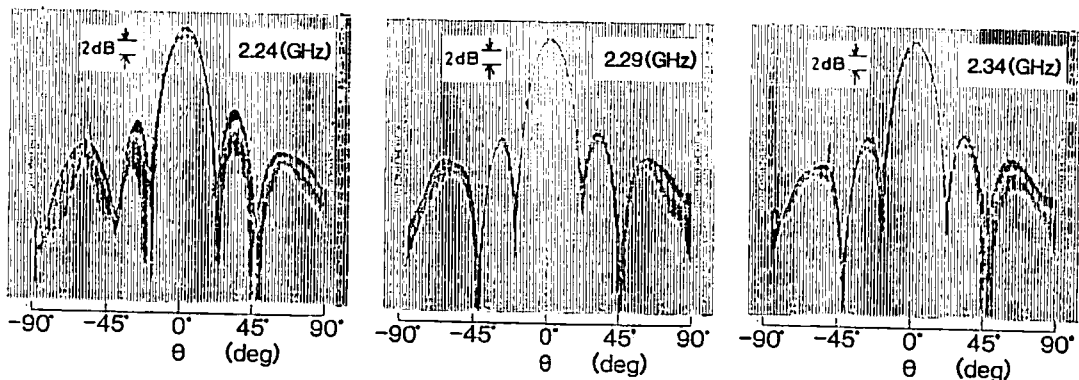

Fig.8. Radiation patterns of the sequential array

1.5 VSWR width is 13.7% and about twice as that of the conventional array.

Finally, the comparison of the radiation patterns is shown. Fig. 7 and Fig. 8 show the radiation patterns of the conventional array and the sequential array, respectively. It can be seen that the polarization of the conventional array deteriorates except at the center frequency, while the sequential array maintains good circular polarization over the range from 2.24 GHz to 2.34 GHz.

REFERENCES

- (1) K. R. Carver et al. "Microstrip antenna technology", IEEE Trans. AP-29, No.1 (Jan. 1981)
- (2) Y. Suzuki et al. "Expanding the frequency bandwidth of a microstrip antenna", IEEE AP-S Int. Symp. Digest vol.1 p 336 (June 1981)
- (3) H. Haneishi et al. "A broadband microstrip array composed of single feed type circularly polarized microstrip antennas", IEEE AP-S Int. Symp. Digest pp.160-163 (May 1982)