

T antenna for whole PCB structure

Toshiaki YANO, Nobuhiro KUGA, and Hiroyuki ARAI
 Faculty of Engineering, Yokohama National University
 79-5 Tokiwadai, Hodogaya-ku, Yokohama 240-8501, Japan.
 E-mail: yano@arailab.dnj.ynu.ac.jp

1 Introduction

In direction of arrival(DOA) estimation systems using omni-directional antenna array, manufacturing error such as element-size or element-spacing deteriorates estimation accuracy [1][2]. The problem is more serious in higher frequency band such as 5GHz and above. In consequent, the antenna structure minimizing manufacturing error is required for DOA estimation systems, which is realized by using printed circuit technology. Mutual coupling between elements also affects on DOA estimation accuracy. Although several calibration techniques with software compensating for the effect have been proposed, it is not effective for actual input characteristics of experimental antenna. Therefore, full-printed structure using printed circuit boards(PCBs) would be also attractive from the viewpoint of easy tunability, which leads to bandwidth enhancement.

On the other hand, the T antenna is suitable for a DOA-array component in terms of its omni-directional pattern and reduced antenna height in its structure. Several techniques for bandwidth enhancement were proposed such as parasitic element scheme [3] and a scheme utilizing the parallel resonance mode due to additional branch wires [4]. However, their productivity and tunability should be improved, and undesired radiation from feeding coaxial lines is also disadvantageous.

In this paper, a novel T antenna suitable for fully PCB structure with easy tunability is proposed, and its fundamental concept and design method are described. A bandwidth enhancement technique by using parallel placed T elements is also presented. Antenna characteristics are mainly examined numerically by using FDTD method[5].

2 Antenna Configuration

Fig. 1 shows an antenna configuration. The T element is composed of a horizontal strip #1 and a vertical strip-line with shorted-plate which acts as a short-ended inductive stub. These are printed on the PCB substrate #A. The vertical strip element has two metal strips with the different width of W_1 and W_2 . The bottom PCB substrate #B is composed of a rectangular patch with $W_B \times W_B$ and ground plane. The patch #2 is designed to act as a capacitor C. The PCB #A is placed perpendicularly on the PCB #B, in which one of the vertical strips is connected to the patch #2 and another is grounded via the substrate #B. In the proposed structure, it is possible to incorporate the feeding circuits on the PCB #B, which enables to reduce the undesired radiation and complexity in feeding cable connection circuits.

The proposed antenna is decomposed into two models as shown in Fig. 2. Model-1 represents the even current mode, which is equivalent to a printed T antenna with a thick vertical element. The current flows in phase on #3 and #4, and affects on the radiation resistance which is determined by the fractional plate-width W_1/W_2 [6]. Model-2 represents the odd current-mode, which is composed of the patch #2 and the parallel plates acting as capacitive and inductive stub, respectively.

3 Antenna Design and Characteristics

Model-1 is represented by a series-LCR equivalent circuit resonates when the electrical length of $h_{T1} + W_T/2$ becomes approximately quarter wave-length. On the other hand, Model-2 which is represented by a parallel-LCR circuit resonates when the susceptance due to the inductive stub is cancelled out by one due to the capacitive stub. After designing of each decomposed antenna, they are combined as the proposed antenna resonating around the designed frequency. Deducing the accurate equivalent circuit for the combined antenna have not been completed and is left as a future problem.

Fig. 3 shows calculated input admittance of the proposed antenna, where the characteristics of the decomposed models are also presented. The dielectric constant ϵ_{r1} , ϵ_{r2} is assumed as 2.6. In the fig. 3(a),

it is confirmed that the radiation conductance is mainly produced by the Model-1 while Model-2 has no radiation conductance. Fig. 3(b) shows the susceptance of them, which shows that the combined antenna resonates at 900MHz while the decomposed antennas are designed at 895MHz. The error in frequency is small and negligible from the practical viewpoint. Total susceptance around resonance frequency is reduced in the combined antenna, which may contribute to bandwidth enhancement.

Fig. 4 shows input characteristics of the combined antenna where the system impedance is assumed as 50Ω . The characteristics are calculated and measured for $\epsilon_{r1} = \epsilon_{r2} = 2.6$. Good agreement with small frequency error is obtained between them. The fractional bandwidth ($S_{11} \leq -10\text{dB}$) of about 6% is obtained for the calculation and measurement with $\epsilon_{r1} = \epsilon_{r2} = 2.6$, which is relatively narrow for actual usage. As a reference, characteristics of the air-loaded antenna ($\epsilon_{r1} = \epsilon_{r2} = 1.0$) is also calculated and are shown as a broken line in the figure. The fractional bandwidth of about 6% is also obtained. Therefore, a bandwidth enhancement technique is required. It will be presented in next section.

Fig. 5 shows the radiation characteristics of the proposed antenna which are measured at 890MHz. In measurement, circular conductor plate with the radius of 500mm is used as a ground plane. The pattern is normalized by the maximum at each observation plane. In the XY-Plane, good uniformity with the small deviation of 0.3dB is obtained without the cross polarized wave. In the YZ and ZX-Plane, the pattern with the z-axis null is obtained without cross polarized radiation.

4 Bandwidth Enhancement by Parallel T elements Structure

This section presents a bandwidth enhancement technique with simple antenna structure. Fig. 6 shows an antenna configuration of proposed antenna. Two antenna substrates #A1 and #A2 are mounted perpendicularly on the substrate #B, and with the rotational symmetry for the z-axis. The spacing between the vertical substrate is d . The design principle described in the previous section can be applied to this antenna. The calculated S_{11} characteristics are shown in Fig. 6(b), where the dielectric constant is assumed as $\epsilon_{r1} = \epsilon_{r2} = 1.0$ to simply confirm the validity of the proposed concept. The antenna here has same height with one in the previous section. The impedance bandwidth is successfully enhanced up to about 20% with twin-peak characteristics. This concept can be applicable to the dielectric substrate such as $\epsilon_{r1} = \epsilon_{r2} = 2.6$ and above.

5 Conclusion

In this paper, we presented the full-printed T antenna which consists of horizontal and vertical PCB substrates, and of which fundamental concept and design method. In consequence, proposed antenna structure reduced manufacturing error. We calculated and measured the input characteristics and radiation pattern. It was also confirmed that proposed antenna had an omni-directional pattern at 890MHz. Without changing the antenna height, impedance bandwidth was enhanced by parallel placed printed T elements. This antenna had fractional bandwidth of about 20%. Future work is deducing the accurate equivalent circuit for the proposed antenna.

References

- [1] Y. INOUE and H. ARAI, "Effect of mutual coupling and manufactural error of array for DOA estimation of ESPRIT algorithm," IEICE Trans., vol. J86-B, No. 10, pp. 2145-2152, Oct. 2003.
- [2] T. ARAI, et al., "On calibration of superresolution array using known sources," IEICE Trans., vol. J86-B, No. 3, pp. 527-535, Mar. 2003.
- [3] N. KUGA, et al., "Bandwidth enhancement of T-monopole antenna by using parasitic inverted-L elements," IEICE Trans., vol. J86-B, No. 9, pp. 2011-2015, Sep. 2003.
- [4] S. SEKINE, et al., "Design method for a broadband inverted-F antenna by parallel resonance mode," IEICE Trans., vol. J86-B, No. 9, pp. 1806-1815, Sep. 2003.
- [5] CST Technology, MW-Studio User's Manual
- [6] H. D. Foltz, et al., "Disk-loaded monopoles with parallel strip elements," IEEE Trans. Antennas Propagat., vol. AP-46, no.12, pp.1894-1896, Dec. 1988.

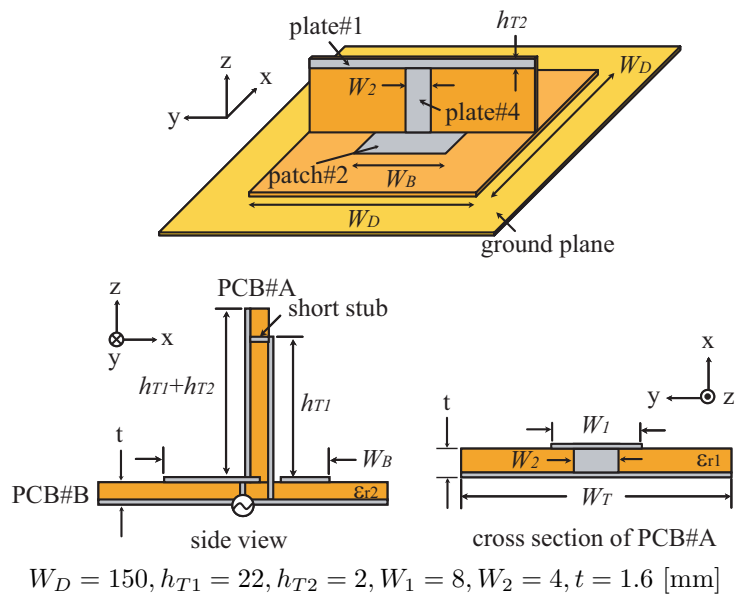

Figure 1: Antenna configuration

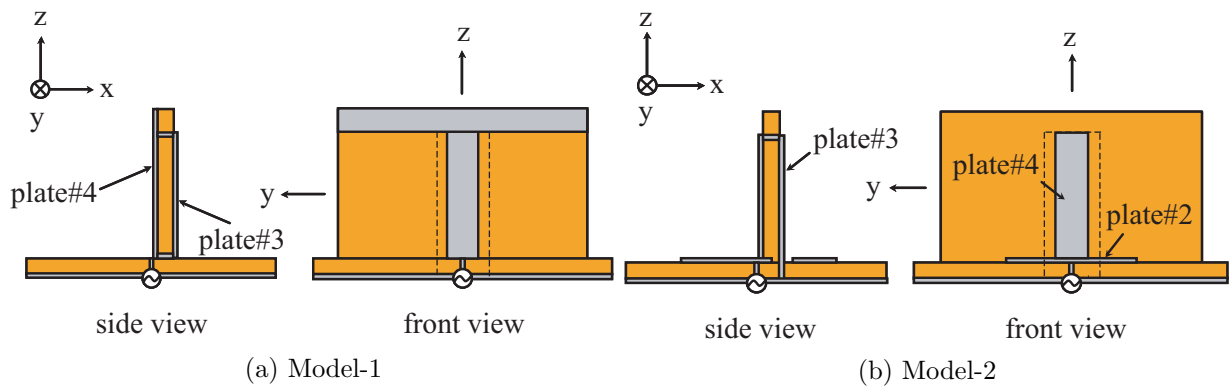

Figure 2: Antenna component model

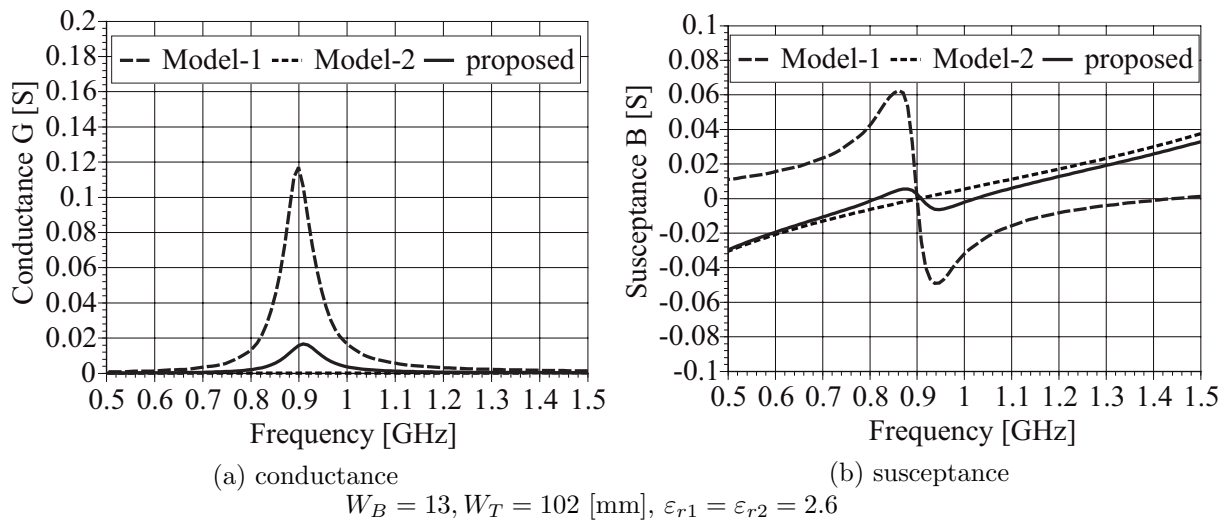
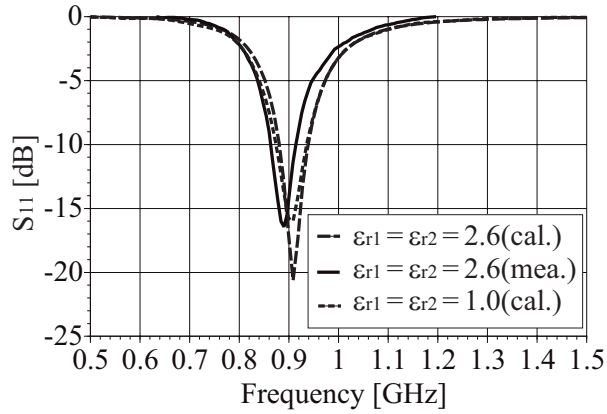

Figure 3: Input admittance characteristics



$\epsilon_{r1} = \epsilon_{r2} = 2.6 : W_B = 13, W_T = 102$
 $\epsilon_{r1} = \epsilon_{r2} = 1.0 : W_B = 22, W_T = 115$ [mm]

Figure 4: Input characteristics

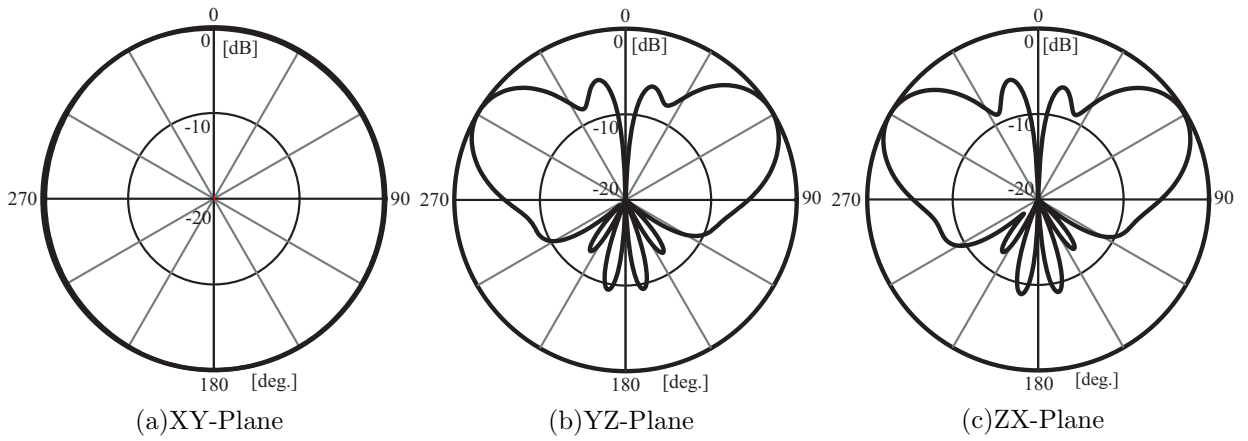

Figure 5: Radiation pattern at 890MHz(measurement) : $\epsilon_{r1} = \epsilon_{r2} = 2.6$

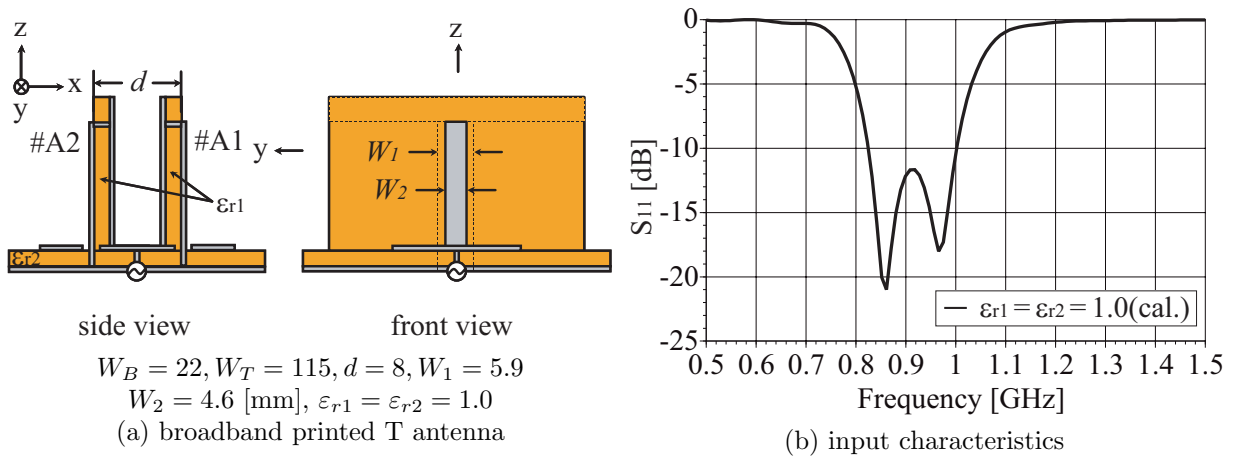

Figure 6: Antenna configuration and input characteristics