

Deformed Antenna Pattern Compensation Technique for Multi-beam Antennas for Broadband and Scalable Mobile Communications Satellite

Yoshinori SUZUKI ¹, Satoshi HARADA ², Kiyoshi KOBAYASHI ³, Masazumi UEBA ⁴

¹ NTT Access Network Service Systems Laboratories, NTT Corporation

1-1 Hikarinooka, Yokosuka, Kanagawa, 239-0847 Japan, suzuki.yoshinori@lab.ntt.co.jp

² NTT Access Network Service Systems Laboratories, NTT Corporation

1-1 Hikarinooka, Yokosuka, Kanagawa, 239-0847 Japan, harada.satoshi@lab.ntt.co.jp

³ NTT Access Network Service Systems Laboratories, NTT Corporation

1-1 Hikarinooka, Yokosuka, Kanagawa, 239-0847 Japan, kobayashi.kiyoshi@lab.ntt.co.jp

⁴ NTT Access Network Service Systems Laboratories, NTT Corporation

1-1 Hikarinooka, Yokosuka, Kanagawa, 239-0847 Japan, ueba.masazumi@lab.ntt.co.jp

Abstract

To create a next-generation mobile satellite communication system that offers large communication capacity, the onboard antenna system must be a multi-beam system consisting of a light weight 20-m class reflector and a light weight 100-beam class antenna feed system. We clarify that the antenna gain decrease created by the reflector surface distortion in orbit is relatively large. This paper presents a deformed antenna pattern compensation method that uses the minimum circuits amount. Validity of the proposed method is confirmed by antenna pattern calculations and experiments on a fabricated array-fed reflector antenna.

1. INTRODUCTION

Mobile satellite communications systems have been rapidly moving toward the broadband service. We previously reported the concept of an S-band next generation mobile satellite communication system for domestic service. We estimate that the total amount of traffic carried by such systems in Japan will be 1 Gbps; our intention is to realize a cost-effective system in S-band as a 1-ton-class geostationary satellite [1], [2].

The required capacity of 1 Gbps can be achieved by employing a multi-beam system that allows high antenna gain beams and extremely high levels of frequency reuse. Moreover, it is required that the RF power resource allocated to each beam vary to match the beam's traffic.

Two major technologies are important in achieving the proposed system. The first one is an ultra light-weight large antenna reflector, whose aperture diameter is about 20 m. The second is a light-weight 100-beam class antenna feed system. We have studied the technologies available to satisfy such requirements. The electric performance and function of the

antenna designed using these technologies are described in previous reports [3], [4].

Our prior studies identified the problem that the antenna patterns are deformed by the reflector surface distortion in orbit and antenna gain decrease of the target area is relatively large. The deformed antenna patterns can not be compensated by conventional mechanical methods, because the reflector surface distortion fails to keep the relative positions of the formed beams. In array-fed reflector multi-beam antennas, since each beam is formed by an appropriate exciting weight for each target area, the deformed antenna patterns can be compensated by electrical method. However, a very large number of variable phase-shifters is needed to compensate the deformed antenna patterns.

This paper presents a novel electrical approach to the compensation of deformed antenna patterns. The compensation function is realized with the minimum of additional devices. To achieve the proposed method, we propose here two important technologies: highly precise detection of beam pointing errors and a method of determining phase shift compensation value. The validity of the proposed methods is confirmed by antenna pattern calculations and experiments on a fabricated array-fed reflector antenna.

2. REQUIREMENTS FOR ONBOARD ANTENNA SYSTEMS AND DESIGNED ANTENNA

As described above, our aim is to realize an S-band 1-ton-class geostationary satellite that offers up to 1 Gbps. This is 30 times the capacity of the current mobile communication satellites.

Achieving 1 Gbps capacity in the 30 MHz bandwidth allocated to MSS (Mobile Satellite Service) in S-band requires frequency reuse in excess of 20 times. Figure 1

shows an example of beam allocation for the system. Current S-band service coverage is covered by 69 beams. Each beam offers at least 43.5dBi at its edge of coverage (EOC). The onboard antenna system must allocate RF power to each beam according to the beam's traffic.

To meet the system requirements, we studied an onboard multi-beam reflector antenna [3], [4]. Designed antenna was an off-focal type array-fed reflector antenna whose configuration is shown in Fig. 2(a). Fig. 2(b) shows an image of ultra-light weight large reflector which consists of a large scale cable network system and rib structure with tendons and suffers from large deformation [3]. The antenna parameters are shown in Table 1. Since the antenna feed system must be lightweight while achieving high antenna gain and highly RF power distribution flexibility between beams, it employs two of our techniques [4]. The first one is to apply beam group concept. It set up beam groups; in each group, all beams are excited using the same amplitude weight. This improves antenna gain over the entire coverage area compared with the conventional array-fed reflector antenna and realizes RF power distribution flexibility between beams. The 2nd technique is a beam-forming method that combines beams from different beam-groups so as to improve RF power distribution flexibility between beams. The antenna feed system that uses our techniques is much lighter than conventional multi-beam antenna feed systems.

Calculated antenna patterns of the North-West-Edge, the South-West-Edge and the South-East-Edge are shown in Figure 1. These beams' EOC gains are 44.12, 44.14 and 43.91dBi, respectively. We confirmed by calculations that the antenna gain requirements were satisfied.

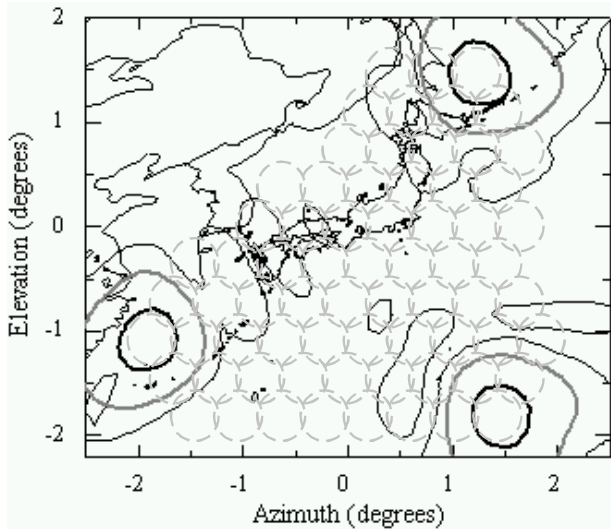
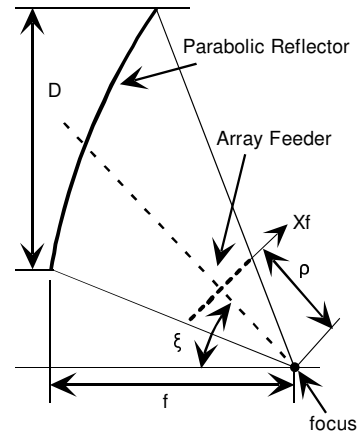
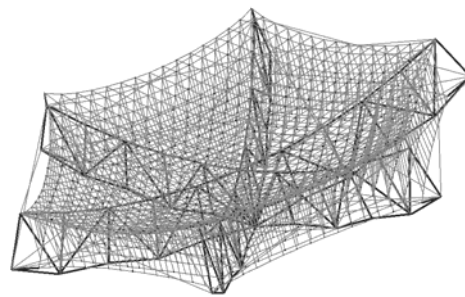

Fig. 1: Beam Allocation and Calculated North-East edge, South-East edge and South-West edge Antenna Patterns (Contours: -2dB, -10dB and -20dB below peak)



(a): Antenna Configuration



(b): An Image of Reflector

Fig. 2: Designed Array-fed Multi-beam Reflector Antenna

TABLE 1: DESIGNED ANTENNA PARAMETERS

Frequency	S-band
Aperture diameter : D (m)	19.0
Focal length : f (m)	13.3
Defocus length : ρ (m)	1.2
Offset angle : ξ (degrees)	43.5
Feed element	Microstrip patch
Feed element spacing (mm)	120
Number of elements	64
Number of beams	69

3. DEFORMED ANTENNA PATTERN BY REFLECTOR SURFACE DISTORTION IN ORBIT

The antenna patterns are degraded by satellite attitude fluctuation, reflector misalignment, reflector surface distortion, and others. These factors generally shift entire antenna patterns while maintaining the relative positions of the beams. Such displacement can be compensated by conventional mechanical methods. Thermal distortion of reflector surface in eclipse, however, yields defocusing and curvature variation of the reflector, antenna patterns are either expanded or shrunk. The relative positions of the formed beams are not kept. The deformed antenna patterns by 20-m class reflector surface distortion are really significant in the service area edge beams.

We show by calculations that the impact of surface distortion is significant. To model the thermal shrinkage surface that should be allowed for, we assumed that the focus of the reflector shifted by 100mm away from its design position. Calculated antenna patterns for the before and after deformed by reflector surface distortion are shown in Figure 3. The antenna patterns are for the North-East-Edge, the South-West-Edge and the South-East-Edge; the pointing errors are quite obvious. These beams' EOC gains of each target area are 42.16 dBi, 43.00dBi and 42.82dBi, respectively. These changes break the antenna gain requirements relatively large and force the development of a new compensation method.

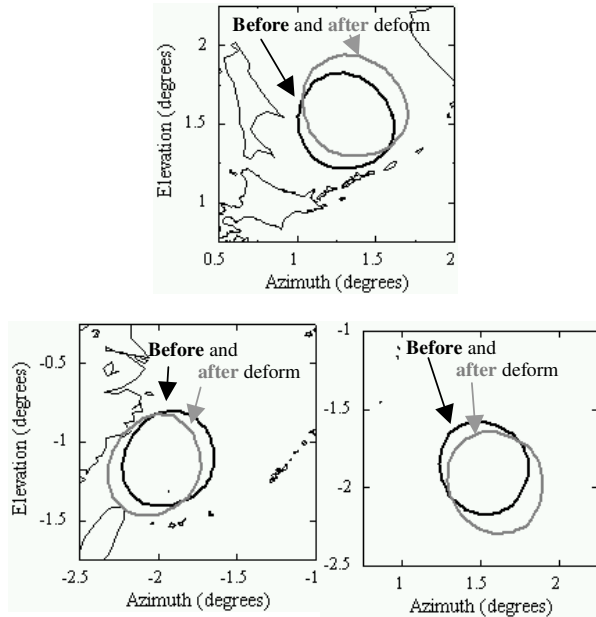

Fig. 3: Calculated North-East edge, South-West and South-East edge Antenna Patterns (Contours: -2dB below peak of before and after deformed by reflector surface distortion)

4. DEFORMED ANTENNA PATTERN COMPENSATION METHOD

A. Concept of Deformed Antenna Pattern Compensation Method

In array-fed reflector multi-beam antennas, since each beam is formed by an appropriate exciting weight for each target area, deformed antenna patterns can be compensated by electrical method. However, it is necessary to adjust the exciting weight of each beam independently and a very large number of variable phase-shifters must be needed. We propose here a novel antenna pattern compensation method. The concept is to achieve the compensation function with the minimum of additional devices. Figure 4 shows a block diagram of an array-fed reflector multi-beam antenna that uses the deformed antenna pattern compensation method. The

added devices are variable phase-shifters connected to each feed element, phase-shift controller, and pointing error detector.

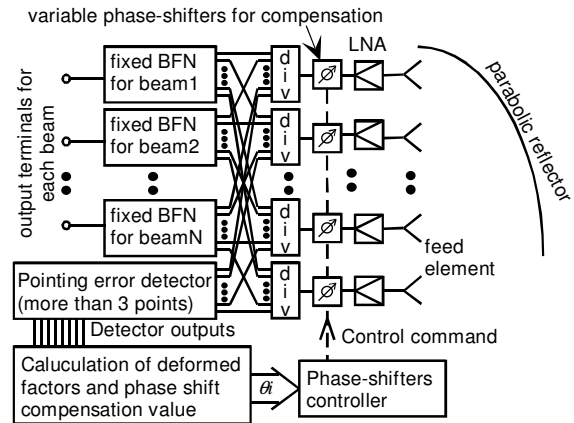

Fig. 4: Block Diagram of Array-fed Reflector Multi-beam Antenna with Deformed Antenna Pattern Compensation Function

In order to compensate the gross deformation of all antenna patterns with common phase-shifters, a method for determining each phase shift compensation value is a very important. We assume that there are two characteristic factors and calculate phase compensation for each factor. The first one, defined as “directivity shift factor”, indicates the whole movement of the antenna patterns; the relative positions of the beams are maintained. The second factor, defined as “scale fluctuation factor”, indicates the expansion or shrinkage of the entire antenna patterns.

These deformed factors are extracted from beam pointing error. Since the directivity shift factor consists of azimuth and elevation coefficients and the scale fluctuation factor has one coefficient, we have to need more than three pointing error detection points. Figure 5 shows our deformed antenna patterns compensation flow. The compensation phase shifters are then controlled according to the calculated factors. Two technologies form the heart of the proposed method. The first one is a method of determining phase shift compensation value. The second is the highly precise detection of beam pointing errors. The details of the two technologies are described below.

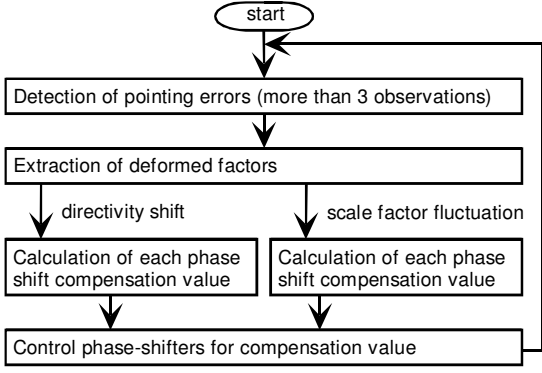

Fig. 5: Proposed Deformed Antenna Patterns Compensation Flow

B. Method of Determining Phase Compensation Values

To compensate the deformed antenna patterns with common phase-shifters, we calculate “directivity shift factor; $\mathbf{D} = (\delta_{az}, \delta_{el})$ ” and “scale fluctuation factor; S ” using detected pointing error signals at more than three observations. Figure 6 shows the concept of using the control phase to handle each deformation factor. In terms of the directivity shift factor, the phase-shift values that yield the virtual inclination of the aperture of the array feeder are determined. The phase compensation values for this factor of each feed element θ_{d_i} is given as follows,

$$\theta_{d_i} = (\alpha \cdot \delta_{az} + \beta \cdot \delta_{el}) (\mathbf{r}_i - \mathbf{r}_0)$$

where δ_{az} and δ_{el} indicate the directivity shift of azimuth and elevation angle, \mathbf{r}_i and \mathbf{r}_0 indicate a i -th feed element position and a center position of the feed array, α and β are coefficient, respectively. In terms of the scale fluctuation factor, the phase-shift values that yield a virtual curvature of the aperture are determined. The phase compensation values for this factor of each feed element θ_{s_i} is given as follows,

$$\theta_{s_i} = \gamma \{ |\mathbf{r}_i - \mathbf{r}'_0(S)| - |\mathbf{r}_0 - \mathbf{r}'_0(S)| \}$$

where \mathbf{r}'_0 indicate an original point of the virtual aperture, γ is a coefficient, respectively. Then, the total phase shift compensation values of each feed element is given as follows,

$$\theta_i = \theta_{d_i} + \theta_{s_i}.$$

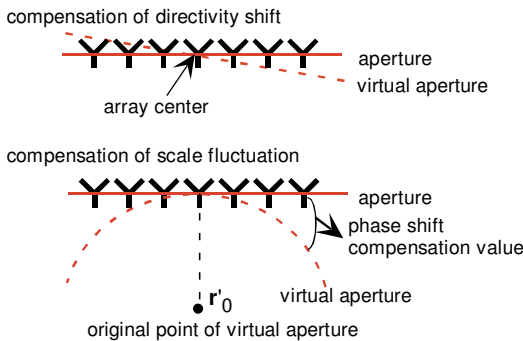

Fig. 6: Concept of the Control Phase-Shifting for Each Deformed Factors

C. Highly Precise Detection Method of Beam Pointing Errors

It is well known that the monopulse method offers a simple configuration and achieves very precise beam pointing error detection. It is used in tracking antennas and radar systems [5]. However, the monopulse method is not directly applicable to our antenna since it is structurally and electrically asymmetrical. In order to apply the monopulse method to our antenna, our proposal sets virtual axes to realize electrical symmetry.

Figure 7 shows our designed array feeder layout and virtual axes for the South-East edge beam. The virtual axes are set so that the received power level of each feed element group divided by the axes become the same. Figure 8 shows a block diagram of beam pointing errors detector. This obtains the azimuth and elevation pointing error signals as well as the formed beam signal.

Signal levels versus azimuth and elevation pointing error are calculated by the proposed technique. As an example, calculation result in the South-East-Edge beam is shown in Figure 9. The plots confirm the signal level has monotonous change within a range of over -0.3 to $+0.3$ degrees. It is large enough to detect expected beam pointing error.

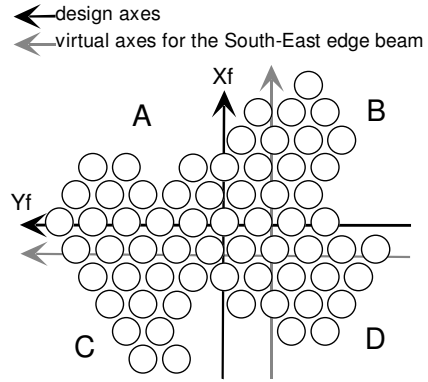

Fig. 7: Array Feeder Layout and Virtual Axes for the South-East Edge Beam

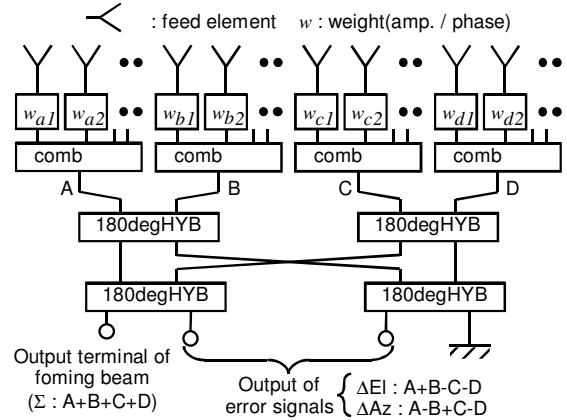

Fig. 8: Block Diagram of a Beam Pointing Error Detector

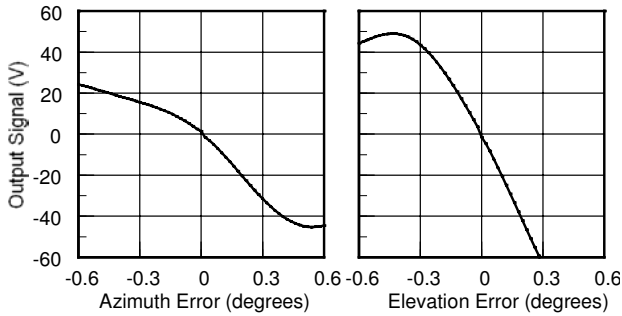

Fig. 9: Calculated Signal Levels versus Azimuth and Elevation Pointing Error in South-East Edge Beam

D. Simulation Result

Calculated antenna patterns for the before and compensated deformed reflector surfaces are shown in Figure 10. The antenna patterns of the North-East-Edge, South-West-Edge and the South-East-Edge are shown. Table 2 summarizes the calculated antenna patterns for the as-designed, deformed, and compensated reflector surfaces. It shows that our proposed method can adequately compensate the deformed antenna patterns to satisfying the antenna gain requirements.

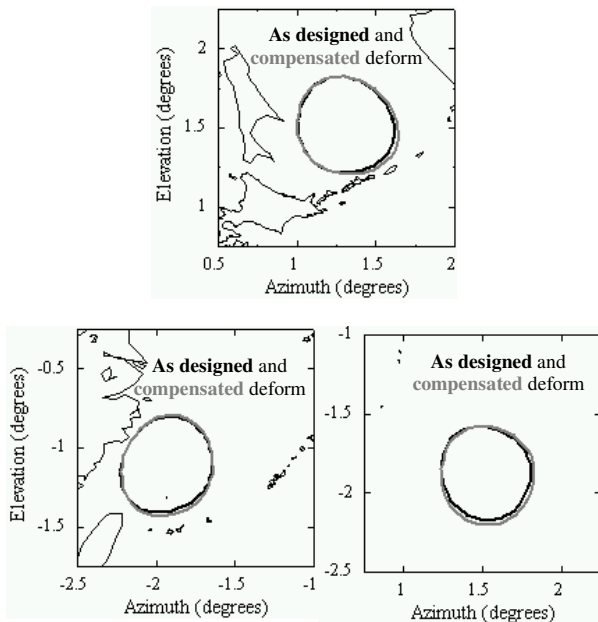

Fig. 10: Calculated North-East edge, South-West edge and South-East edge Antenna Patterns (Contours: -2dB below peak of as designed and compensated deformed antenna patterns)

TABLE 2: SUMMARY OF SIMULATION RESULT

Beam position	North East Edge	South East Edge	South West Edge
Requirement of EOC gain (dBi)	43.50		
As designed EOC gain (dBi)	44.12	44.14	43.91
Deformed EOC Gain (dBi)	42.16	42.82	43.00
Gain decrease (dB)	1.96	1.32	0.91
Pointing shift (degrees)	Az. : +0.108 El. : +0.063	Az. : -0.054 El. : +0.031	Az. : 0.000 El. : -0.025
Directivity shift (degrees)	Az. : +0.054, El. : +0.030		
Scale fluctuation	0.929		
Compensated EOC gain (dBi)	43.53	43.57	43.59
Compensation gain (dB)	1.37	0.75	0.59

5. EXPERIMENTAL VERIFICATION OF FUNDAMENTAL PERFORMANCE USING AN ARRAY-FED REFLECTOR MULTI-BEAM ANTENNA

A. Manufactured Array-fed Reflector Antenna

To verify the fundamental performance of the proposed antenna pattern compensation method, we fabricated an array-fed reflector multi-beam antenna; its block diagram is shown in Figure 4. An overview and design parameters are shown in Figure 11 and Table 3, respectively [6]. Three beams can be independently formed with the same elevation angle. Each beam is formed by a beam forming network which controls the amplitude and phase of each feed element.

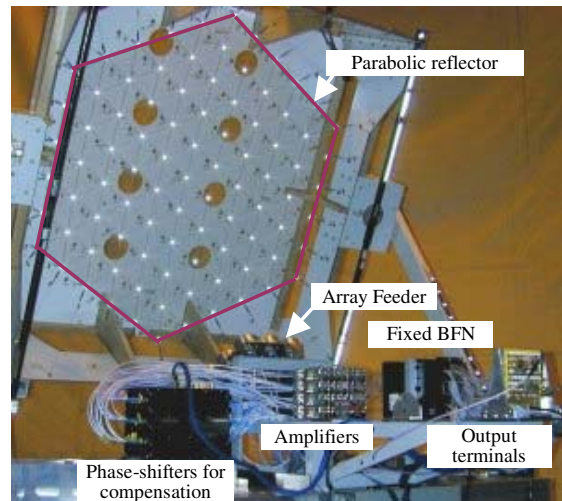

Fig. 11: Fabricated Array-fed Multi-beam Reflector Antenna

TABLE 3: FABRICATED ANTENNA PARAMETERS

Frequency (GHz)	2.6898
Aperture diameter : D (m)	1.40
Focal length : f (m)	1.15
Defocus length : ρ (m)	0.5
Offset angle : ξ (degrees)	45.0
Feed element	Helical with cup
Feed element spacing (mm)	90
Number of elements	19 (triangular lattice)
Number of beams	3

B. Experimental Verification Results

The experimental verification examined the two antenna deformations factors (directivity shift factor and scale fluctuation factor). The fabricated antenna subjected to far-field measurements. The fabricated antenna was set on a turntable in a semi-open type radio anechoic chamber about 1.6 Km from the transmission antenna.

The results are shown in Figure 12. Fig.12 (a) shows the compensation of the directivity shift factor. All antenna patterns were shifted in the same direction by the phase control. Fig.12 (b) shows the compensation of the scale fluctuation factor. All antenna patterns were basically scaled by the phase control. These plots confirm that the proposed deformed antenna pattern compensation method offers the fundamental functions needed.

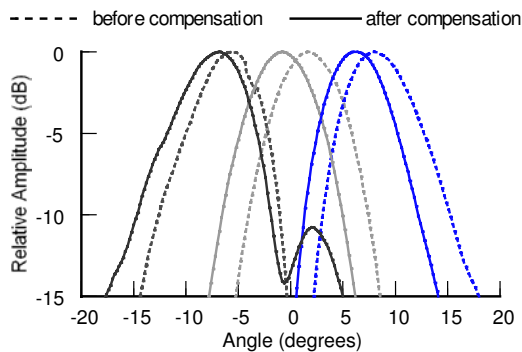

(a): Compensation of the Directivity Shift Factor

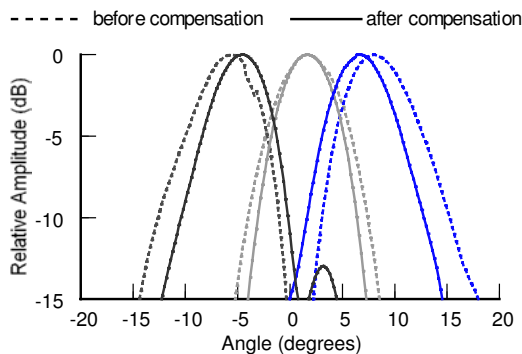

(b): Compensation of the Scale Fluctuation Factor

Fig. 12: Measured Antenna Patterns before and after Phase Control Compensation

6. CONCLUSIONS

We proposed a novel deformed antenna pattern compensation method that requires the minimum of additional devices. To realize the proposed method, we proposed two techniques: the highly precise detection of beam pointing errors and a method of determining the phase shift compensation values.

We calculated antenna patterns to confirm the validity of the proposed method. The results showed that our method can compensate antenna pattern deformation so that the antenna gain requirements are satisfied. The fundamental performance of the proposed method was experimentally verified using a fabricated antenna with three beams.

We intend to conduct more extensive experiments on the proposed method and further enhance its performance.

ACKNOWLEDGEMENT

This work is partially supported by The SCOPE (Strategic Information and Communications R&D Promotion Programme) by the Ministry of Internal Affairs and Communications.

REFERENCES

- [1] M. Ueba, K. Ohata, J. Mitsugi, and M. Umehira, "Broadband and Scalable Mobile Satellite Communication System for Future Access Networks," Proc. 22nd AIAA International Communications Satellite Systems Conference, 2004-3154, May 2004, Monterey, CA.
- [2] M. Ueba, K. Ohata, A. Meguro, and K. Kobayashi, "A Feasibility Study of Broadband and Scalable Mobile Satellite Communication System for Ubiquitous Networks," Proc. 23rd AIAA International Communications Satellite Systems Conference, I000214, Sep. 2005, Roma, Italy.
- [3] A. Meguro, S. Harada, and M. Ueba, "Structural Characteristics of an Ultra-light Large Antenna Reflector onboard Communication Satellite," 55th International Astronautical Congress, IAF-04-11., Sep., 2004, Vancouver, Canada.
- [4] Y. Suzuki, A. Meguro, and M. Ueba, "Phased-array Multi-beam Antenna Feeder with Beam-group Configuration for Broadband and Scalable Mobile Satellite Communication Systems," Proc. 23rd AIAA International Communications Satellite Systems Conference, I000150, Sep. 2005, Roma, Italy.
- [5] G. Maral and M. Bousquet, "Satellite Communications System," John Wiley & Sons, Ltd., 2001.
- [6] Y. Suzuki, S. Harada, A. Meguro, and M. Ueba, "Experimental verification of deformed antenna patterns compensation method for next generation mobile communication satellite antennas," IEICE Technical Report, SAT2006-6, pp.29-32, May 2006.