

# STATISTICAL CHARACTERIZATION OF INDOOR MIMO CHANNEL PROPERTIES AT 5.8GHZ IN THE OFFICE BUILDING

Noh-Gyoung Kang and Seong-Cheol Kim  
INMC, SoEE & CS, Seoul National University  
San 56-1, Shillim-dong, Kwanakku, Seoul, 151-744, Korea  
E-mail : sckim@maxwell.snu.ac.kr

## ABSTRACT

A wideband 4×4 MIMO (multiple-input multiple-output) channel sounding system has been developed to measure 16 Tx-Rx pair channels simultaneously using PN (pseudo noise) correlation method. Measurement campaign in the medium size office building with the developed channel sounding system is reported. Measured results are analyzed to compute channel parameters such as rms delay spread, mean excess delay, and their statistics. MIMO system capacity is also analyzed from measured channel impulse responses. Statistics of computed channel parameters can be used to develop empirical wideband MIMO channel models.

## I. INTRODUCTION

Next generation wireless communication system is expected to support data rate up to 1 Gbps. In order to implement such ultra broadband wireless communication system, high spectral efficiency will be required because the radio spectrum resource is limited. MIMO system has been extensively investigated as a promising candidate system to meet the high spectral efficiency requirement [1][2].

The channel capacity of MIMO system is much higher than that of the system with a single transmitting and receiving antenna. However, the channel capacity of MIMO systems is highly dependent on the MIMO channel properties [3][4]. Therefore, characterizing MIMO channel properties is of great importance for studying performance analysis of MIMO systems as well as designing MIMO systems with high spectral efficiency.

The 4×4 MIMO channel sounding system using the PN correlation method developed in this has capability to measure channel properties of 16 Tx-Rx pairs simultaneously, which is quite different from other channel sounding systems such as RUSK and PROPSound using switching

method. The measurement campaigns are carried out at the 5.8GHz band in 45 meter by 32 meter size and four-storied office building having atrium in the center. During measurements, the orientation and spacing of antennas, Tx and Rx locations and the antenna height are carefully chosen to consider possible next generation broadband wireless service. We show measured channel parameters such as rms delay spread, mean excess delay and their statistics using the measurement results.

The paper is organized as follows: In section II the measurement system is described, section III deals with measurement scenarios, the results are presented in section IV, and finally in section V we summarize the results.

## II. MEASUREMENT SYSTEM

4×4 MIMO channel sounding system based on the PN correlation method is developed to exploit the wideband properties of MIMO channel. The schematic diagram of the measurement system is given in Fig. 1. The measurement bandwidth of 20MHz is obtained by transmitting the pseudo noise (PN) sequence at the chip rate of 20 MHz using binary phase shift keying (BPSK) signal [5]. The center frequency of 5.8GHz was chosen to consider IEEE 802.11a wireless LAN standard.

The transmit system consists of four identical chains. Each chain is driven by signal generator transmitting modulated PN sequence with the bandwidth of 20MHz around the center frequency of 5.8 GHz. The signal from the signal generator is amplified by power amplifiers feeding omnidirectional transmit antennas. The transmit system is designed flexible so that any set of PN sequence can be generated to follow measurement requirement adaptively. In this study, the M-sequence of length 1023 was chosen to consider the fact that maximum excess delay is not more than 500 hundred nano-second for most of indoor environments such as office building, large retail store and warehouse, etc. [6]. The receive system also consists of four identical chains with omnidirectional receive antennas connected to LNAs amplifying the received signal. The amplified signal is down-converted to intermediate frequency (IF) by frequency mixer and fed into 4-channel digital oscilloscope, which digitizes the down converted IF signal and stores it on the PC for post-processing. At the digital oscilloscope, the down-converted IF signals are sampled at 250Ms/s rate which is several times of the signal bandwidth.

All frequency sources are phase locked to rubidium frequency standards, so that complex envelop of impulse response can be measured. The calibration procedure is completed before each measurement campaign to remove the effects of unequal channel gains and drifting phases in the transmitter and receiver modules. The calibration results are applied during the data post-processing to compensate the errors due to the measurement system. The measurement system parameters are shown in Table 1.

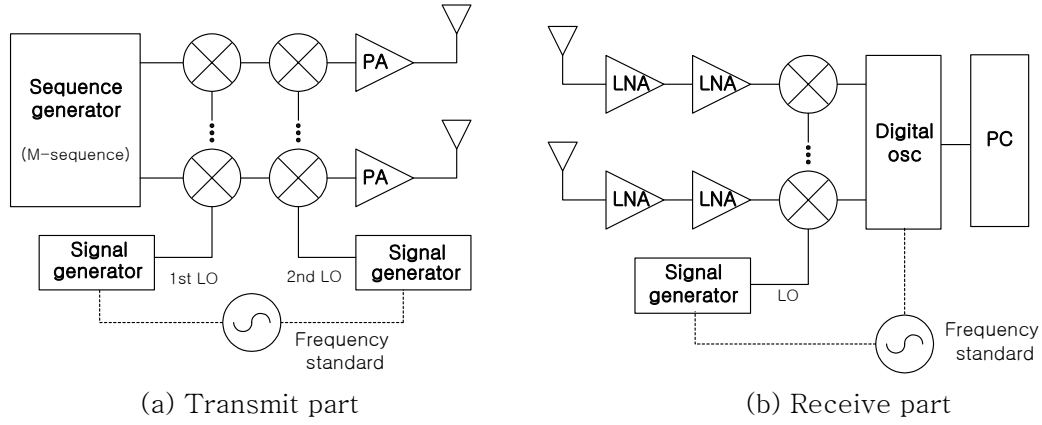

Fig. 1. The overview of 4×4 MIMO channel measurement system

Table I. The parameters of the measurement system

Center frequency	5.8GHz
Array configuration	Uniform linear arrays (4×4)
Antenna spacing	1λ, 4λ (Tx), 0.5λ~4λ (Rx)
Antenna height	1.6m
Transmit power	20dBm/antenna
PN sequence	10th order M-sequence
Chip rate	20MHz
Sampling rate	250Ms/s

### III. MEASUREMENTS SCENARIOS

Measurements were carried out changing the orientation and spacing of antennas at each receiver location. For the transmitter, the broad side of antennas is oriented to the center of the building in order to cover the entire building at the corner of corridor. The spacing of transmit antennas is chosen as one wavelength and four wavelengths, respectively. For the receiver, the antenna array is aligned along ‘east to west (EW)’ direction or ‘north to south (NS)’ direction and the spacing between array elements varies from half wavelength to four wavelengths by half wavelength step. EW or NS orientation is parallel or normal to the outer wall.

All the measurements were made at the 2nd floor of the building chosen in this study, which is a modern four-storied office building for the communication research institute in the university campus. The building is primarily made of reinforced concrete. The inner walls are made of concrete block or gypsum board. Some rooms have metal partitions from floor to ceiling, and the atrium is placed at the center of the building that is surrounded by pillars as shown in Fig. 2.

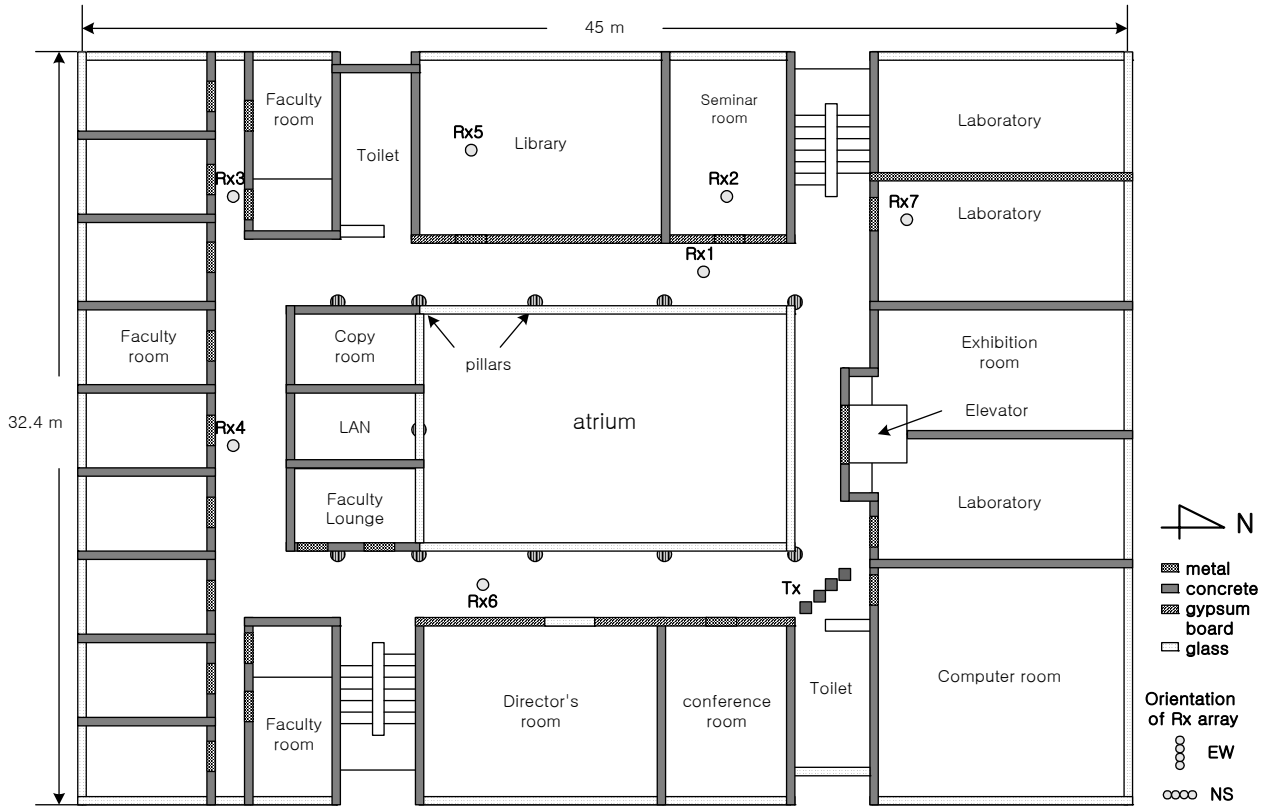

Fig. 2. Floor plan of measurement building

In this study, we measured channel impulse responses at seven different receive location with the fixed transmitter. Fig. 2 depicts transmitter and receiver locations. ‘Rx1’ and ‘Rx6’ have a line of sight (LOS) path from the transmitter and the other receivers are in non-line of sight (NLOS) condition. For each transmitting antenna spacing, 100 channel impulse responses per each Tx-Rx pair were collected for each receive antenna orientation and spacing of receive antenna array elements at one measurement location. During measurement campaign, moving people are allowed to observe temporal channel variation. The transmit and receive antennas were always maintained vertically polarized and fixed on the plastic mast at the height of 1.6m above the floor.

## IV. RESULTS and ANALYSIS

### A. Channel Impulse Response

Nearly 12000 measurements of MIMO channel were taken for each Tx-Rx pairs at seven receive locations on the second floor of the building. 16 channel impulse responses are obtained from each measurement.

Fig. 3 shows examples of impulse response snap shots for  $4 \times 4$  Tx-Rx pairs for LOS and NLOS paths. The column of the figure denotes receive antenna while the row implies transmit antenna in increasing sequence.

In each impulse response graph, the horizontal axis is time in  $\mu\text{s}$  and the vertical axis is received power in Watt. Fig. 3(a) is impulse responses at Rx1 having LOS path from the transmitter and Fig. 3(b) is at Rx3 having no LOS path from the transmitter.

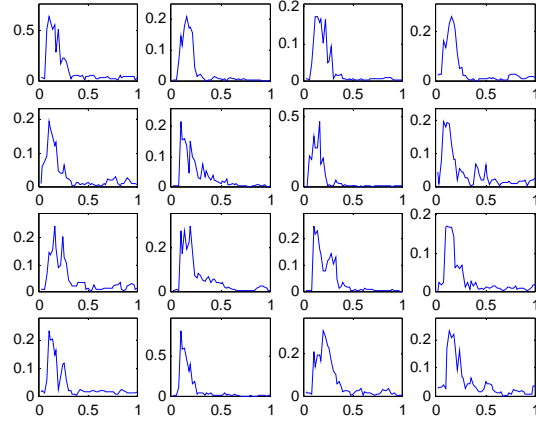

(a) Rx 1 position (LOS)

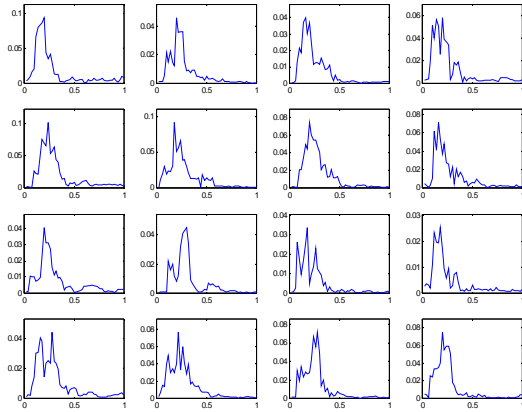

(b) Rx3 position (NLOS)

Fig. 3. Example of impulse response snap shots for  $4 \times 4$  Tx-Rx antenna system

### B. Rms Delay Spread and Mean Excess Delay

A summary of channel parameters obtained for different receive antenna location is given in Table II with the variance of each parameter in parenthesis. The rms delay spread and mean excess delay are calculated from measured power delay profiles for receive locations described in the preceding section. For the case that transmit antenna separation is four wavelengths, rms delay spread is higher than those for the case of one wavelength antenna separation by 3~8 ns in LOS location and 25~90 ns in NLOS location, respectively. The receive location Rx2 has no LOS path, but it is similar to the location having LOS path because the front wall is made of gypsum board, which is somewhat transparent at 5.8 GHz. Mean excess delay shows same tendency but has much higher value in nano seconds.

Table II. Rms delay spread and mean excess delay

Measurement Position	rms delay spread (ns)		mean excess delay (ns)	
	EW	NS	EW	NS
Rx1 (LOS)	38.5 (1.3)	36.2 (1.2)	55.8 (7.1)	46.6 (4.9)
Rx2 (NLOS)	39.1 (1.5)	43.0 (2.2)	48.8 (3.8)	54.7 (5.9)
Rx3 (NLOS)	38.3 (1.1)	36.1 (0.7)	62.6 (6.1)	56.5 (5.2)
Rx4 (NLOS)	48.7 (2.0)	42.1 (1.6)	69.8 (11.1)	62.5 (7.8)
Rx5 (NLOS)	50.9 (2.9)	51.8 (2.8)	62.6 (6.7)	61.3 (5.2)
Rx6 (LOS)	46.2 (1.9)	63.3 (2.7)	66.9 (9.2)	84.6 (10.9)
Rx7 (NLOS)	90.2 (4.8)	79.3 (3.7)	180.3 (23.1)	118.5 (12.9)

(a) Tx :  $1\lambda$  separation

Measurement Position	rms delay spread (ns)		mean excess delay (ns)	
	EW	NS	EW	NS
Rx1 (LOS)	44.6 (1.9)	44.3 (1.8)	74.5 (10.9)	69.6 (9.1)
Rx2 (NLOS)	44.6 (2.2)	45.6 (2.3)	55.1 (4.1)	57.0 (3.9)
Rx3 (NLOS)	62.4 (3.5)	64.2 (3.6)	83.3 (7.1)	88.7 (11.7)
Rx4 (NLOS)	138.9 (3.8)	123.9 (3.8)	222.1 (20.9)	217.9 (19.8)
Rx5 (NLOS)	138.2 (4.8)	138.3 (4.1)	209.6 (19.8)	213.0 (22.5)
Rx6 (LOS)	132.8 (3.8)	134.1 (4.2)	286.9 (21.5)	292.3 (17.3)
Rx7 (NLOS)	96.0 (3.5)	73.6 (3.1)	185.3 (15.3)	116.4 (13.1)

(b) Tx :  $4\lambda$  separation

### C. Channel Capacity

The theoretical channel capacity of the MIMO channel is of great interest since this reveals the benefits of using multiple antennas [1][7]. The capacity in bps/Hz of the MIMO wireless system with  $n_T$  transmit antennas and  $n_R$  receive antennas with an average received SNR  $\rho$  at each receive antenna is given by [1]

$$C = \log_2 \left( \det \left[ \mathbf{I}_{n_R} + \left( \frac{\rho}{n_T} \mathbf{H} \mathbf{H}^* \right) \right] \right)$$

where  $\mathbf{I}_{n_R}$  is the  $n_R \times n_R$  identity matrix and  $\mathbf{H}$  is the channel matrix.

A summary of the estimated channel capacities for the different receive antenna orientation and location is shown in Table III. The difference between the capacity of corresponding first 10% CDF and the capacity of corresponding first 90% CDF is not more than 2~3 bps/Hz and hence the available channel capacity is quite stable. The average capacity of a simulated independent and identically distributed Rayleigh channel is 13.84bps/Hz. Note that the capacity at Rx7 is larger than the others by 0.5~2 bps/Hz, because there are much scatterer or reflector made of metal

such as furniture, partitions, and equipments.

Fig. 4 depicts the CDF (cumulative distribution function) of channel capacities for different receive antenna spacing. Though they shows the similar tendency for the most of cases, the channel capacity for the case that the separation of antennas is odd multiple of half wavelength is slightly higher than that for the other cases.

Table III. Figures of the capacity statistics

Measurement Position	EW			NS		
	10%	50%	90%	10%	50%	90%
Rx1	9.60	10.26	10.98	9.45	10.25	11.01
Rx2	9.83	10.45	10.94	9.96	10.57	11.18
Rx3	10.16	10.68	11.20	10.32	10.87	11.38
Rx4	10.20	10.73	11.31	10.41	10.91	11.47
Rx5	10.28	10.91	11.52	10.34	10.86	11.38
Rx6	9.61	10.31	10.88	9.45	10.32	11.04
Rx7	11.69	12.14	12.55	11.69	12.17	12.65

(a) Tx :  $1\lambda$  separation

Measurement Position	EW			NS		
	10%	50%	90%	10%	50%	90%
Rx1	9.89	10.47	11.11	10.01	10.60	11.11
Rx2	9.79	10.57	11.19	10.28	10.94	11.57
Rx3	10.29	10.90	11.42	9.93	10.73	11.33
Rx4	10.51	10.85	11.21	10.52	10.85	11.18
Rx5	10.54	10.86	11.18	10.61	10.92	11.23
Rx6	10.34	10.70	11.06	10.08	10.58	10.92
Rx7	10.63	10.94	11.41	11.79	12.24	12.65

(b) Tx :  $4\lambda$  separation

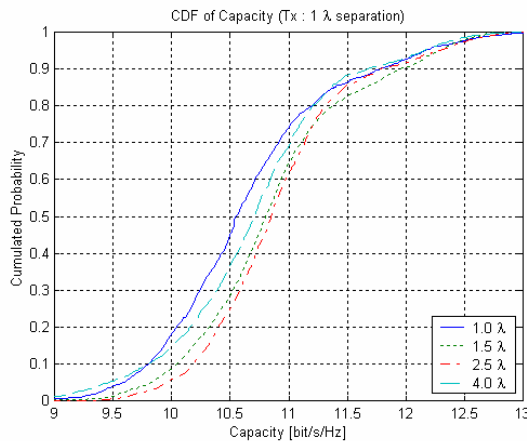

(a) Tx :  $1\lambda$  separation

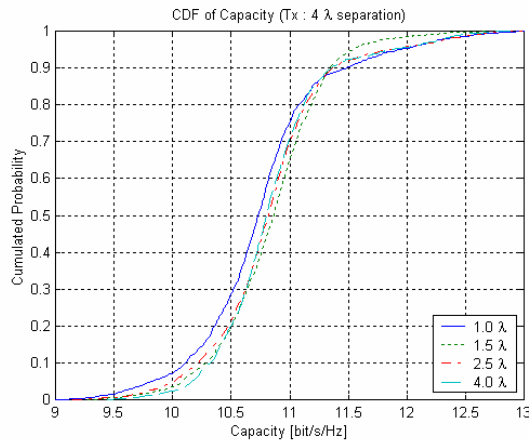

(b) Tx :  $4\lambda$  separation

Fig. 4. CDF of channel capacities

## V. CONCLUSIONS

The objective of this work is to measure MIMO channel impulse responses and estimate the capacity of indoor  $4 \times 4$  MIMO channels. Measurements were conducted in the modern office building with atrium changing the orientation and spacing of antennas. Rms delay spread and mean excess delay of four wavelengths spacing transmit antenna case is much larger than those of one wavelength case. In addition, the orientation of the antennas relative to the wall gives the slight influence on rms delay spread and mean excess delay. The capacities of the measured channels are quite stable and the capacity of rich scatterer environment is much higher than the others. Empirical wideband MIMO channel models using tapped delay line model will be developed.

## REFERENCES

- [1] G. J. Foschini and M. J. Gans, "On limits of wireless communications in a fading environment when using multiple antennas," *Wireless Personal Communications*, vol. 6, Mar. 1998.
- [2] P. Kyritsi, D. C. Cox, R. A. Valenzuela and P. W. Wolniansky, "Correlation analysis based on MIMO channel measurements in an indoor environment," *IEEE Journal on Selected Areas in Communications*, vol. 21, Jun. 2003
- [3] J. W. Wallace, M.A. Jensen, A. L. Swindlehurst and B.D. Jeffs, "Experimental characterization of the MIMO wireless channel: data acquisition and analysis," *IEEE Transactions on Wireless Communications*, vol. 2, Mar. 2003
- [4] H. Ozelik, M. Herdin, H. Hofstetter and E. Bonek, "Capacity of different MIMO systems based on indoor measurements at 5.2 GHz," *5th European Personal Mobile Communications Conference*, Apr. 2003



- [5] D. Cox, "Delay Doppler characteristics of multipath propagation at 910 MHz in a suburban mobile radio environment," IEEE Transactions on Antennas and Propagation, vol. 20 , Sep. 1972
- [6] A. Saleh and R. Valenzuela, "A Statistical Model for Indoor Multipath Propagation," IEEE Journal on Selected Areas in Communications, vol. 5, Feb. 1987
- [7] J. H. Winters, "On the capacity of radio communication systems with diversity in a Rayleigh fading environment," IEEE Journal on Selected Areas in Communications, vol. 5, Jun. 1987