

12GHZ BAND SHAPED REFLECTOR ANTENNA FOR BROADCASTING SATELLITES

Kazuyoshi Shogen, Hayato Nishida, and Noboru Toyama
NHK Science and Technical Research Laboratories
1-10-11, Kinuta, Setagaya-ku, Tokyo, 157 Japan

1. Introduction

For future DBS's in Japan, a more precisely contoured beam than that of BS-3's⁽¹⁾ is desirable for the onboard downlink antenna (12GHz band) such that the antenna gain is constant along the coastline of the major part of Japan.

For this purpose, we have designed and fabricated a downlink antenna using the single shaped reflector technique⁽²⁾. In this paper, we show an improved version of the downlink antenna, in which not only the radiation pattern is improved, but also sidelobe levels are effectively suppressed.

The antenna has been fabricated and the antenna performance has been verified by measurement.

2. Design condition

In this paper, the following conditions are assumed:

- (1) The orbital position of the DBS is 110 degrees east longitude.
- (2) The polarization is right hand circular polarization (RHCP).
- (3) The frequency band is 11.7-12.01GHz.
- (4) The antenna gain is more than 40dBi (referred to an isotropic radiator) in the major part of Japan and more than 28dBi in the other remote islands.
- (5) The co-polar and cross-polar radiation patterns meet the regulations in radio regulations appendix 30 (RR.AP30)⁽³⁾.

3. Antenna design

The diameter of the initial reflector, the focal length, and the offset angle are 2.3m, 1.84m, and 34.67deg., respectively (see Fig.1). The reflector is shaped as follows: first, the phase of the current induced on the reflector is optimized discretely on an aperture square grid^{(2),(4)}, second, the reflector is shaped to realize the optimized phase distribution⁽⁵⁾. The feed horn is assumed to radiate a Gaussian beam and illuminate the reflector edge at -14dB. The sidelobe level is effectively suppressed by setting constraint points of low gain in the sidelobe region of the far field and weighting these points during the optimization⁽⁶⁾.

4. Fabrication and measurement of antenna

Fig.2 shows the fabricated downlink antenna. The shaped reflector is made of CFRP-Alluminum honeycomb-CFRP. Fig.3 shows the calculated (dashed lines) and measured (solid lines) radiation patterns at 11.8GHz. The two radiation patterns agree well, and show that the 40dBi contour line encloses the

coastline of the four major Japanese islands and Okinawa, and the 28dBi contour line encloses the other remote islands.

Fig.4 shows the sidelobe and cross-polar characteristics along the dash-dotted line indicated in Fig.3. In Fig.4 the curves labeled as RR.AP30 are calculated under the assumption that the output power is 200W and the total feed loss is 2dB. It is seen from Fig.4 that the sidelobe and cross-polar characteristics meet the RR.AP30 regulations by a big margin.

Fig.5 shows the antenna gain and the minimum gain when the antenna pointing direction fluctuates by 0.1deg. for several big cities in Japan, as well as the gain of the BS-3 antenna⁽⁷⁾ for comparison. It is clear in Fig.5 that the amount of the variation in the antenna gain is about 1dB at each city.

4. Conclusions

The contoured beam antenna using the improved version of the single shaped reflector has been fabricated in the downlink frequency band for future DBS's in Japan. Its radiation pattern has been verified by measurement.

The radiation pattern covers the most of the major part of Japan at more than 40dBi and the other remote islands at more than 28dBi. Furthermore, the sidelobe and cross-polar characteristics meet the RR.AP30 regulations.

4. Acknowledgment

The authors wish to thank Dr. Utsumi in NHK Science and Technical Research Laboratories, for his encouragement throughout this research. They also wish to thank the staffs in NEC Corporation for fabricating the antenna and measuring the radiation pattern.

REFERENCES

- [1] Miura S., Toyama N., Ohmaru K., Shogen K., Obuchi T., Miyata Y. : "Electrical Performance of BS-3 Shaped-Beam Antenna", 12th AIAA Int. Communication Satellite Systems Conf., 88-0876, pp.660-669 (March 1988).
- [2] Shogen K., Nishida H., Toyama N. : "A Contoured Beam Shaped Reflector Antenna for Broadcasting Satellites", IEEE Int. Symp. on Antennas and Propagat., London, Canada, pp.686-689 (June 1991).
- [3] ITU : "Radio Regulations Appendix 30".
- [4] Cherrette A. R., Lee S.W., Acosta R. J. : "A Method for Producing a Shaped Contour Radiation Pattern Using a Single Shaped Reflector and a Single Feed", IEEE Trans. Antennas and Propagat., vol. AP-37, No.6, pp.698-706 (1989).
- [5] Shogen K., Ohmaru K. : "Contoured-Beam Antenna Using Shaped Offset-Fed Dual Reflectors for Broadcasting Satellites", Electronics and Communications in Japan, Scripta Technica Inc., Vol.74, No.6, pp.60-69 (1991).
- [6] Shogen K., Nishida H., Toyama N. : "Shaped Dual Reflector antenna for Broadcasting Satellites", IEICE Technical Report, AP90-43, Japan (1990).
- [7] Akanuma T., Toyama N., Miyata Y. Obuchi T. : "Electrical Performance of BS-3a Communication Antenna", Proc. of 1989 IEICE Fall Conference, B-88, Japan (1989).

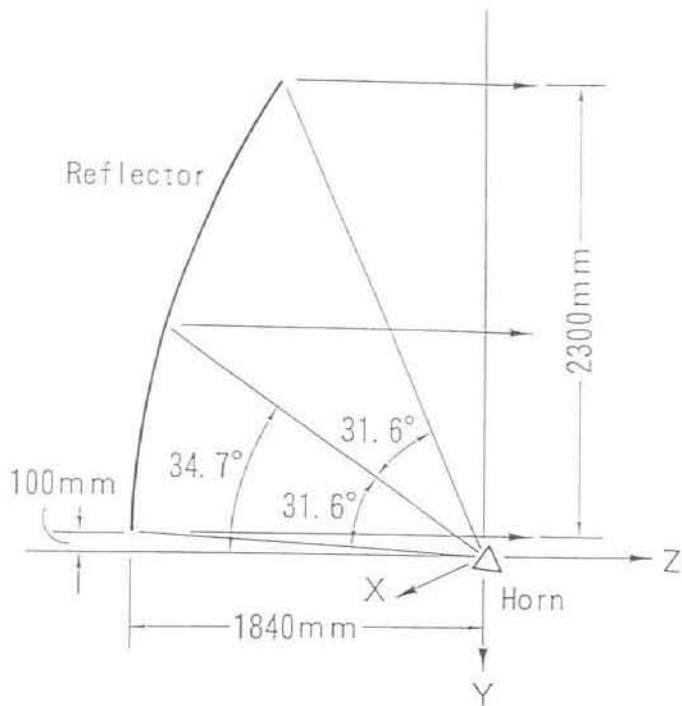

Fig.1 Geometry of the initial parabolic reflector.

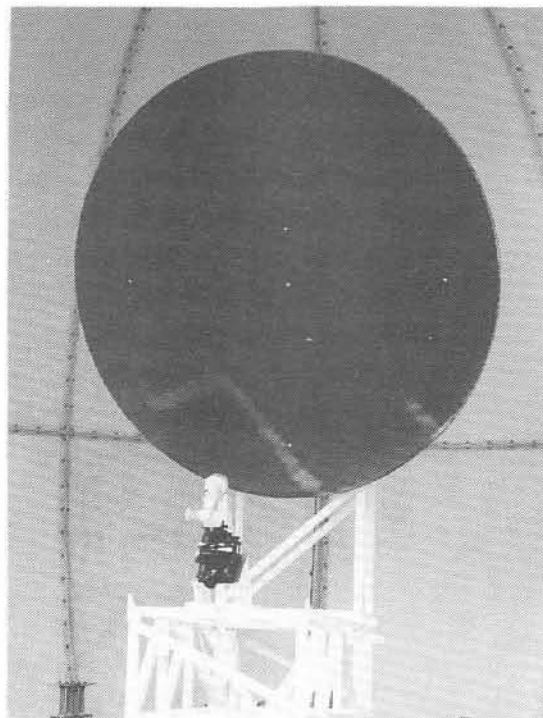

Fig.2 Fabricated antenna.

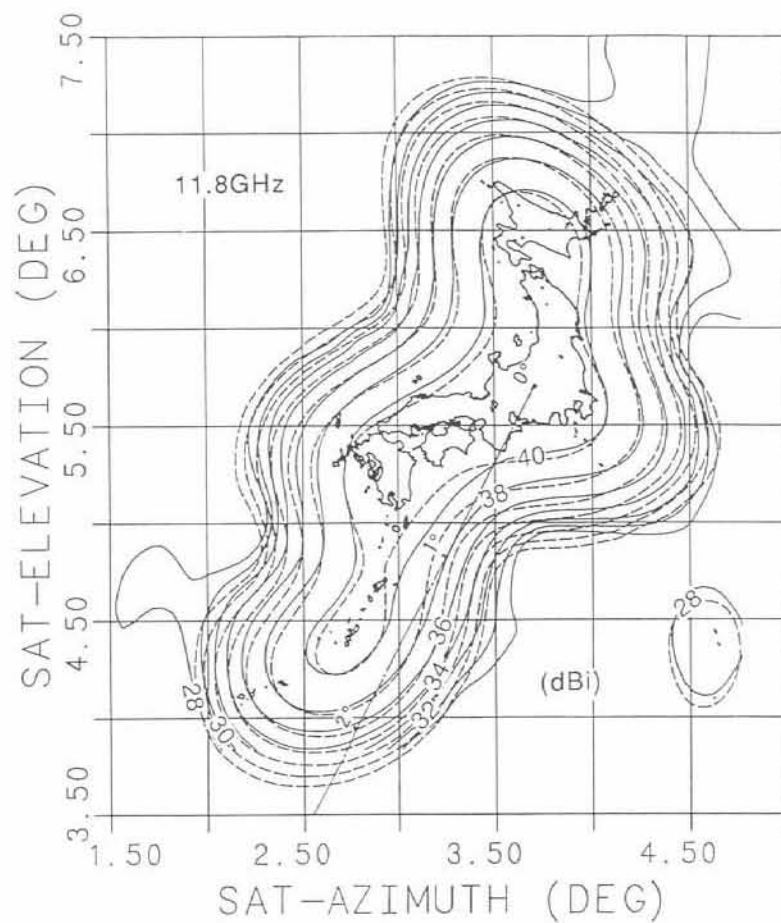

Fig.3 Co-polar (RHCP) radiation pattern at 11.8GHz.
 - - - : Calculated — : Measured

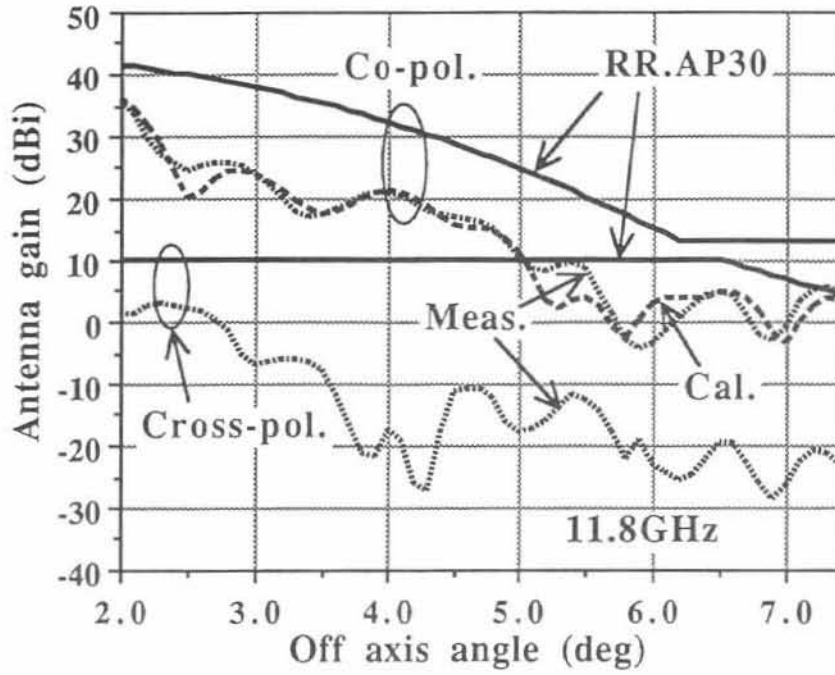

Fig.4 The sidelobe and cross-polar characteristics along the dash-dotted line indicated in Fig.3.

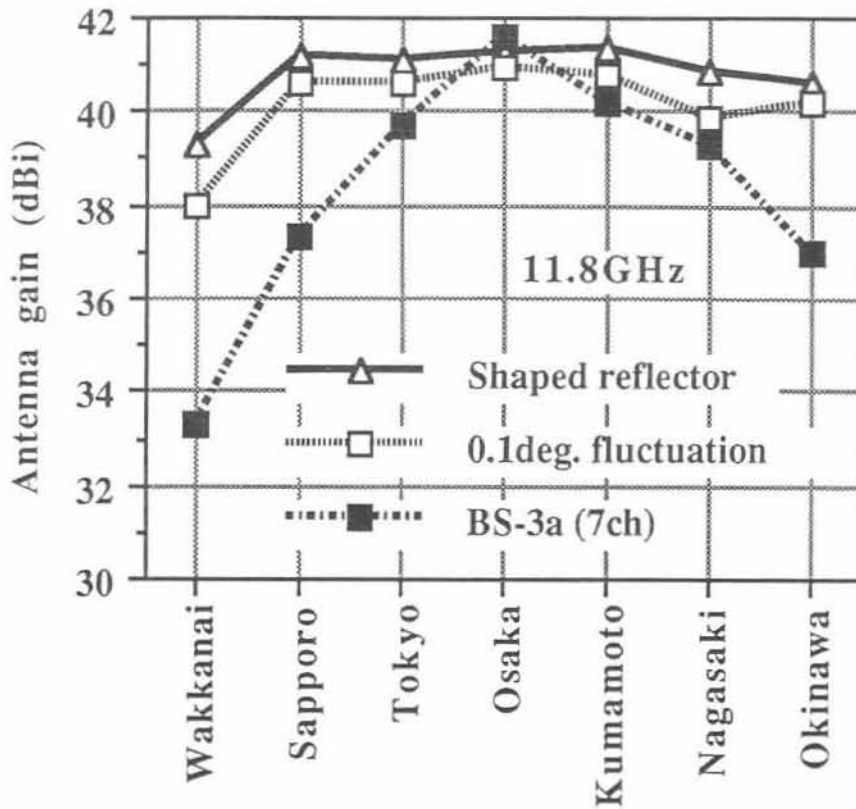

Fig.5 The antenna gain and the minimum gain when the antenna pointing direction fluctuates by 0.1deg..