

Basic Study on an Antenna Made of a Transparent Conductive Film

Ning Guan¹, Hirotaka Furuya¹, Kuniharu Himeno¹, Kenji Goto², and Koichi Ito³

¹ Optics and Electronics Laboratory, Fujikura Ltd., 1440, Mutsuzaki, Sakura, 285–8550, Japan

² Material Technology Laboratory, Fujikura Ltd., 1–5–1 Kiba, Koto-ku, Tokyo, 135–8512, Japan

³ Faculty of Engineering, Chiba University, 1–33, Yayoi-cho, Inage-ku, Chiba, 263–8522, Japan
guan@lab.fujikura.co.jp

Abstract

The radiation characteristics of a monopole antenna that consists of one-half of a bow-tie dipole antenna, made of optically transparent conductive thin film and mounted above a ground plane, are investigated. The antenna is measured for several films with different sheet resistivities. It is found that the gain lowering of the antenna varies from 4.4 dB to 0.2 dB at 2.4 GHz and the efficiency of the antenna increases from 46% to 93% at the same frequency, as the sheet resistivity decreases from $19.8 \Omega/\square$ to $1.3 \Omega/\square$, respectively. The antenna is analyzed by the moment method. A wire-grid model with resistance parallelly loaded on every discretized wire is applied. The analyzed results agree with the experimental ones very well.

1. INTRODUCTION

As mobile wireless communications have progressed dramatically in recent years, many mobile terminals are becoming smaller and smaller and miniaturization of the antennas employed in mobile devices is required accordingly. The design of antennas for small mobile terminals becomes much more difficult not only because the space is getting limited but also other electrical parts influence the performances of the antennas. Transparent conductive films, such as indium tin oxide (ITO) and fluorine-doped tin oxide (FTO) films, allow the transmission of electric currents while retaining the optical transparency [1]. If the transparent conductive films can be used for constructing antennas, the antennas can be installed on the surface or the display window of the mobile devices without much visible designing problem. Trials of transparent antennas have been reported [2]–[7] but some basic questions, such as how the resistance of the films influences the performances of the antennas, have not been cleared yet.

In order to study the basic performances of the antennas made of transparent conductive films, a monopole antenna that consists of one-half of a bow-tie dipole antenna mounted above a ground plane is investigated. The antenna is designed to work at 2.4 GHz and the radiation element of the antenna is made of several transparent conductive films with different sheet resistivities. It is found that the gain lowering of the antenna varies from 4.4 dB to 0.2 dB at 2.4 GHz, and the efficiency of the antenna increases from 46% to 93% at the

same frequency, as the sheet resistivity of the film decreases from $19.8 \Omega/\square$ to $1.3 \Omega/\square$, respectively.

The antenna is analyzed by a wire-grid model based on the moment method. The resistance of the film is taken into account by parallelly loading a resistance on every discretized element. It is the first time to treat an antenna with a resistive film in this manner, as far as the authors know. It is demonstrated after that the analyzed results are in good agreement with the experimental ones.

2. ANTENNA CONFIGURATION AND MEASUREMENT

Figure 1 shows the configuration of the antenna for the investigation. The film antenna is constructed on a glass substrate, which has a thickness of 1.1 mm and a relative dielectric constant of 4.8. The ground is a $300 \times 300 \text{ mm}^2$ copper square plate in the following measurement.

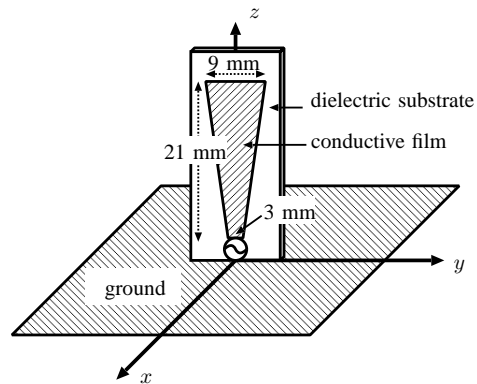

Fig. 1: Antenna configuration.

The antenna is made of ITO and FTO, as well as copper as a reference. We have fabricated several ITO and FTO films with different thicknesses so that the sheet resistivity of the ITO films varies from $19.8 \Omega/\square$ to $1.3 \Omega/\square$ and the one for the FTO films does from $5.7 \Omega/\square$ to $1.9 \Omega/\square$. Figure 2 shows a sample of the proposed ITO antenna and Fig. 3 the transmittance at a wavelength of 550 nm for the ITO and FTO films. We only present the result of the ITO antennas hereafter for the sake of simplicity, because the FTO antennas show almost the same radiation performances as the ITO's.



Fig. 2: Sample of ITO antenna.

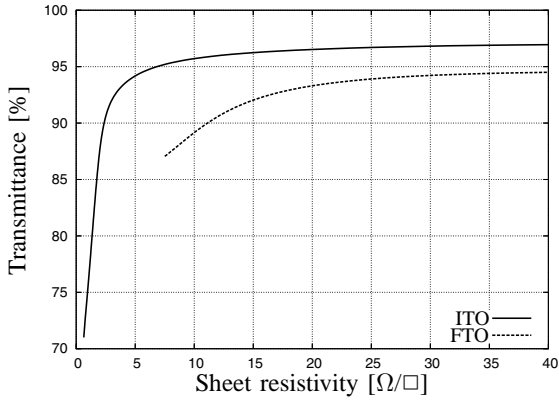

Fig. 3: Transmittance of ITO and FTO films at wavelength of 550 nm.

The measured voltage standing wave ratio (VSWR) of the antenna is shown in Fig. 4, where the characteristic impedance of the transmission line is 50Ω . It is shown that the VSWR does not vary so much as the sheet resistivity is lower than $10 \Omega/\square$.

The radiation patterns at 2.4 GHz and 5.0 GHz are measured and Figs. 5 and 6 show them at 2.4 GHz. The radiation pattern on XY -plane which is almost a constant is omitted. It is shown that the gain of the antenna increases as the resistivity decreases. For example, the maximum gain of the antenna decreases of 4.4 dB and 0.2 dB at 2.4 GHz, 2.5 dB and 0.4 dB at 5.0 GHz, for the antennas with resistivity of $19.8 \Omega/\square$ and $1.3 \Omega/\square$, respectively, if compared with a copper antenna with the same dimension.

The efficiency defined as the ratio of the radiated power to the input power is also measured at 2.4 GHz and 5.0 GHz by using the Wheeler cap method [8], [9]. For example, the efficiency is 46% and 93% at 2.4 GHz, 65% and 98% at 5.0 GHz, for the antennas with resistivity of $19.8 \Omega/\square$ and $1.3 \Omega/\square$, respectively.

3. SIMULATION

To numerically analyze the antenna, we apply a wire-grid model by using the software Numerical Electromagnetic Code version 4 [10]. The resistance of the film is taken into account

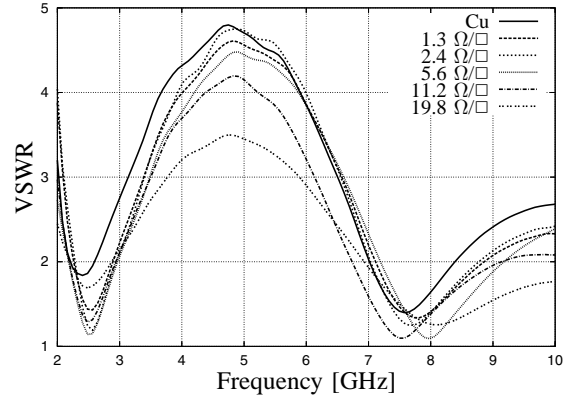

Fig. 4: Measurement of VSWR for antennas with substrate.

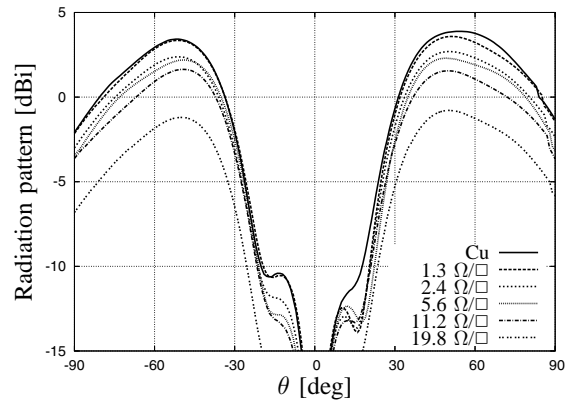

Fig. 5: Measurement of radiation pattern E_θ on XZ -plane at 2.4 GHz.

by parallelly loading a resistance on every discretized element. Because the typical thickness of the films is several hundred nanometers, far thinner than the skin depth at the operating frequencies, the loading resistance R_l for an element is just given by

$$R_l = \rho_s \Delta l / \Delta w$$

where ρ_s , Δl and Δw denote the sheet resistivity, the length and the width of the element, respectively. An infinite ground plane is assumed and the dielectric substrate is not included in the simulation.

Figure 7 shows the calculated VSWR for several sheet resistivities. Compared with the experimental results in Fig. 4, although the corresponding frequency seems to shift a little higher due to the lack of the dielectric substrate, the varying tendency is very similar with that of the experiment. For further comparison, we reasonably choose the numerical data at two frequencies of 2.8 GHz and 5.6 GHz to correspond with the experimental ones at 2.4 GHz and 5.0 GHz, respectively.

Figures 8 and 9 show the calculated radiation patterns at 2.8 GHz. The calculation is compared with the experiment in Fig. 10. Although the calculation differs a little with the experiment due to the limited dimension of the ground in

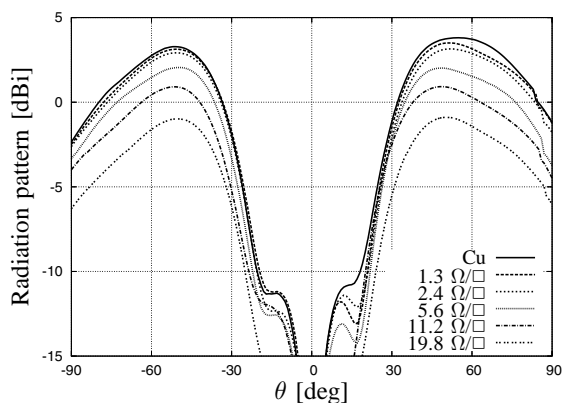

Fig. 6: Measurement of radiation pattern E_θ on YZ -plane at 2.4 GHz.

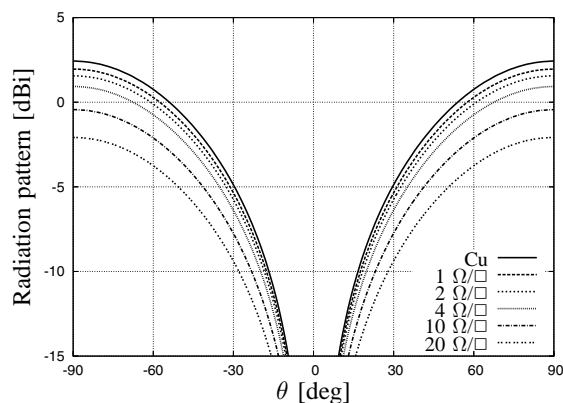

Fig. 8: Calculation of radiation pattern E_θ on XZ -plane at 2.8 GHz.

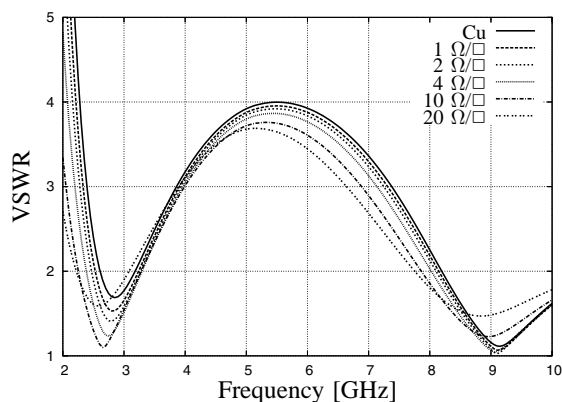

Fig. 7: Calculation of VSWR for antennas without substrate.

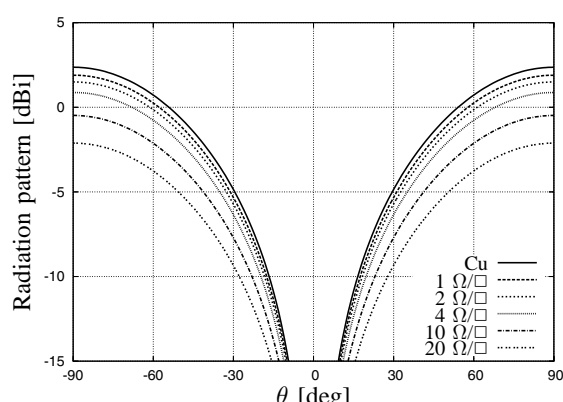

Fig. 9: Calculation of radiation pattern E_θ on YZ -plane at 2.8 GHz.

the experiment, the calculated gain has the same increasing tendency with that of the experiment as the sheet resistivity decreases.

The maximum gain of the antenna is calculated for varied sheet resistivity as shown in Fig. 11, where the gain is normalized to the value of the copper antenna. It is shown that the gain lowering depends also on frequency and shows a minimum at about 5 GHz. This dependence is considered to be an inherent feature of the antenna. The calculated results at 2.8 GHz and 5.6 GHz are compared with the measured ones at 2.4 GHz and 5.0 GHz, respectively, as shown in Fig. 12. It is shown that the calculation and the experiment are in good agreement with each other. According to the calculation, the rate of the gain lowering at 2.8 GHz is about 0.20 dB/ Ω/\square and that at 5.6 GHz is 0.12 dB/ Ω/\square .

The efficiency of the antenna is also calculated for varied sheet resistivity as shown in Fig. 13. It has a similar frequency dependence with the gain in Fig. 11. The calculated results at 2.8 GHz and 5.6 GHz are also compared with the measured ones at 2.4 GHz and 5.0 GHz, respectively, as shown in Fig. 14. It is shown that the calculation and the experiment are in good agreement with each other too. According to the

calculation, the rate of the efficiency lowering at 2.8 GHz is about 2.7 %/ Ω/\square and that at 5.6 GHz is 1.7 %/ Ω/\square .

4. CONCLUSION

We have experimentally investigated an antenna made of a transparent conductive film. It is found that the gain lowering of the antenna varies from 4.4 dB to 0.2 dB, the efficiency increases from 46 % to 93 % at 2.4 GHz, as the sheet resistivity of the film decreases from 19.8 Ω/\square to 1.3 Ω/\square , respectively. We have also successfully analyzed the antenna by using a wire-grid model based on the moment method. The analysis agrees with the experiment very well. It is estimated from the analysis that the rate of the gain lowering is 0.20 dB/ Ω/\square and the rate of the efficiency lowering is 2.7 %/ Ω/\square at 2.8 GHz. We have obtained some quantitative data for the employment of the transparent conductive films with antennas and have shown that the ITO and FTO films can be used for practical antennas. It is expected that the transparent conductive films can provide a useful means for the antennas employed in mobile terminals in the near future.

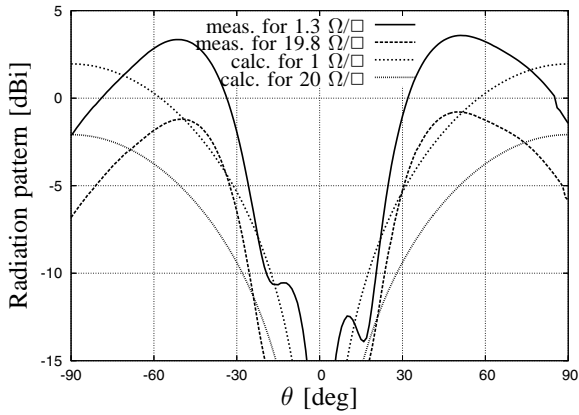

Fig. 10: Comparison of radiation pattern E_θ on XZ -plane.

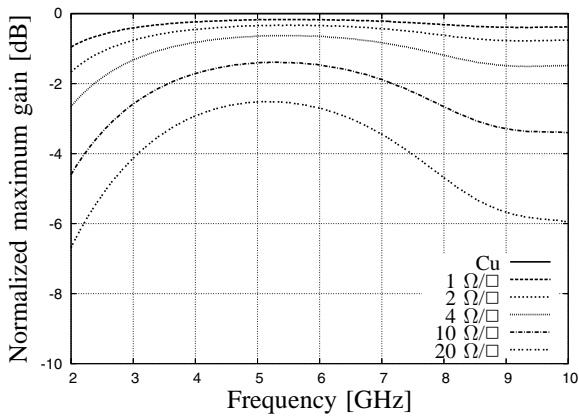

Fig. 11: Calculation of maximum gain dependence on frequency.

REFERENCES

- [1] T. Kawashima, H. Matsui, and N. Tanabe, "New transparent conductive films: FTO coated ITO", *Thin Solid Films*, vol. 445, no. 2, pp. 241–244, 2003.
- [2] M. S. Wu and K. Ito, "Meshed microstrip antennas constructed on a transparent substrate," *IEICE Trans.*, vol. E-74, no. 5, pp. 1277–1282, 1991.
- [3] R. N. Simons and R. Q. Lee, "Feasibility study of optically transparent microstrip patch antenna," *IEEE AP-S Int. Symp.*, pp. 2100–2103, 1997.
- [4] M. Outaleb, J. Pinel, M. Drissi, and O. Bonnaud, "Microwave planar antenna with rf-sputtered indium tin oxide films," *Microwave and Opt. Technol. Lett.*, vol. 24, no. 1, pp. 3–7, 2000.
- [5] C. Mias, C. Tsakonas, N. Prountzos, D. C. Koutsogeorgis, S. C. Liew, C. Oswald, R. Ranson, W. M. Cranton, and C. B. Thomas, "Optically transparent microstrip antennas," *IEE Colloquium on Antennas for Automotives*, pp. 8/1–8/6, 2000.
- [6] K. Oshima, N. Kidera, K. Niwano, K. Ikawa, R. Sonoda, and S. Kawasaki, "Use of a transparent conductive thin-film on a glass substrate in active integrated antenna arrays with double strong coupling," *IEEE MTT-S Int. Microwave Symp. Dig.*, pp. 1569–1572, 2002.
- [7] C-F. Huang and L. Chen, "Realization of a printed-on-display antenna for mobile terminals," *Elect. Lett.*, vol. 38, no. 20, pp. 1162–1163, 2002.
- [8] H. A. Wheeler, "The radiansphere around a small antenna," *Proc. IRE*, vol. 47, pp. 1325–1331, 1959.
- [9] M. Andoh, S. Ishida, and K. Itoh, "Efficiency measurement of electrically small antenna using Wheeler cap method," *General Conf. IEICE*, S8-3, vol. 3, pp. 285–286, 1987. (in Japanese)
- [10] <http://www.lnl.gov/IPandC/technology/software/softwaretitles/nec.php>.

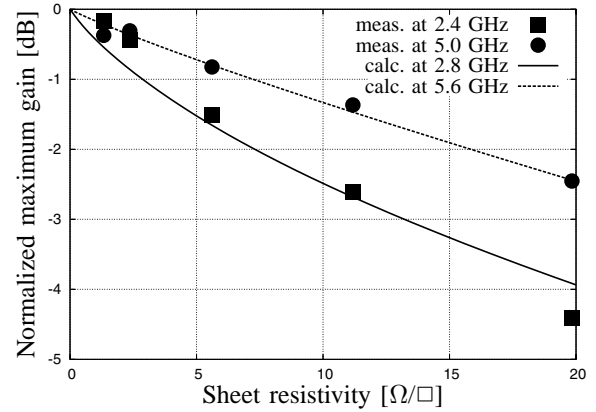

Fig. 12: Comparison of maximum gain.

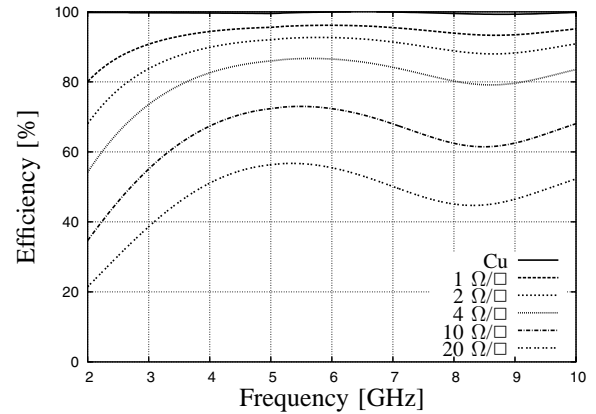

Fig. 13: Calculation of efficiency dependence on frequency.

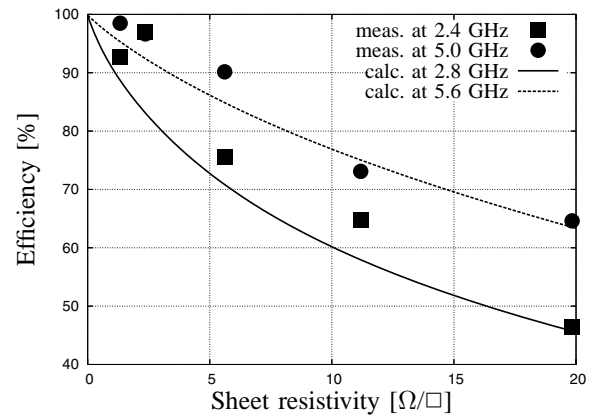

Fig. 14: Comparison of efficiency.