

DOA Estimation Measurement using Fabricated 4-Ch Low-IF Receiver

Kyeong-Sik Min, Chul-Keun Park and Jee-Won Ko
 Department of Radio Science & Engineering,
 College of Sciences and Engineering, Korea Maritime University,
 #1 Dongsam-Dong, Youngdo-Ku, Busan 606-791, Korea
 E-mail: ksmin@mail.hhu.ac.kr

1. Introduction

Wireless communication technologies have greatly progressed in recent years and the markets, especially in the mobile communication have been growing enormously. Moreover the next generation communication services will use higher frequency band, and require more channel capacity and wider bandwidth for a high-speed data communication than nowadays. As a large increase in channel capacity and high transmission rates for wireless communications, the technologies for the power saving and efficient frequency usability are required. To meet the requirements of the next generation wireless communications, a system capable to automatically change the directionality of its radiation patterns in response to its signal environment must be indispensable. The use of spatial resource can noticeably increase the performance such as capacity and quality of a wireless system. The concept of a DBF (Digital Beam Forming) antenna system is to control automatically an antenna's reception beam pattern by digital signal processing [1].

The DBF antenna system uses spatially separated antennas called array antenna and processes the received signals with a digital signal processor after analog to digital conversion. The main concept of the DBF antenna system is the automatic or adaptive control of antenna's beam pattern by digital signal processing with a software algorithm. A digital device capable of high speed real-time processing, consuming low power and programmable is required for practical use of the DBF antenna system in wireless communications. In recent year, a FPGA for the implementation of the DBF antenna system meets the requirements of high performance processing, programmability and low power consumption [2]. This paper describes the DOA (Direction Of Arrival) estimation using MUSIC (Multiple Signal Classification) algorithm for the DOA estimation measurement system using 4-Ch DBF receiver with resistive FET mixer.

2. Construction of measurement system

2-1. 4-Ch resistive FET mixer with LNA

Fig. 1 shows the structure of the 4-Ch resistive FET mixer with LNA. The signals supplied the RF and the LO input terminal are 2.09 GHz and 2.08 GHz, respectively. The LO signal is supplied to four mixers by 5-port power divider. In order to obtain the IF signal of 10 MHz at each port, the RF signal and the LO signal are mixed each other at the mixer.

Fig. 2 shows the photograph of the fabricated 4-Ch low-IF receiver with resistive FET mixer. The calculated and measured maximum power gains observed at LNA are 15 dB and 11 dBm, respectively. When the LO input power and voltage V_{GS} impressed by bias circuit are constantly given 6 dBm and -0.4 V, respectively, the IF output power is controlled by the RF input power [3].

2-2. Configuration of A/D control box

Fig. 3 shows the photograph of the A/D control box. The A/D control box is composed of CPU board, I/O motherboard and 2 ADC board. The CPU board is used for system control, FPGA configuration and user interface support of telnet or FTP via ethernet. The I/O motherboard performs I/O control of ADC sampled data, supplies powers of multiple standards to the system and sampling clock management. On the I/O motherboard, the ADC boards are stacked with a socket. An ADC board has 2 FPGAs and each FPGA controls 4 channels of ADCs [4]. 16 terminals as shown in fig. 3 are connected to each IF channel of a fabricated receiver.

2-3. Measurement environment

In order to measure the basic characteristics of DOA estimation, 4-Ch low-IF receiver is adopted and experiment is performed at the anechoic chamber. Instruments for measurement are composed of 4 antennas, 4-Ch resistive FET mixer, 4-terminal of A/D control box and monitoring computer. Table 1 represents the specification of measurement system. The frequency band of RF, LO and IF are 2.09 GHz, 2.08 GHz and 10 MHz, respectively. The power levels of Rx, LO and IF are -40 dBm, 6 dBm and about -50 dBm, respectively.

The power of transmitting antenna (Tx) using a broadband standard horn is supplied by the signal generator. Receiving antenna (Rx) is fabricated 4-element monopole linear array. Since distance between Tx antenna and Rx antenna is depended on eq (1), the distance of far field required in the measurement is determined 3 meter (20.9λ). The photograph of the Tx and Rx antennas are shown in Fig. 4. A/D control box has 12-bit resolution and sampling rates is up to 40 MHz.

$$R \geq \frac{2 \times D^2}{\lambda} \quad (1)$$

Note that R is a distance between Tx and Rx antenna, and D is a surface of antenna.

3. Experiment Results

Fig. 5 shows the beam direction results of the DOA estimation computed by FPGA using only 4 channels. The observed DOA means an angle of each direction received from one transmitting signal source. The measurement of DOA estimation with MUSIC algorithm shows reasonable result although a little bit error exists at the direction of 30° and -30° .

Fig. 6 shows the measured DOA estimation results observed by 4-CH receiver when transmitting signal source is two signals simultaneously. Two transmitting signal sources are divided by wilkinson type 3-port power divider. It shows that DOA estimation results with respect to double signal sources are worse than ones of single signal source. Due to increase of correlation interference between the receiving antenna elements and to weakness of the received signal, DOA estimation performance is not good. Because the MUSIC algorithm is assumed that array antenna elements are independence with respect to correlation coefficients each other, Difference between theoretical result and experimental result appears frequently. Therefore, in order to obtain the precise DOA estimation result, weak mutual coupling coefficients between antenna elements, increase of the receiving elements and development of improved algorithm are strongly required.

4. Conclusion

This paper describes the DOA estimation measurement by MUSIC algorithm using fabricated 4-Ch low-IF receiver. Operating frequency of RF, LO and IF signal considered in this paper is 2.09 GHz, 2.08 GHz and 10 MHz, respectively. In measurement, because of increase of correlation interference between antenna elements and weakness of the received signal, DOA estimation results

with respect to double signal sources are worse than ones of single signal source. As the future study, research for the weakly coupled antenna elements and for the improved algorithm development will be performed.

Acknowledgement

This research is partly supported by the fund from Samsung Advanced Institute of Technology (SAIT) and Human Resource Development for Region Innovation of KOTEF in Korea. The authors would like to thank Prof. Hiroyuki Arai and Mr. Min Seok Kim of Yokohama National Univ., for the many helpful discussions and advices regarding the DOA estimation and ADC operation.

References

- [1] Y. Karasawa, "The Software Antenna: A New Concept of Kaleidoscopic Antenna in Multimedia Radio and Mobile Computing Era," *IEICE Trans., Comm.*, Vol. E80-B, No. 8, pp.1214-1217, Aug. 1997.
- [2] B. Fawcett and R. Iwanczuk, *Techniques and Tools for FPGA-based DSP design*, Xilinx Inc..
- [3] Jee-Won Ko, Kyeong-Sik and Hiroyuki ARAI, "Design for the Low IF Resistive FET Mixer for the 4-Ch DBF receiver," *JKEES*, Vol. 2, No. 2, pp.117-123, Nov. 2002
- [4] Minseok Kim, Koichi Ichige, Hirouki Arai and Koichi Tsunekawa, "Adaptive Array Antenna Experimental System based on FPGAs and its evaluation through implementation of MRC beamformer," Technical Report of IEICE, AP-2002-38.

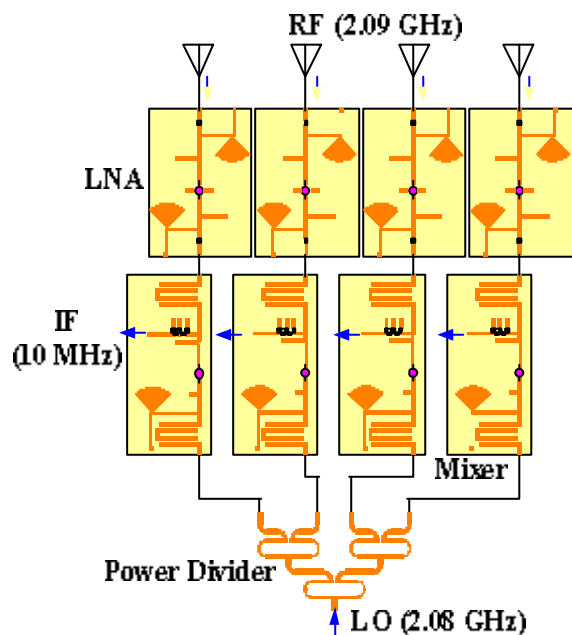

Fig. 1 Structure of the 4-Ch resistive FET mixer.

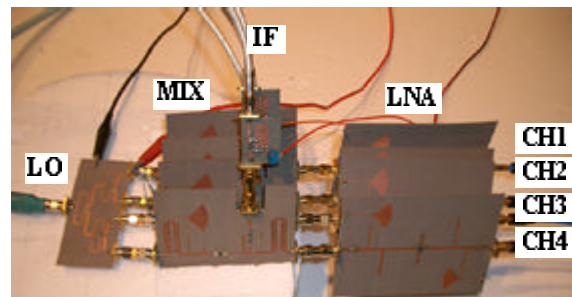

Fig. 2 4-Ch low-IF mixer with LNA.



Fig. 3 Photograph of A/D control box.

Table 1. Specification of measurement system.

	Specification
Frequency [GHz]	RF : 2.09 LO : 2.08 IF : 0.01
Level [dBm]	RF Rx : -40 dBm LO : 6 dBm IF : -50 dBm
Voltage[V]	-0.4 V
Tx Ant.	Broadband standard horn antenna 1 GHz ~ 18 GHz
Rx Ant.	2.09 GHz monopole 4-element array
Distance of Tx and Rx	3 m
A/D Converter	12 bit, 40 MHz/s

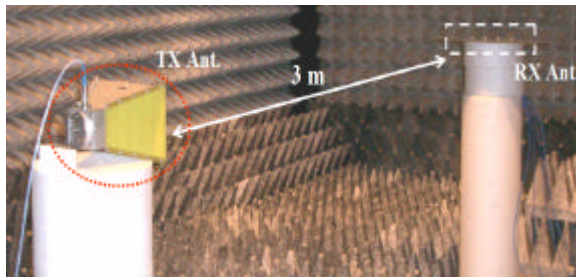

Fig. 4 Arrangement of Tx & Rx antenna.

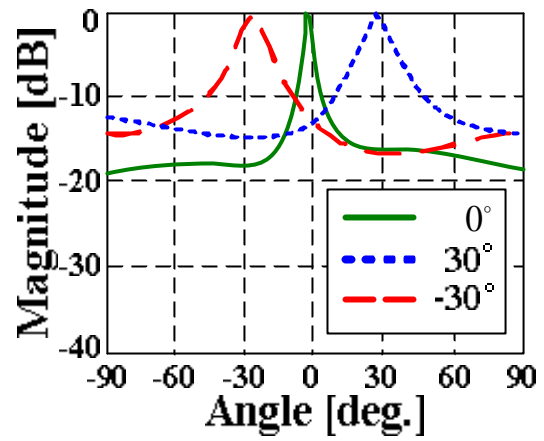

Fig. 5 DOA estimation results for one signal.

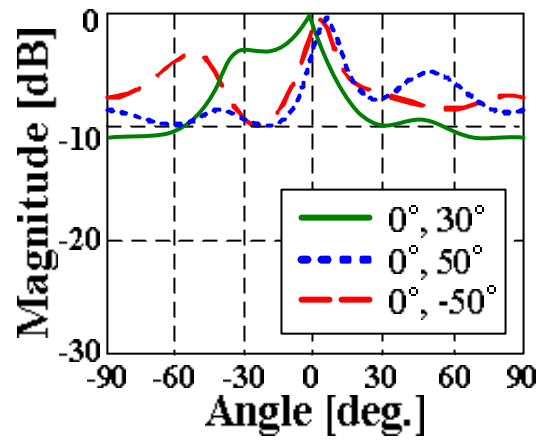

Fig. 6 DOA estimation results for two signals.