

Reconfigurable beam steering using dipole and loop combined antenna

Sangjun Ha, Yongjin Kim*, Chang Won Jung

Graduate School of NID Fusion Technology, Seoul National University of Technology
172, Seoul, 139-746, Korea

*Department of Electric Information, Inha Technical College
253, Incheon, 402-752, Korea
E-mail: changwoj@snut.ac.kr

I . Introduction

Recently, the wireless systems include a large number of techniques that attempt to enhance the received signal, suppress all interfering signals, and increase capacity. Accordingly, these systems have been suggested for communication systems to overcome the problem of limited channel bandwidth, satisfying a growing demand for a large number of mobiles on communications channels^[1]. The systems are usually categorized as either switched-beam or adaptive-array systems. The switched-beam approach further subdivides the macro-sectors into several micro-sectors. Typically, the switched-beam system establishes certain choices of beam patterns before deployment, and the method cover wide region. Each micro-sector contains a predetermined fixed beam pattern, with the greatest gain placed in the center of the beam^[2].

In this paper, we propose a reconfigurable beam steering antenna using a folded dipole and a loop. The radiation patterns of the two antennas was cancelled or compensated, and head for the specific direction when the dipole and loop antenna are combined at the reasonable ratio. The structure of the antenna is very simple and planar. By changing on/off states of switches, the proposed antenna can steer the beam direction in the x-y plane. Simulation results confirmed the steering characteristic by using two imaginal switches. The proposed antenna can change the direction of the maximum gain in the x-y plane ($0^\circ, \pm 50^\circ$). The proposed antenna operates in 2.5GHz ~ 2.56GHz (VSWR < 2). It was showed that peak gain of the antenna is 1.96 ~ 2.48dBi and overall beam width of the reconfigurable antenna covers about 125° .

II . Antenna configuration and design

2-1 Design concept

Fig. 1 depicts the design concept of the proposed antenna. Impedance characteristic of the dipole antenna is capacitive and the loop antenna is inductive. When two antennas combined, the characteristic was canceled or compensated each other and the fabrication of small antennas can be possible^[3]. Fig. 2 shows the proposed beam steering antenna. The length of the dipole antenna for the operation frequency of 2.5 GHz is 28mm. The circumference of the loop antenna is 74mm. Two antennas are contact each other through the imaginal two switches as shown in fig. 2. Table 1 shows the possible three combinations with the two switches.

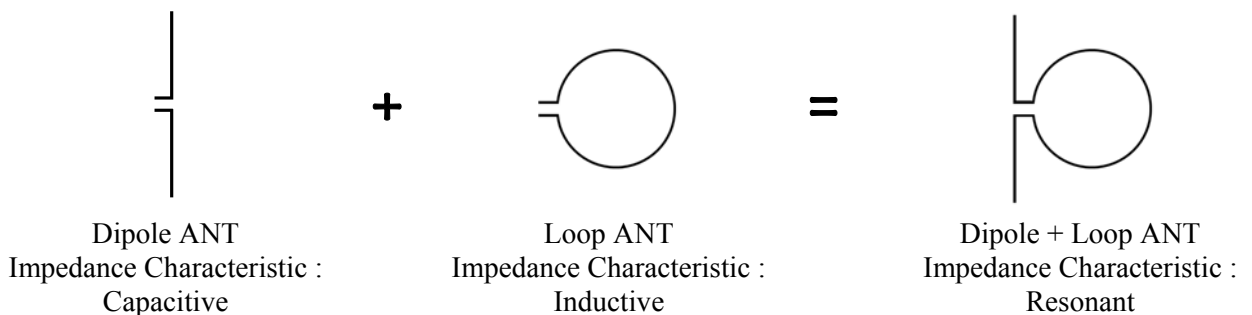
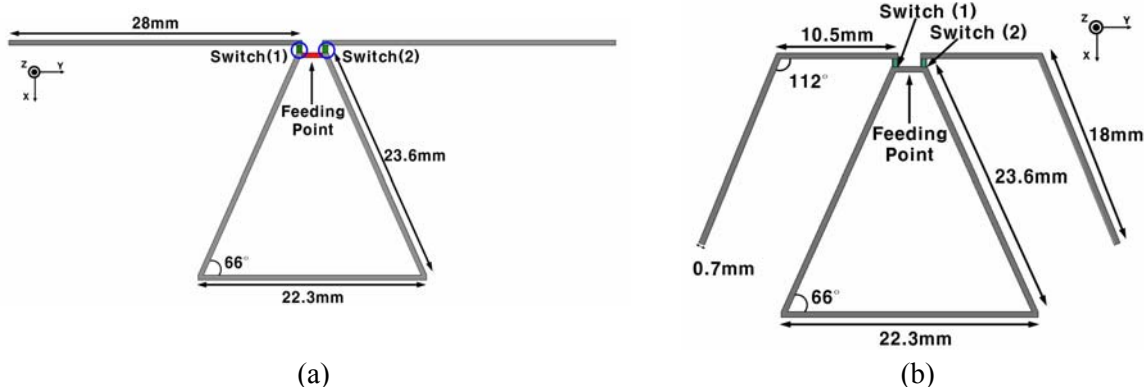

Fig. 1 Impedance matching concept of the proposed antenna



(a) (b)
 Fig. 2 (a) Geometry of the dipole and loop combined antenna
 (b) Geometry of the optimized antenna

Table 1 The antenna states by the switches ON/OFF

State	Switch (1)	Switch (2)
S0	ON	ON
S1	ON	OFF
S2	OFF	ON

2-2 Antenna configuration and design

To improve return loss and gain, traditional circular loop was transformed to triangular loop antenna [4]. The center frequency of S0 is 2.6GHz and S1, 2 is 2.5GHz. To match the center frequency of two antennas, the dipole antenna was transformed to folded dipole antenna as shown in fig. 2 (b). Fig. 3 (a) shows simulated return loss variation of the two antenna states (S0, S2). The return losses of two states are varied by the inclined angle (α°) of the folded dipole at the center frequency 2.5GHz. The return losses of two states are under -10dB at the angle (α°) between $19^\circ \sim 26^\circ$. Therefore, we decided the inclined angle (α°) of the three antenna states (S0, S1, S2) to $19^\circ \sim 26^\circ$ and the antennas of three states operate in the same frequency of 2.5 GHz.

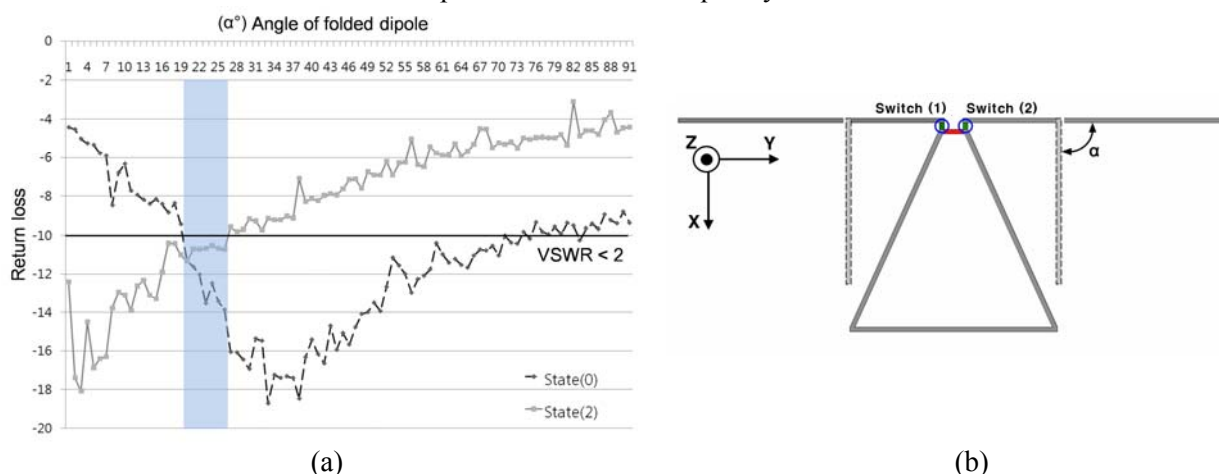

(a) (b)
 Fig. 3 (a) Return losses versus the inclined angle of the folded dipole
 (b) The inclined angle of the folded dipole

III. Measurement result and discussion

Fig. 4 shows the picture of the fabricated antennas which are representing 3 types by the imaginal switch states, S0, S1, and S2. Fig. 5 shows the return losses of the antenna by the states. The substrate is FR-4 with a thickness of 1mm and the dimension is $38\text{mm} \times 20\text{mm}$. All of the states are operating at the center frequency, 2.5 GHz. The bandwidth is about $40 \sim 60$ MHz

(VSWR < 2). Fig. 6 shows the measured radiation patterns (x-y plane) and the simulated 3D radiation patterns of the three antenna states, (a) S0, (b) S1, (c) S2. The measured beam patterns of the three antenna states show the typical dipole antenna and they show that the maximum beam directions are clearly changed by the switches operation. The maximum gain is 2.48dBi at $\phi_{\max} = 175^\circ$ and the HPBW is 75° when the antenna is S0, the maximum gain is 2.11 dBi at $\phi_{\max} = 120^\circ$ and the HPBW is a 85° when the antenna is S1, and the maximum gain is 1.96 dBi at $\phi_{\max} = 225^\circ$ and the HPBW is about 90° when the antenna is S2. We decided the overall beam width of three antenna states to the -1dB point (1.48dBi) from the maximum gain, 2.48dBi, of the S0. The overall beam width of S0, S1, and S2 are wide angle of 125° .

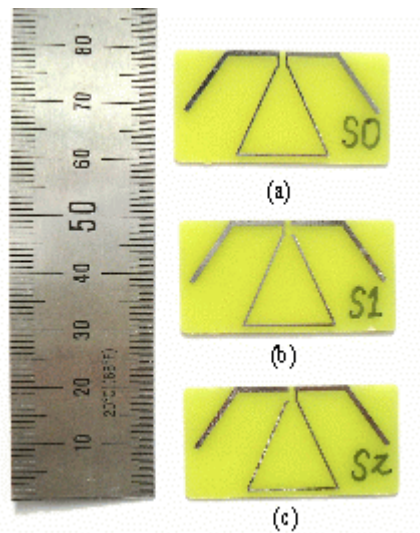

Fig. 4 Photograph of the proposed antenna (a) S0, (b) S1, (c) S2

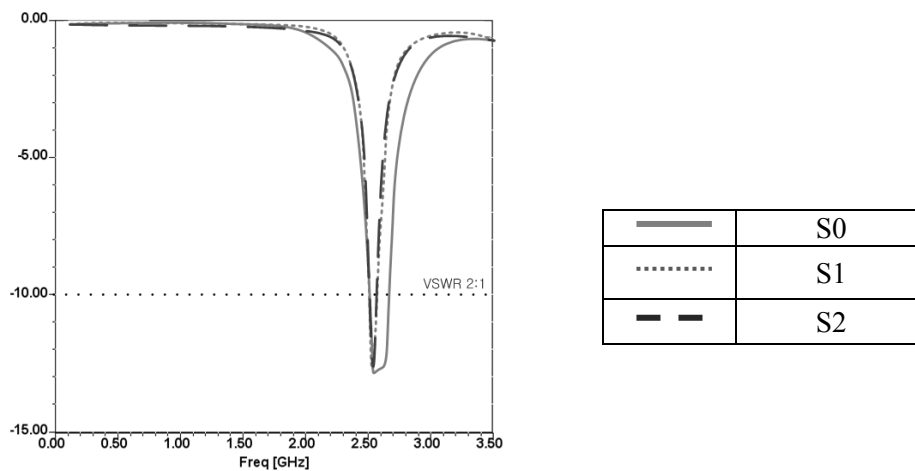
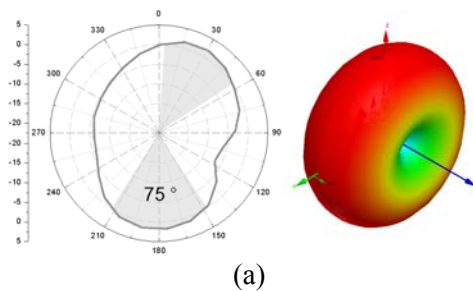

Fig. 5 Measured return losses



(a)

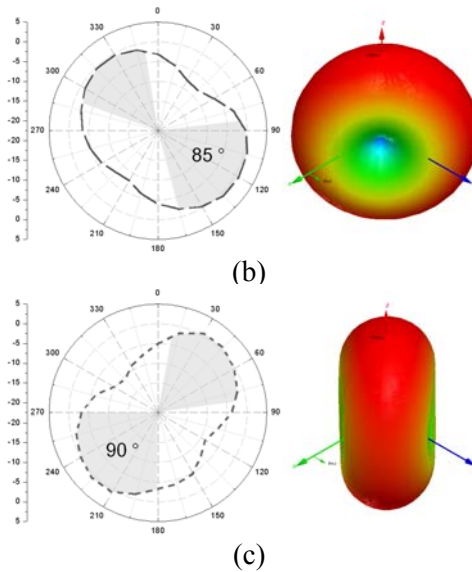

Fig. 6 Measured radiation patterns (a) S0, (b) S1, (c) S2

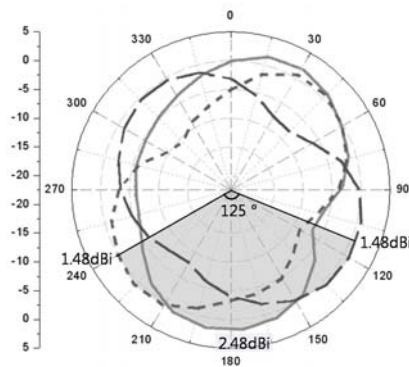

Fig. 7 Overall beam steering range (X-Y plane)

III. Conclusions

This paper presents a beam steering method using the dipole and loop antenna. The proposed beam steering antenna realized using two imaginal switches. The operating frequencies of three states are matched to 2.5 GHz by folding the dipole line. The antenna gain is about 2.5 dBi ~ 1.5 dBi within $\phi = 120^\circ \sim 225^\circ$. The VSWR of all the switching cases is less than 2 in the operating frequency of 2.5 GHz. The proposed antenna structure is easy to design using the planar single antenna element for the beam steering and able to apply in the various communication systems requiring efficient beam steering.

Acknowledgments

This research was supported by Basic Science Research Program through the National research Foundation of Korea (NRF) funded by the Ministry of Education, Science and Technology (No. 2010-0003086).

References

- [1] A. Alexiou, M. Haard, Smart antenna technologies for future wireless systems: trends and challenges, *IEEE Communications Magazine*, 42 (2004), 90-97.
- [2] Chryssomallis, M. Smart Antennas, *IEEE Antennas and Propagation Magazine*, 42 (2000), 129-136.
- [3] Yougjin Kim, Chang won Jung. Small UWB Antenna with Combination of Electric-Magnetic Radiators, *Korean Institute of Electrical Engineers*, 58 (2009), 33-37
- [4] C. A. Balanis, *Antenna Theory Analysis and Design*, 2nd Ed., New York: John Wiley & Sons, (2001) 249-250,