

# Measurement of Radiation Pattern of Large Deployable Reflector Antenna equipped on Engineering Test Satellite (ETS-VIII) on Orbit

Teruaki Oriksa, Yoshiyuki Fujino, Masaki Satoh

Kashima Space Research Center, National Institute of Information and Communication Technology  
893-1 Hirai, Kashima, Ibaraki 314-8501, Japan E-mail : {t.orihsa, fujino, sato}@nict.go.jp

## 1. Introduction

Engineering test satellite VIII(ETS-VIII) was launched at December 2006. Many communication technologies are experimented and evaluated the performances. This Satellite is equipped with the large deployable reflector antenna (LDRA) for land mobile communications with the size of 17m x 18 m, which is one of the largest size for communications satellite. First, we describe the measurement of radiation patterns of this antenna on orbit, Comparing the measurement and calculated results, actual beam positions are little bit shifted and beam shapes are distorted. Next we discuss the collection plan of weight of array feed.

## 2. Outline of LDRA

View of the large deployable reflector antenna (LDRA) is shown in Fig. 1. There are two LDRA's on ETS-VIII, one is transmitting antenna other is receiving antenna.

Physical size of reflector is 17 x 18 m, and Tx and Rx feeds constructed by S band phased array system are arranged at defocus points, 900 mm offset to

reflector surface direction from focus point, respectively. The reflectors are constructed by the metal mesh surface and the deployable truss structure, and stowed at launch and deploy on orbit [1].

Number of array elements of the Tx/Rx primary feed is 31, and 3 beams can be used at the same time.

Figure 2 shows the block diagram of beam forming network (BFN) of the transmitting array feed. Beam 1 (port 1) is independently controlled by arbitrary excitation of magnitude and phase, but beam 2 and 3 are uniformly controlled by the shared variable attenuators and the shared phase shifters. The shared attenuators and phase shifters are used for collection of beam pointing error caused by mechanical error

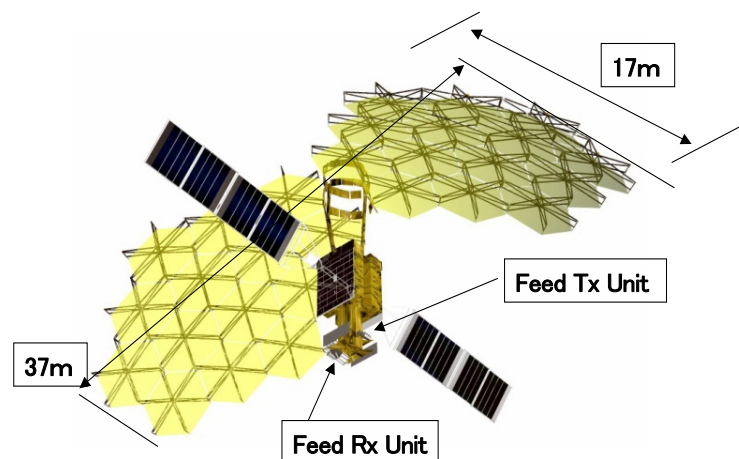

Fig. 1 View of LDRA

(such as satellite attitude error, reflector thermal distortion and other thermal distortion error)

BFN is controlled by beam forming controller (BFC). BFC calculates the array weight, controls the MMIC modules and interfaces with the telemetry and tracking control subsystem (TTC) of Satellite [2], [3], [4].

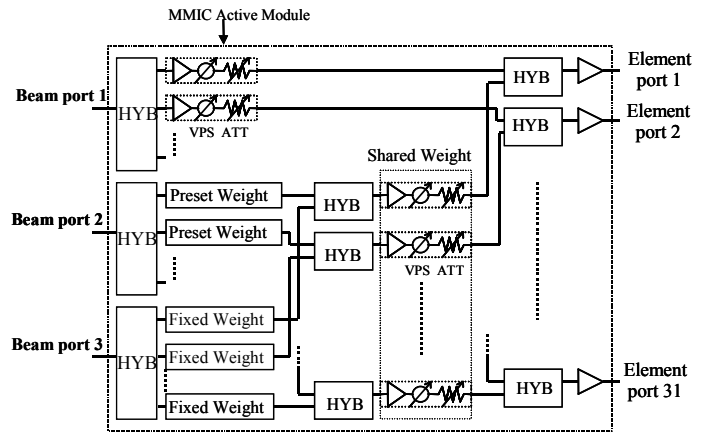

Fig. 2 Block diagram of BFN

### 3. Measurement of antenna pattern of LDRA

Figure 3 shows the typical beam allocation, Kyusyu-beam (#1), Shikoku-beam (#2), Toukai-beam (#3), Kanto-beam (#4) and Tohoku-beam (#5). Antenna patterns are measured by moving the satellite attitude with one dimension (cross scanning), and receiving the CW signal on the earth station from the transmitting antenna. In following discussion, we describe only the transmitting antenna. Locations of earth station for

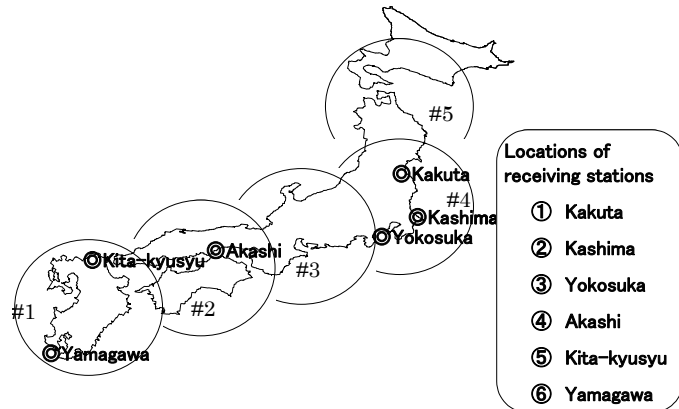

Fig. 3 Typical beam allocation

receiving CW signal from the satellite are ① Kakuta, ② Kashima, ③ Yokosuka, ④ Akashi and ⑤ Kita-kyusyu and ⑥ Yamagawa.

Measurement results shown as Fig.4 and 5. Where, Azimuth angle is corresponding to pitch angle of Satellite and Elevation angle is corresponding to roll angle. Upper graphs are calculated results using PO method and lower graphs are measurement results respectively. Comparing with the calculated results, measurement

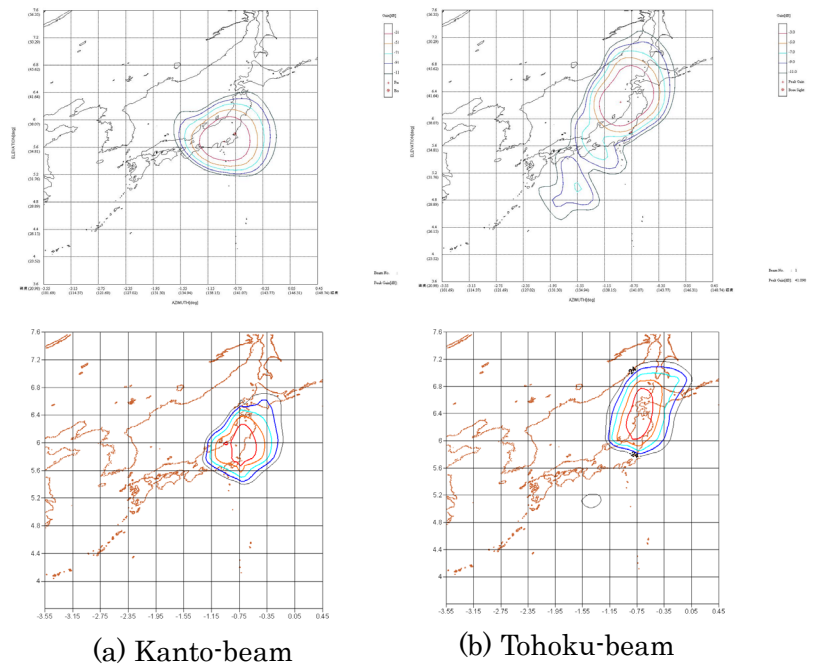

Fig. 4 Antenna pattern measurement results

pattern of the beam positions are little bit shifted and the beam shapes are little bit distorted. These results means need to correct the weight of array feed.

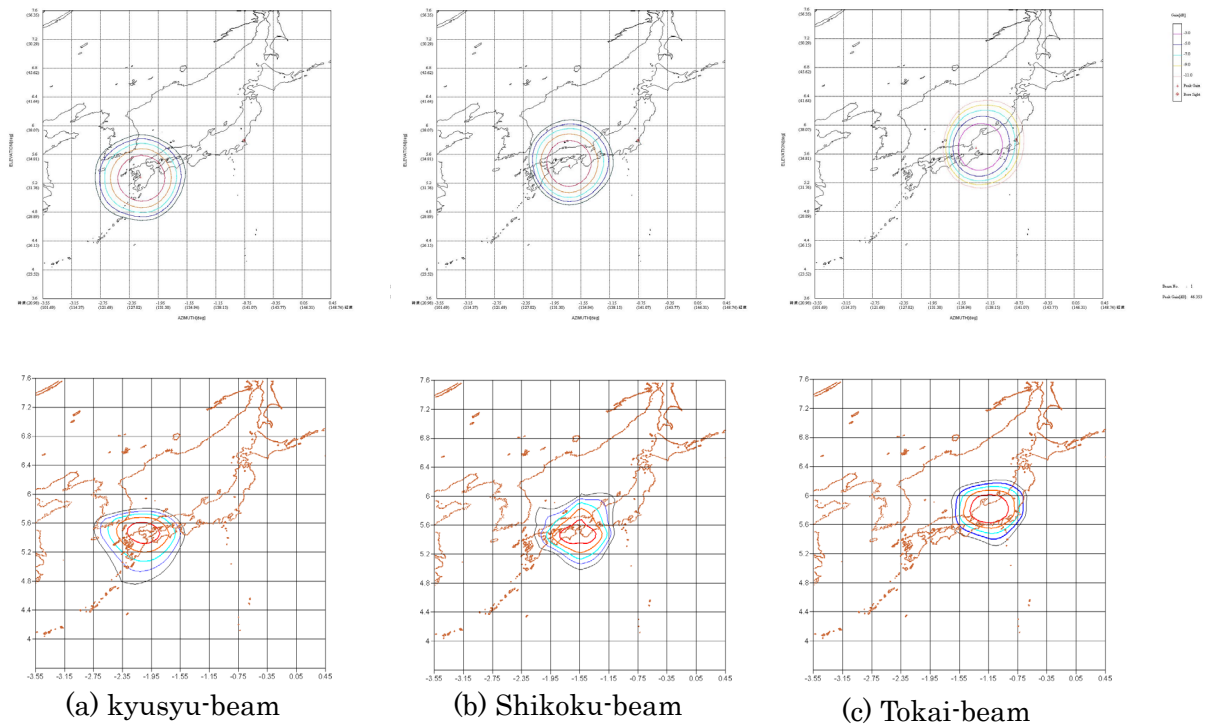

Fig.5 Antenna measurement results 2

#### 4. Experiment plan of weight correction of feed

We have next experiment plan to correct the weight of array feed, using the REV method (rotating element electric field vector method) [5]. Since the REV method dose not require the phase measurement of a received signal, it is suitable for evaluation of satellite passed array antenna on orbit [6]. But LDRA is the antenna combined the array feed with reflector. Then the other consideration will be needed. Figure 6 shows the secondary pattern of center element of feed at focus point combined with reflector and figure 7 shows the secondary pattern of off-focus feed. Contribution of array elements to the earth station is different respectively. For example, if earth station at 0.0 degree in

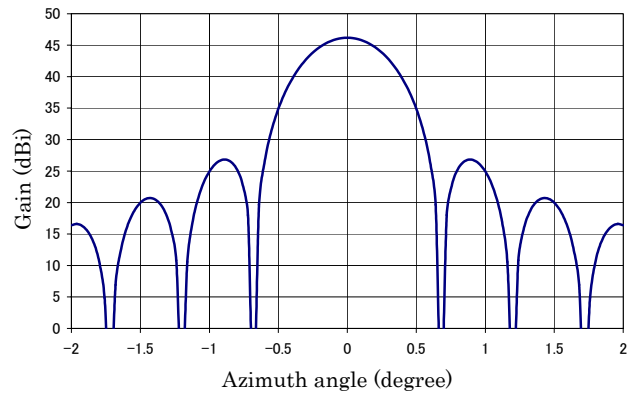

Fig. 6 Secondary pattern of center element on focus

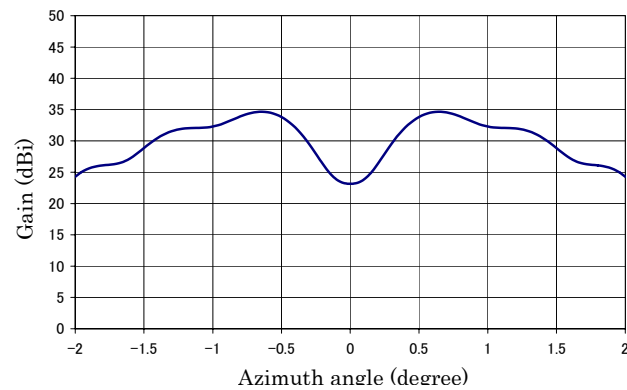

Fig. 7 Secondary pattern of center element off focus

Fig. 7, antenna gain excited by center element is about 23 dBi, on the other hand radiation pattern excited by adjacent element of center element is about 32 dBi in Fig.8. Then we consider the combination of array elements for using REV method. Measurement results by REV method will be evaluated by comparing with calculated results. Figure 9 is example of measurement result of REV method, dots are measurement points and solid line is cosine curve estimated by least squares method. Relative excited amplitude and phase of element is evaluated from this cosine function parameter. This result obtained from secondary pattern excited by only two elements, center element and other. From this, we confirmed the availability of REV method for LDRA. Then, we will collect the weights of all elements, in next experiment plan.

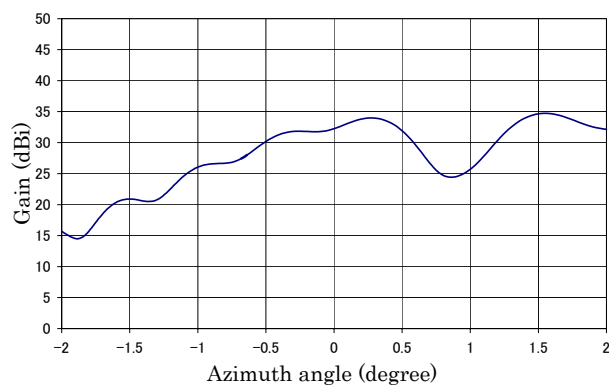

Fig.8 Secondary pattern of adjacent element of center off focus

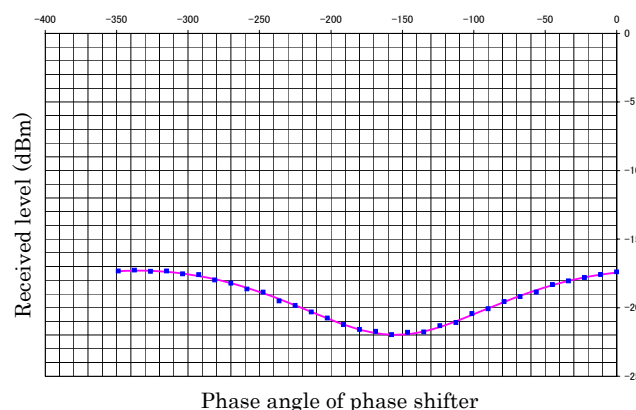

Fig. 9 REV measurement result using secondary pattern of two elements

## 5. Summary

Radiation pattern of typical beam of LDRA is measured by moving the attitude of satellite and compared to the calculated results. We recognize to collect the weight of array feed, then will experiment to collect the weight using REV method on orbit.

## References

- [1] K. Yonezawa and M. Homma, Journal of the national institute of information and communications technology, vol. 50, Nos. 3/4, pp.13-22. Sept/Dec. 2003
- [2] K. Ueno, Journal of the national institute of information and communications technology, vol. 50, Nos. 3/4, pp.57-66. Sept/Dec. 2003
- [3] Y. Matsumoto and M. Tanaka, Journal of the national institute of information and communications technology, vol. 50, Nos. 3/4, pp.67-72. Sept./Dec. 2003
- [4] Y. Matsumoto and T. Ide, Journal of the national institute of information and communications technology, vol. 50, Nos. 3/4, pp.73-83. Sept/Dec. 2003
- [5] S. Mano and K. Takagi, Trans. IEICE, vol. J65-B, No. 5, pp.555-560, 1982 (in Japanese)
- [6] T. Tanaka, Y. Matsumoto, S. Ymamoto, K. Suzuki and Y. Arimoto, Trans. IEICE, vol. J80B-II, No. 1, pp.63-72, 1997 (in Japanese)