

# The Influence of the Scattering Probe on the Measurement Results of Electromagnetic Fields by the Monostatic Modulated Scatterer Technique

Robert Vogt-Ardatjew<sup>1</sup>, Andrzej E. Sowa<sup>2</sup>

<sup>1</sup>University of Twente  
Enschede, The Netherlands  
r.a.vogtardatjew@utwente.nl

<sup>2</sup>Wroclaw University of Technology  
Wroclaw, Poland  
asowa@ieec.org

**Abstract**— In this paper, the influence of the scattering probe on the measurement results of electromagnetic fields, with the use of the Modulated Scatterer Technique (MST) has been evaluated. Three chosen characteristic locations of field distributions have been analyzed. The distance between the scatterer and an object located in its vicinity has been pointed out as a dominating factor causing the measurement error. The error value has been shown as a function of the mentioned distance. Additionally, the influence of the dipole scatterer size on the measurement error has been analyzed.

**Keywords**— monostatic MST, modulated scatterer technique, electromagnetic field, disturbance, computer simulation

## I. INTRODUCTION

The evaluation of the influence of the measurement probe presence on the electromagnetic field is an important measurement issue. This influence is usually negligible for far fields but can be critical for experiments in near fields [1]. The Modulated Scatterer Technique (MST) is a method of measuring electromagnetic fields featuring low invasiveness of the element placed in the field – the scatterer. This allows conduction of field measurements with small errors, related the presence of the measurement probe. The monostatic configuration of the MST, where the transmitting antenna serves also as the receiving one, is of particular interest. This configuration is proven to be convenient for field measurement in locations that are difficult to access when using classical field measurement methods. The most practical version of the monostatic MST is the OMS (Optically Modulated Scatterer) [2]. The negative influence of the cable on field disturbance is eliminated by substituting it with an optical fiber. The presented paper is aimed at the evaluation of the influence of the measurement probe presence on the field measurement results. The field distributions have been simulated and analyzed in case of presence and absence of the scatterer. The comparison has been carried out for the monostatic MST. A typical, symmetrical dipole scatterer was used. The evaluation of the influence of the scatterer on the field disturbance has been conducted in certain specific locations: free space, the vicinity of a metal reflective surface, and the vicinity of a dielectric pyramidal absorber with a complicated shape. The obtained results of the latter setup have been verified by experiments.

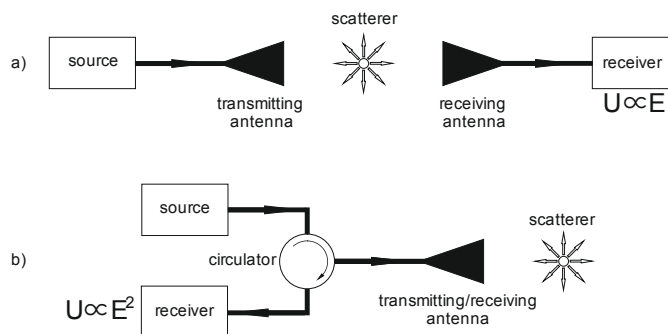

Fig. 1. Bistatic (a) and monostatic (b) MST configurations.  $E$  denotes the field strength at a position of the scatterer and  $U$  denotes the demodulated low frequency voltage - its frequency is equal to the modulating frequency of the scatterer.

## II. MONOSTATIC MST SETUP

The setups illustrating the ideas of the MST in the monostatic and bistatic configurations are presented in Fig. 1. The principles of their operation can be found in [3]. The characteristic advantage of the MST is the minimization of disturbance of the measured field caused by the probe itself. The reason for this is that only a scattering probe, in form of e.g. a simple dipole loaded with a simple modulating mechanism, is placed in the field. Simple build and low weight excludes the necessity of placing loads of field disturbing materials in it. Additionally, the small size allows the probe to penetrate places usually unreachable. The simplicity of the build and its small size derive directly from its function. The scattering probe does not process and does not send any signals. The information about measured field intensity is extracted from the signal that is reflected from the probe and received by the transmitting antenna (monostatic configuration) or the additional receiving antenna (bistatic configuration). In case of the OMS, both the modulating signal and supply power are sourced from within an optical fiber cable, which renders this link practically invisible in the field. In many cases, the MST can be much more convenient to use than the direct methods. The used measurement setup utilizes MST in the monostatic configuration. In this case, the demodulated low frequency voltage is proportional to the square of electric field at the position of the scatterer.

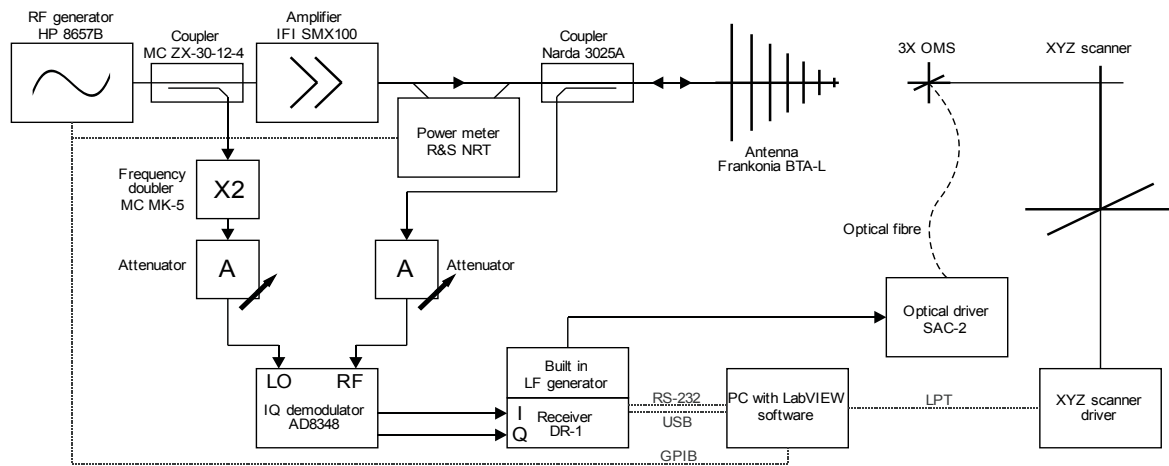

Fig. 2. The measurement setup

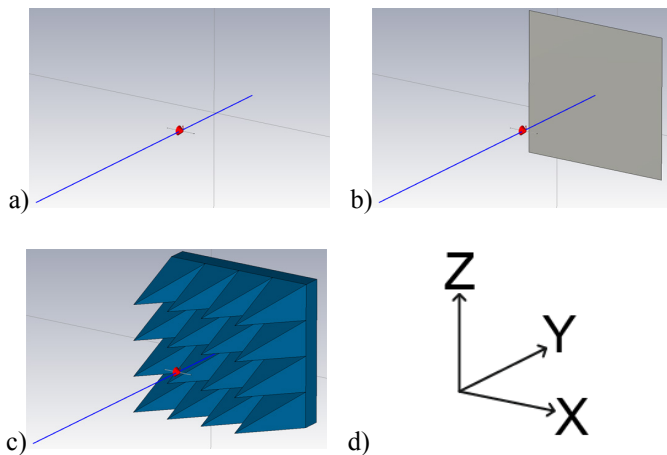

Fig. 3. Three field analysis locations: free space (a), metal plate (b), absorber backed by the metal plate (c) with marked antenna axis; coordinate system (d)

The setup is presented in Fig. 2 and is based on the setup described in [4]. By using an XYZ manipulator, it allows to scan the field in the range of 73 cm max in each axis. The chosen measurement distance increment in all cases was around 5 mm, controlled by counting the steps of a stepper motor. The whole setup is automated by software created in the LabVIEW environment. The scatterer is based on [5]. In the setup, the polarization of the antenna is parallel to the scattering dipole. The length of the scattering dipole is 12 cm, allowing measurements in the band ranging from 80 MHz up to 1 GHz [6]. In computer simulations, the scatterers with the lengths of 12 cm, 6 cm and 2 cm were used.

### III. TEST SITE DESCRIPTION

Field distribution has been analyzed in three particularly interesting locations: in free space, close to a metallic, reflective surface, and close to a dielectric pyramidal absorber with complicated spatial structure. All three selected characteristic arrangements are shown in Fig. 3. The reflective metal plate shaped like a 60 cm x 60 cm square was perpendicularly aligned to the direction of incident, linearly polarized wave. In the simulation, a perfect electrical

conductor was used to model the plate. The considered pyramidal absorber was a classical polyurethane foam absorber with a 34% graphite load. A single, typical block with the 61 cm x 61 cm (24"x24") base dimensions, 18" height, was backed by the previously described metallic plate. The absorber was modelled using electrical parameters found in [7]. The chosen scatterer is a symmetrical dipole placed on the plane perpendicular to the incident wave direction and parallel to the wave polarization vector. To evaluate the agreement between measurement and computer simulation results, numerical calculations using a commercial FDTD solver [8] have been conducted. All the setups were carefully associated to the corresponding models.

### IV. RESULT ANALYSIS

All the computer simulations and the measurements were executed at 1 GHz frequency. The 12 cm scatterer was used in the measurement part. A scatterer of the very same size was used for the computer simulation. Moreover, two additional dipoles of different lengths were modelled. The first one was two times shorter (6 cm), while the second one was six times shorter (2 cm) than the physical scatterer. The measurement scattering probe is a three axis probe [6], however, in the measurements only the dipole parallel to the transmitting antenna polarization was used. The field strength plot was computed as a function of the distance from the arbitrarily chosen point 0 cm. The reference 0 cm point was chosen on the surface of the reflective metal plate for both measurement and simulation.

#### A. Free space

The results of the computer simulation, for free space (open boundary conditions) field distribution without the scatterer (Fig. 3a), are shown in Fig. 4. In the same figure, the measurement results obtained in an anechoic chamber with the use of the 12 cm dipole scatterer are presented as well. The comparison of the results indicates only small differences between two plots resulting from the anechoic chamber imperfections. According to [1], in case of far field, probe size has no particular meaning for the measurement accuracy.

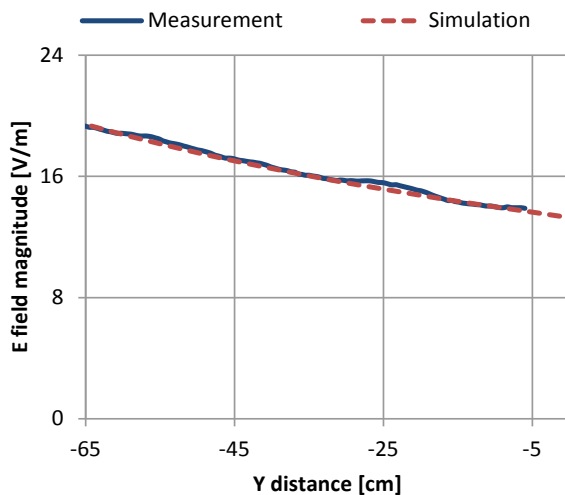

Fig. 4. Comparison of electric field magnitude measurement and simulation in the test zone, along antenna axis

However, the size has a substantial meaning for the sensitivity of the measurement setup, especially in case of the monostatic MST, characterized by the square relation between low frequency voltage and field strength. Therefore, the use of the scatterer with relatively large dimensions of the dipole (in our case  $0.4 \lambda$ ) is a preferred choice.

### B. Reflective metal plate

The results of the computer simulation for the configuration with the reflective metal plate (Fig. 3b) are shown in Fig. 5. The results are shown for the field distribution without the scatterer and including the 12 cm long dipole. While the field distribution along the antenna axis and without the scatterer can be obtained after a single simulation, the simulation including the dipole has to be conducted for each scatterer position. In this case, those positions were chosen to be in the antinodes of the created standing wave, where the absolute field strength is maximal. The relative error, expressed in %, resulting from the presence of the scatterer, referred to the case without the scatterer is shown in Fig. 6 as a function of the distance from the metal plate.

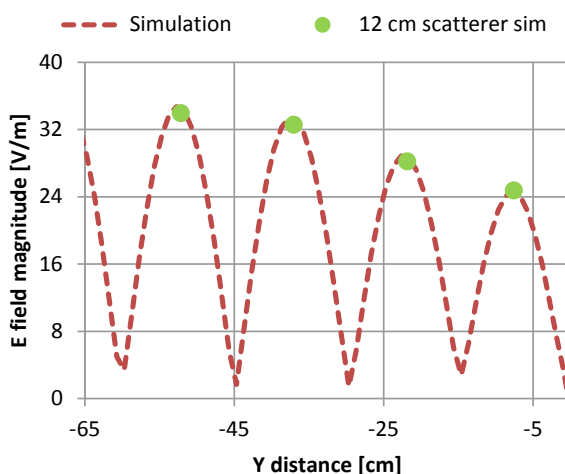

Fig. 5. Electric field magnitude simulation near the metal plate along antenna axis

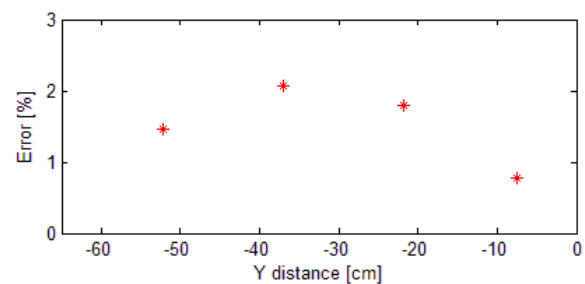

Fig. 6. Error resulting from the scatterer presence in the antinodes of the standing wave, next to the conductive plate

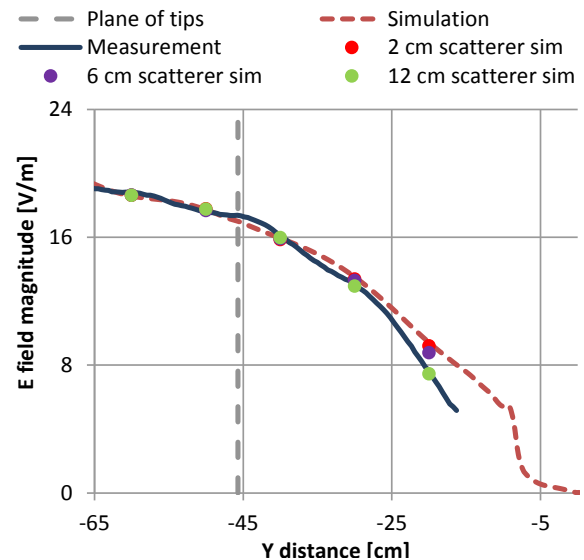

Fig. 7. Electric field magnitude measurement and simulations near the  $18^\circ$  absorber, along the antenna axis

### C. Pyramidal absorber

The results of the computer simulation for the configuration with the pyramidal absorber (Fig. 3c) are shown in Fig. 7. Apart from the field distribution in case of lack of the scatterer in the measurement space, simulations including scatterers of different lengths, i.e. 12 cm, 6 cm, and 2 cm, are shown as well. Additionally, the measurement results, obtained with a 12 cm scatterer are plotted in the same graph. The results comparison proves a very good agreement between all the computer simulations and the measurement in the region close to, and away from the tips of the absorber ( $Y < -40$  cm). This region can be compared to the result of the free space setup, shown in Fig. 4. With decreasing distance to the base of the absorber (towards reference 0 cm point) the spread between the obtained field values becomes greater. Beyond the plane of tips, i.e. when the probe is closely surrounded by the dielectric pyramids, the measurement results differ greatly from the simulated field distribution without the probe. They are, however, very similar to the results obtained by the simulation including a 12 cm scatterer, which is also the size of the scatterer used in the measurement. On the other hand, the simulation including a 2 cm scatterer produces field strengths that are almost the same as the values from the field distribution without a scatterer. Both comparisons prove high accuracy of the simulations.

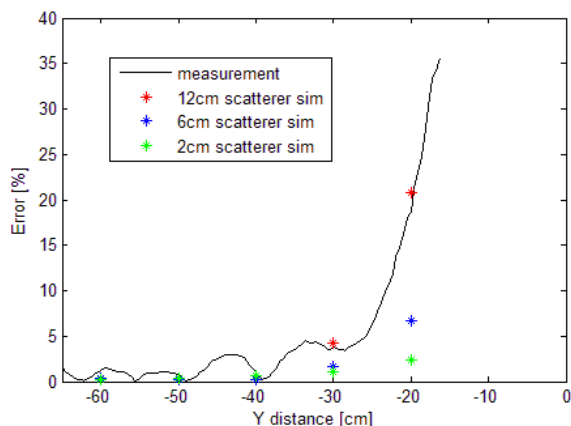

Fig. 8. Error resulting from the scatterer presence near the absorber

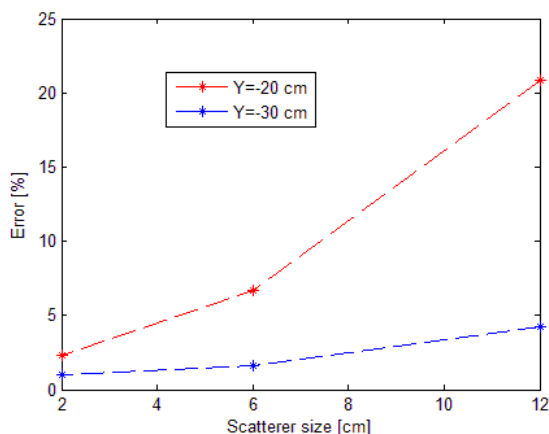

Fig. 9. Field measurement error vs. scatterer dipole length near the absorber

The plot of relative error, expressed in %, for all the analysed scatterer lengths, w.r.t. the simulated field distribution without any measurement probes, is presented in Fig. 8 and represents a very strong dependence on the distance from the object placed in the field. It can be concluded that the error reduction for a certain position of the scatterer is related to the length of the dipole. By reducing the length, however, the measurement setup sensitivity is lowered as well. The assumption of both the minimal accepted sensitivity of the measurement setup and the minimal distance from the absorber surface allows defining the minimal length of the dipole scatterer. This minimal length then defines the field measurement error caused by the scatterer presence in the measured field. Additionally, in Fig. 9, the field measurement error is shown as a function of the scatterer dipole length for two measurement points, closest to the absorber, where the error is the greatest. The chosen points are distanced 20 cm and 30 cm away from the 0 cm reference point. For the analyzed 18" pyramidal absorber, 20 cm from the backing plate means 1.5 cm from the closest absorber surface.

## V. CONCLUSIONS

This paper can make the useful reference for the evaluation of the field measurement error caused by the scatterer presence in field measurement by the monostatic MST. The evaluation of the scattering probe influence on the

measurement result of electromagnetic fields, by the monostatic MST, has been presented. Three characteristic scatterer locations were analysed:

### A. Free space

In free space the length of the scatterer, below  $0.5 \lambda$ , has practically no meaning for the measurement result. This conclusion agrees with [1], where the free space analysis was conducted in greater detail.

### B. Reflective metal plate

In case of measurements close to the reflective metal plate, the distance between the scatterer and this plate has a relatively small influence on the field measurement error. The measurement error caused by the presence of the 12 cm scatterer is not significant. Any error reduction requires decreasing of the dipole scatterer length. However, this strongly limits the sensitivity of the measurement setup.

### C. Pyramidal absorber

In case of field measurements close to the classical pyramidal absorber, made of polyurethane foam loaded with graphite, the distance between the scatterer and the surface of the absorber has an important impact on the field measurement error. This phenomenon depends on the dielectric material located in the near field of the scattering dipole. Such invasiveness in the near field can cause very high measurement errors. Strong dependence of the error on the dipole length has been shown. By reducing the dipole length, its near field region becomes smaller, therefore the disturbance caused by the surrounding objects becomes less significant. However, this also strongly limits the sensitivity of the measurement setup.

## REFERENCES

- [1] Wout Joseph, Luc Martens, "The Influence of the Measurement Probe on the Evaluation of Electromagnetic Fields", *IEEE Trans. Electromagn. Compat.*, vol. 43, No. 2, May 2003, pp. 339-349.
- [2] G. Hygate, J. F. Nye, "Measuring Microwave Fields Directly With An Optically Modulated Scatterer", *Meas. Sci. Technol.*, vol. 1, pp.703-709, 1990.
- [3] J. -C. Bolomey, F. E. Gardiol, *Engineering Applications of the Modulated Scatterer Technique*. Norwood: Artech House, MA 2001.
- [4] Vogt-Ardatjew, R.; Sowa, A.E., "Experimental field mapping in direct vicinity of a pyramidal absorber using Modulated Scatterer Technique," *Electromagnetic Compatibility (EMC EUROPE), 2012 International Symposium on*, vol., no., pp.1,6, 17-21 Sept. 2012.
- [5] A.E. Sowa, J. S. Witkowski, B. Paszkiewicz, I. Zborowska- Lindert, "Optical System for Electromagnetic Field Measurement using Modulated Scattering Technique", *Optica Applicata*, Vol.XXXIV, No.2 2004, pp 229-239.
- [6] A. E. Sowa, J. S. Witkowski, "Field calibration system implementing 3-D optically modulated scatterers for immunity test site purposes." *IEEE Trans. Electromagn. Compat.*, vol. 46, pp. 648-654, Nov. 2004.
- [7] C.L. Holloway, R.R. DeLyser, R.F. German, P. McKenna, M. Kanda, "Comparison of electromagnetic absorber used in anechoic and semi-anechoic chambers for emissions and immunity testing of digital devices," *Electromagnetic Compatibility, IEEE Transactions on*, vol.39, no.1, pp.33-47, Feb 1997.
- [8] CST Microwave Studio [Online]. Available: <http://www.cst.com>.