

Experimental results on 4×4 MIMO precoding in E-UTRA

Yoshiaki Ofuji, Naoto Okubo, Sadayuki Abeta, and Takehiro Nakamura
 Radio Access Network Development Department, NTT DOCOMO, INC.
 3-5 Hikari-no-oka, Yokosuka-shi, Kanagawa-ken, 239-8536 Japan

Abstract- This paper presents experimental results on MIMO multiplexing and MIMO diversity using precoding for OFDMA radio access in the Evolved UTRA downlink. In the evaluations, we compare throughput performance of 4×4 MIMO with 1 to 4-stream transmission for various modulation and channel coding scheme (MCS) set to clarify the selection criteria for the number of streams on rank adaptation as the function of received E_s/N_0 and fading correlations between antennas. Based on the evaluations, we concluded that throughput is maximized by using 3 or 4-stream transmission at the almost all region of received E_s/N_0 excepting the low received E_s/N_0 region less than 2 dB. Furthermore, the optimum combinations of the number of streams and MCS are identical when the antenna correlation is lower than 0.7. However, the switching points of received quality (E_s/N_0) on the combinations of the number of streams and modulation scheme is shifted by 2 to 5 dB in case of fading correlation, $\rho=0.5$ and 4 to 8 dB in case of $\rho=0.7$ are compared to those in $\rho=0$.

I. INTRODUCTION

3G Long term evolution (LTE) has been extensively discussed under the 3GPP standardization and the core specifications were approved at the end of 2007. The Evolved UTRA Terrestrial Radio Access (E-UTRA) [1], which is radio access system in 3G LTE, is able to support full IP-based functionalities with low latency and low cost. In a channel bandwidth wider than 5 MHz, which is the main interest in the E-UTRA, multipath interference (MPI) impairs the achievable data rate and coverage. Thus, orthogonal frequency division multiplexing (OFDM) based radio access was adopted in the downlink in order to mitigate the increasing MPI. In the E-UTRA downlink, the following key techniques, which are appropriate to packet-based radio access, are adopted: adaptive modulation and channel coding (AMC), hybrid automatic repeat request (HARQ) with packet combining, frequency and time domain channel-dependent scheduling, and multiple input multiple output (MIMO).

Among above techniques, MIMO is the key technique to support the peak data rate above 100Mbps which is one of the important requirements in the LTE and increase system capacity. There are several MIMO schemes such as MIMO multiplexing (a.k.a. spatial multiplexing(SM) - MIMO) and MIMO diversity (a.k.a., space time (or frequency) transmitter diversity). It is well known that MIMO multiplexing performs well in the higher signal-to-interference plus noise

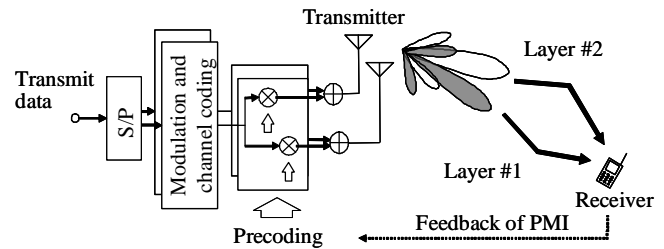

Figure 1. Closed-loop type precoding MIMO transmission.

power ratio (SINR) region and in the scattered channel environment to improve the bit rate. On the other hand, MIMO diversity performs well under all the channel condition, however, with lower bit rate. Some literatures investigated the optimum switching scheme between MIMO multiplexing and MIMO diversity (so called rank adaptation) in two-antenna case [2], [3].

The switching scheme for 4×4 MIMO, however, has not been well investigated. In 4×4 MIMO, the selection criteria for the number of streams more than 2 and modulation and coding scheme (MCS) is necessary in addition to the selection criteria on MIMO multiplexing and MIMO diversity with 2 antennas. Moreover, selection criteria for the number of streams may be different from the 2 antenna case since receiver diversity gain in 4×4 MIMO is higher than that in 2 antenna case. Therefore, this paper investigates the selection criteria for the number of streams in case of 4×4 MIMO with experimental system with E-UTRA air-interface. The rest of the paper is organized as follows. First, Section II describes the MIMO precoding scheme, which generates a user-dependent transmission beam pattern based on the instantaneous channel gain that is fed back from a user equipment (UE), and rank adaptation. Then, the experimental system and laboratory test configuration are given in Section III. Subsequently, the test results are presented followed by our conclusions.

II. PRECODING MIMO AND RANK ADAPTATION

The configuration of closed loop type MIMO precoding scheme is illustrated in Fig. 1. In MIMO precoding, the user-specific transmission beam is generated based on the channel information to maximize the received SINR. The optimal

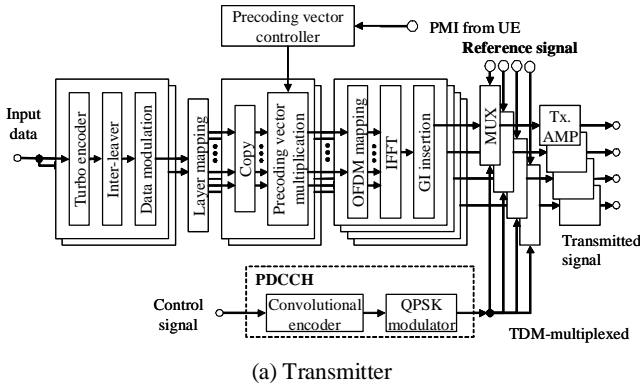

(a) Transmitter

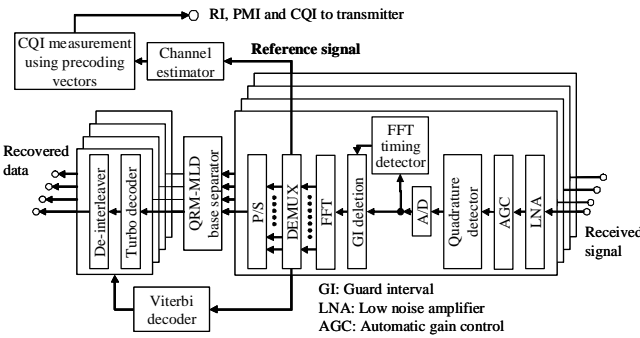

(b) Receiver

Figure 2. Configuration of implemented experimental system.

precoding scheme is singular vector decomposition which requires complete channel knowledge. However, it is not practical to inform the huge information in the feedback channel. Therefore, a quantized beamforming technique maximizing received SINR was proposed where the receiver only sends the label of the best beamforming vector in a predetermined codebook to the transmitter [4][5]. In this scheme, the receiver estimates the received SINRs by multiplying the channel information measured by reference signal and precoding vectors. Then, the best precoding vector among the precoding vectors in codebook is chosen at the receiver. In E-UTRA, this precoding vector is called as precoding matrix indicator (PMI). The receiver also estimates the channel state information, so called channel quality indicator (CQI) which is used to select the MCS at the transmitter. The receiver sends both PMI and CQI to transmitter in a certain period.

In non-correlation channel, the codebook proposed in [4], [5] is the optimum scheme. However, fading correlation between transmitter/receiver antennas varies in the real channel. Thus, the cookbook based on the Householder is applied as the E-UTRA precoding codebook [6].

Using the estimated number of ranks of channel and received SINR derived using the precoding vector, the receiver estimates the achievable data rate. For example, the

TABLE I Major Radio Link Parameters

System bandwidth		20 MHz
Number of sub-carriers		1200 (15 kHz sub-carrier separation)
OFDM symbol duration		66.7 μ sec + CP 4.7 μ sec
Sub frame length		1.0 msec
PDSCH	Data modulation	QPSK, 16QAM, 64QAM
	Channel coding / Decoding	Turbo code ($R = 0.16$ to 0.82) / Max-Log-MAP decoding
PDCCH	Data modulation	QPSK
	Channel coding / Decoding	Convolutional code ($R = 1/3$) / Soft-decision Viterbi decoding
Number of transmitter/receiver antennas		4 / 4

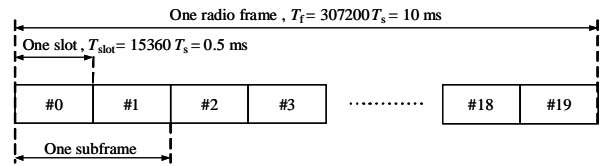

Figure 3. Frame format in downlink.

achievable data rate can be calculated as $r = M \times \log_2(I + \gamma)$, where M is the number of ranks and γ is the estimated SINR. However, the MCSs are limited and achievable data rate is different from Shannon formula in actual system. Thus, data rate is estimated by using the lookup table which is pre-installed at the receiver. We also need decision criteria if the achievable data rate is the same for different ranks. Then rank indication (RI), which indicates the number of ranks, is determined to achieve the highest data rate. The RI is informed from receiver to transmitter together with the PMI and CQI. For example, if a UE feed back the RI of 3, transmitter performs 3-stream transmission to the UE. The paper investigates the selection criteria for the number of streams based on the experimental results in section IV.

III. CONFIGURATION OF LTE EXPERIMENTAL SYSTEM

A. Transmitter and receiver configuration

The configuration of the base station (called evolved Node B (eNB) in E-UTRA) transmitter and UE receiver and the major radio link parameters are given in Figs. 2 (a), (b) and Table I, respectively. The total bandwidth and the number of sub-carriers of the OFDM signal in the downlink are 20 MHz (include 2-MHz guard band) and 1200 (= 100 resource blocks (RBs)), respectively (thus, the sub-carrier separation is 15 kHz). The frame format in the downlink is shown in Fig. 3. The length of the slot and sub-frame is 0.5 msec and 1 msec, respectively.

In the eNB transmitter, first, an input information bit sequence is divided into two code words when the number of

TABLE III Modulated data sequence to layer mapping

Number of layers	Modulated data -to-layer mapping
1	$x^{(0)}(i) = d^{(0)}(i)$
2	$x^{(0)}(i) = d^{(0)}(i), x^{(1)}(i) = d^{(1)}(i)$
3	$x^{(0)}(i) = d^{(0)}(i),$ $x^{(1)}(i) = d^{(1)}(2i), x^{(2)}(i) = d^{(1)}(2i+1)$
4	$x^{(0)}(i) = d^{(0)}(2i), x^{(1)}(i) = d^{(0)}(2i+1)$ $x^{(2)}(i) = d^{(1)}(2i), x^{(3)}(i) = d^{(1)}(2i+1)$

streams is larger than two. The divided information bit sequences are serial-to-parallel converted, then, each sequence is turbo encoded using the coding rate of R with the constraint length of four bits. The variable channel coding rates are generated by puncturing the parity bits in the encoding sequence of $R = 1/3$, then data modulation mapping is performed. The modulated data sequences $d^{(p)}(i)$ ($p=0,1$) are re-mapped onto one or several layer $x^{(q)}(i)$ at layer mapping stage, where q is the number of parallel sequences, which is equal to the number of ranks. The modulated data sequence to layer mapping is summarize in TABLE II. After layer mapping, the modulated data sequence $x^{(q)}(i)$ are multiplied by the precoding vector which is informed via Physical uplink control channel (PUCCH). Finally, precoded data sequences are mapped to the physical downlink shared channel (PDSCH). Subsequently, the physical downlink control channel (PDCCH) which informs of the PMI, RB allocation, MCS, and redundancy version (RV) are time-multiplexed at the first OFDM symbols in the sub-frame. The reference signals (RS)s used for channel estimation and received SINR measurement are scattered mapped onto the time-frequency domain in one sub-frame [7]. RSs of different transmitter antenna are frequency-multiplexed. After inverse fast Fourier transform (IFFT), the guard interval (GI) is added at the beginning of each OFDM symbol. Finally, the IF modulated signal is up-converted into the RF signal and amplified by the power amplifier.

At the UE receiver, the frequency down-converted IF signal from each receiver antenna is linearly amplified by an automatic gain control (AGC) amplifier. The received signals at receiver antennas are converted into baseband in-phase (I) and quadrature (Q) components by a quadrature detector. The I and Q signals are converted into digital format by A/D converters. After detecting the fast Fourier transform (FFT) timing by using RSs, GI is removed and parallel data sequences are de-multiplexed by FFT processing from the multicarrier signal. The channel gain is estimated by RSs mapped into time-frequency domain within a sub-frame. Spatial multiplexed signals transmitted from different transmitter antennas are separated using QRM-MLD with ASSES [9] based signal separator. UE detects the all allocated RBs and MCS by decoding PDCCH. With the information, turbo decoding is performed to recover the information bit sequence (Max-Log-MAP decoding).

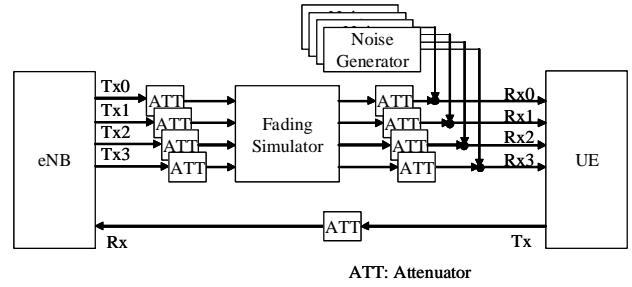

Figure 4. Laboratory experimental configuration.

Meanwhile, by multiplying the precoding vector in codebook to the channel gain, optimum precoding vector is selected, then, CQI with selected precoding vectors is calculated. Obtained PMI and CQI value are sent to the transmitter by the physical uplink control channel (PUCCH). In uplink, we employed single-carrier FDMA (SC-FDMA) [7]

B. Laboratory test configuration

The experimental configuration is illustrated in Figure 4. The experimental system supports 2×2 and 4×4 MIMO configurations. The downlink signals from different outputs of transmitter are first fed into the fading simulator which emulates the MIMO channel. We assume the extended vehicular A (EVA) channel model which consists of 9 paths with the root mean square delay spread of $0.357 \mu\text{s}$. The maximum Doppler frequency is set to 5Hz and fading correlation ρ is set to 0, 0.5 and 0.7. The definition of fading correlation is following. The correlation between any antennas is same value in both transmitter and received antennas. Gaussian noise is added at the UE receiver input as background noise.

C. Precoding MIMO and PMI reporting scheme

In the experiments, Householder-based codebook is used. The codebook is identical to E-UTRA codebook [7]. Common precoding vector is used for all sub-carriers since the gain of frequency selective precoding is marginal [9]. CQI, PMI and RI calculated at UE are transmitted via PUCCH. The reporting period of CQI, PMI and RI is set to 18 msec and feedback delay of each indicator is 3 msec.

IV. EXPERIMENTAL RESULTS

A. Evaluation on optimum set of the number of streams and MCS

The optimum combination between the number of streams and MCS varies according to the received SINR and fading correlation. We first clarify the relationship between achievable throughput and average received signal energy per symbol-to-background noise power spectrum density ratio (E_s/N_0) and fading correlation. Thus, we employ the fixed number of streams and fixed MCS in

TABLE III Combinations of rank and MCS

Transmission rate	1-stream	2-stream	3-stream	4-stream
36 Mbps	16QAM $R = 0.73$	QPSK $R = 0.73$	QPSK $R = 0.49$	QPSK $R = 0.37$
60 Mbps	64QAM $R = 0.81$	16QAM $R = 0.61$	QPSK $R = 0.81$	QPSK $R = 0.61$
84Mbps		64QAM $R = 0.57$	16QAM $R = 0.57$	16QAM $R = 0.43$
108Mbps		64QAM $R = 0.73$	16QAM $R = 0.73$	16QAM $R = 0.55$
132Mbps			64QAM $R = 0.60$	16QAM $R = 0.67$
156Mbps			64QAM $R = 0.70$	16QAM $R = 0.79$
180Mbps			64QAM $R = 0.81$	64QAM $R = 0.61$

the following evaluations, i.e. no rank adaptation and no AMC is applied. However, we apply closed-loop precoding scheme to generate UE-specific transmission beam. To find the best combination of the number of streams and MCS, we evaluate the throughput performance with various combinations shown in Table III. For instance, the data rate of 108 Mbps can be achieved with the combination of 64QAM with $R = 0.57$ in 2-stream, 16QAM with $R = 0.57$ in 3-stream and 16QAM with $R = 0.43$ in 4-stream. The other parameters are set to fixed value below for simplifying the test. The number of allocated RBs for PDSCH is set to 88 and the maximum number of retransmission in HARQ is set to 3.

The average throughput performances employing the various combinations between MCS and the number of streams are plotted in Figs. 5 to 7 as a function of the average received E_s/N_0 per receiver branch.

Figure 5 shows the throughput performances for the fading correlation of $\rho = 0$. In the Fig. 5, throughput is maximized by using 3 or 4-stream transmission at the almost all region of received E_s/N_0 , though at the low E_s/N_0 region like less than 2 dB, the combination of QPSK with 2-stream transmission is optimum. This can be explained in following. The gain from MIMO diversity in 1 and 2-stream transmission is not significant since large diversity gain is obtained even in 3 or 4-stream transmission thank to the 4 received antennas in 4x4 MIMO with MLD based detector in non-correlated channel. According to the increase in received E_s/N_0 , optimum combinations of the number of streams and modulation scheme changes as following order; QPSK with 2-stream, QPSK with 3-stream, QPSK with 4-stream, 16QAM with 3-stream, 16QAM with 4-stream, 64QAM with 3-stream. At the high E_s/N_0 region such that achievable throughput greater than 180 Mbps, we must select 64QAM with 4-stream in order to achieve high transmission rate.

Figure 6 shows the throughput performances in fading correlation of $\rho = 0.5$. Since the performance degrades in higher order of streams due to poor accuracy on signal decomposition at the receiver, operating range of the combinations of 16QAM with 4-stream transmission is small compared to the case of $\rho = 0$. The

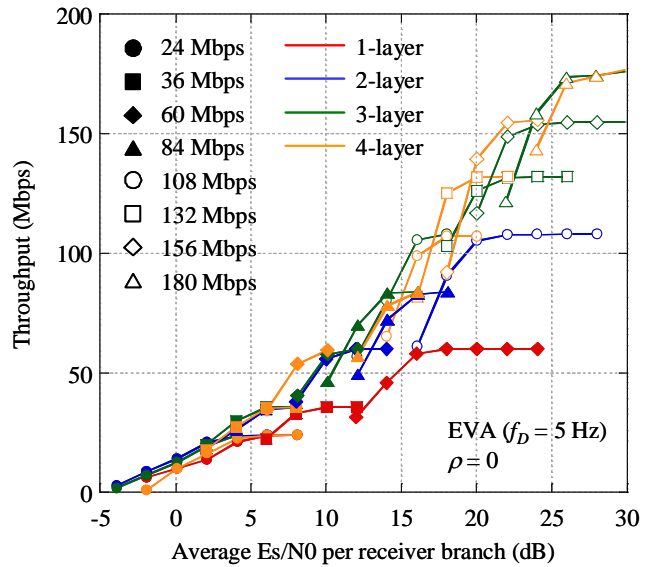

Figure 5. Comparison on throughput performances with antenna correlation of $\rho = 0$.

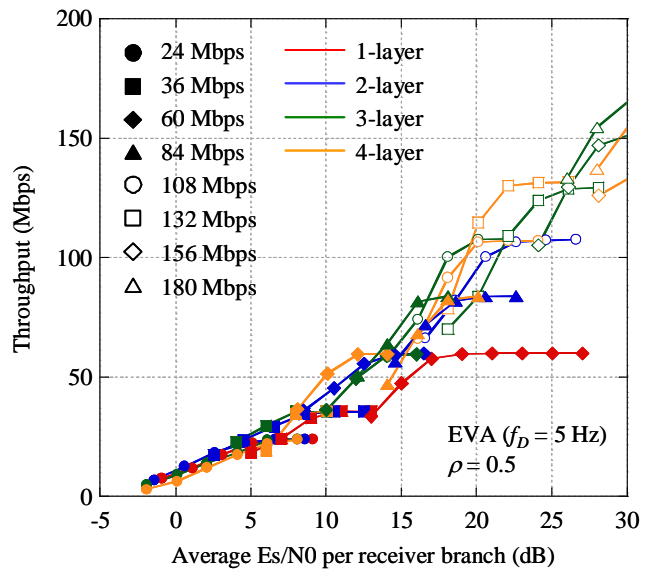

Figure 6. Comparison on throughput performances with antenna correlation of $\rho = 0.5$.

optimum combinations of the number of streams and modulation which maximize throughput at each received E_s/N_0 region are almost the same as in $\rho = 0$, though the received E_s/N_0 at the changing points of combinations of the number of streams and modulation are 2 to 5 dB higher than these in $\rho = 0$. The difference of the changing points increases according to the transmission rate.

Figure 7 shows the throughput performances in fading correlation of $\rho = 0.7$. When $\rho = 0.7$, achievable throughput is at most 132 Mbps, and there is no operating range of 64QAM. The received E_s/N_0 at the changing points of optimum combinations of

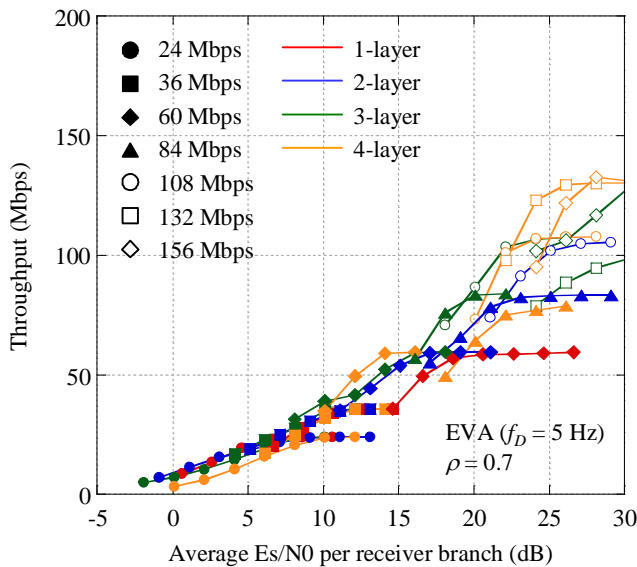

Figure 7. Comparison on throughput performances with antenna correlation of $\rho = 0.7$.

the number of streams and modulation are approximately 2 to 3 dB higher than these in $\rho = 0.5$.

B. Strategy of number of rank and MCS selection

From the performances in Figs. 5 to 7, it seems that we can select the sub-optimum combination of the number of streams and MCS by such the way as follows according to the received E_s/N_0 and fading correlation.

- Basically, according to the decrease in received E_s/N_0 , reduce the number of stream first, next modulation order.
- However, there is no operating range of 1 and 2-stream transmission for 64QAM and 16QAM.
- The optimum combinations of the number of streams and modulation scheme are the same irrespective of fading correlation.
- However, even though the same received E_s/N_0 per receiver branch, when the fading correlation is large we should select the small number of streams at the same time select the MCS of low transmission rate.

V. CONCLUSION

The experimental results on the MIMO multiplexing and MIMO diversity using precoding for OFDMA radio access in the Evolved UTRA downlink were evaluated. We compared throughput performances for various MCS set to clarify the selection criteria for number of streams on rank adaptation taking into account the received E_s/N_0 and the fading correlations between antennas. The results are that throughput is maximized by using 3 or 4-stream transmission at the almost all

region of received E_s/N_0 excepting the low received E_s/N_0 region less than 2 dB. Furthermore, the optimum combinations of the number of streams and modulation order are independent on fading correlation. However, the changing points of combinations of the stream and modulation in fading correlation, $\rho = 0.5$ ($\rho = 0.7$) are 2 to 5 dB (4 to 8) higher than these in $\rho = 0$.

REFERENCES

- [1] 3GPP, TR-25.814 (V7.1.0), "Physical layer aspects for Evolved UTRA"
- [2] R. W. Heath Jr. and A. Paulraj, "Switching between diversity and multiplexing in MIMO systems," *IEEE Trans. Commun.*, vol. 53, no. 6, pp.962-968, June 2005.
- [3] S. Choi, Y. Ko, E. J. Powers, "Optimization of Switched MIMO Systems Over Rayleigh Fading Channels", *EEE Trans. VT.*, vol. 56, no. 1, pp.103-114, Jan. 2007.
- [4] D.J. Love, R.W. Health, Jr., and T. Strohmer, "Grassmannian beamforming for multiple-input multiple-output wireless systems," *IEEE Trans. Inf. Theory*, vol. 49, no. 10, Oct. 2003. pp. 2735-2747.
- [5] D. J. Love and R. W. Heath Jr., "Limited Feedback Unitary Precoding for Spatial Multiplexing Systems," *IEEE Transactions Information Theory*, vol. 51, pp. 2967-2976, Aug. 2005.
- [6] 3GPP, R1-072844, "Link Level Evaluation of 4-TX Codebook for SU-MIMO," June 2007
- [7] 3GPP, TS-36.211 (V8.3.0), "Physical Channels and Modulation," May 2008.
- [8] 3GPP, TS-36.213 (V8.3.0), "Physical layer procedures," May 2008.
- [9] K. Higuchi, H. Kawai, N. Maeda, and M. Sawahashi, "Adaptive selection of surviving symbol replica candidates based on maximum reliability in QRM-MLD for OFCDM MIMO multiplexing," in *Proc. IEEE Globecom2004*, vol. 4, 2480-2486, Nov. 2004.
- [10] 3GPP, R1-073707, "Investigation on Frequency Granularity of SU-MIMO Precoding in E-UTRA Downlink" August 2007