

# Performance of Wavelength Exchange in Anomalous-dispersion Region

Rebecca W. L. Fung, Henry K. Y. Cheung, and Kenneth K.Y. Wong

Department of Electrical & Electronic Engineering, The University of Hong Kong, Pokfulam Road, Hong Kong.

E-mail: [wlfung@eee.hku.hk](mailto:wlfung@eee.hku.hk)

**Abstract:** We demonstrate the 10Gb/s wavelength exchange with two pumps at the anomalous-dispersion region. Extinction ratio between converted signal and residual signal is ~20dB. Bit error rate of  $<10^{-9}$  is achieved with power penalty of ~2dB.

## I. Introduction

Wavelength exchange (WE) relying on four-wave mixing (FWM) in highly nonlinear dispersion-shifted fibers (HNL-DSF) has been studied in recent research. Previously, simultaneous conversion of two signals can be achieved by a suitable choice of wavelengths of two pumps at the normal dispersion region and the two signals at the anomalous region with respect to the zero-dispersion frequency  $\omega_0$  of a fiber (denoted as WE I) [1]. Past results showed that the pump induced Raman amplification introduces asymmetric power transfer that degrades the performance of the WE I process. Such performance degradation is particularly severe when the two pumps are arranged orthogonally at the normal dispersion region [2]. Therefore, we have proposed another configuration with two pumps at the anomalous dispersion regime (denoted as WE II), where the performance degradation caused by Raman gain can be eliminated [3]. In theory, no Raman gain is provided by pumps allocated at anomalous dispersion region, so it can predict power transfer asymmetry can be avoided in WE II [3]. With this arrangement, signals at the normal dispersion region exhibit symmetric power transfer characteristics and a nearly-complete wavelength exchange can be achieved. In this paper, we demonstrate an experimental validation of WE II with two 10Gb/s  $2^7-1$  pseudo-random bit sequence (PRBS) signals. The performance of the exchanger is quantified by the measurements of eye diagrams and bit error rate (BER).

## II. Experiment

The experimental configuration is shown in Fig.1. The wavelength exchanger consisted of 1 km of HNL-DSF with a zero-dispersion wavelength  $\lambda_0$  of 1540nm, a dispersion slope of 0.03ps/nm<sup>2</sup>km and a fiber non-linearity coefficient  $\gamma$  of 12W<sup>-1</sup>km<sup>-1</sup>. The two tunable laser sources, TLS1 and TLS2, were set at 1549nm and 1554nm respectively, served as the two pumps. They were phase-modulated (PM) by a 10Gb/s  $2^7-1$  PRBS [4] to suppress stimulated Brillouin scattering (SBS). The erbium-doped fiber amplifier (EDFA 1) served as the

preamplifier to a booster EDFA 2, with a maximum output power of 33dBm. The two tunable bandpass filters (TBPF) with 2nm bandwidth were inserted after EDFA 1 so as to filter out the two pumps separately and reduce amplified spontaneous emission (ASE) noise. Two polarization controller (PC 3 & PC 4) were used to control the state of polarization (SOP) of the two pumps such that orthogonal pump configuration can be maintained by minimizing the power of the spurious FWM components. The exchange efficiency can be higher with using orthogonal pump allocation [5]. The SOP of each pump was adjusted by PC 1 & PC 2 while PC 5 & PC 7 were adjusted to minimize the insertion losses to the PM and amplitude modulator (AM), respectively. Wavelengths of the tunable laser sources, TLS3 and TLS4, were chosen at 1534 and 1529nm, respectively, which were served as signals. They were intensity-modulated with a 10Gb/s  $2^7-1$  PRBS. A variable optical attenuator (VOA) was inserted after EDFA 2 to adjust the input pump powers. A 95/5 coupler combined 95% of the two pumps and 5% of the signal into the fiber. The output power from the fiber was sent to the optical spectrum analyzer (OSA) to display the spectrum after the exchange. The waveforms and BER were measured using the digital communication analyzer (DCA) and BER tester, respectively.

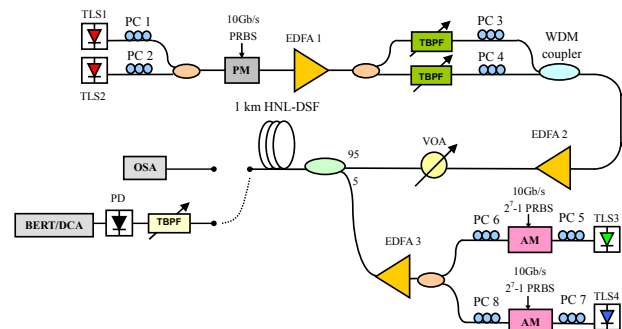

Fig. 1. Experimental setup of the wavelength exchanger.

## III. Results and Discussion

It has been discussed that pump-induced Raman amplification will cause asymmetric power transfer at the normal dispersion region. Therefore, orthogonal WE II is introduced to improve the symmetry of WE [3]. The experimental result of orthogonal WE II is shown in Fig. 2. The experimental result demonstrates that symmetric power transfer characteristics can be obtained from WE II such that the maximum power of the idler (generated

at 1529nm) can be attained together with the minimum power of the residue signal. The maximum normalized idler power is equal to unity in the WE process as no Raman gain is provided by the two pumps. Result shows that a nearly complete WE can be obtained.

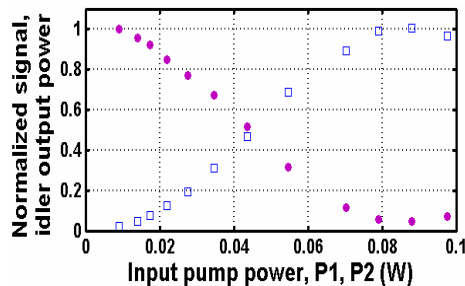

Fig. 2. WE transfer characteristics in WE II with signal at 1534nm and idler at 1529nm – signal power (●) and idler power (□) [3].

During the practical WE, two signals placed at 1534 and 1529nm undergo exchanging process simultaneously. Under the process, the two corresponding idlers were generated at 1529 and 1534nm accordingly. Extinction ratio (ER) was defined as the power ratio between the maximum converted signal (idler) and the minimum residual signal [2]. Here, the ERs were measured to be ~20 dB in both cases after WE as shown in Fig. 3.

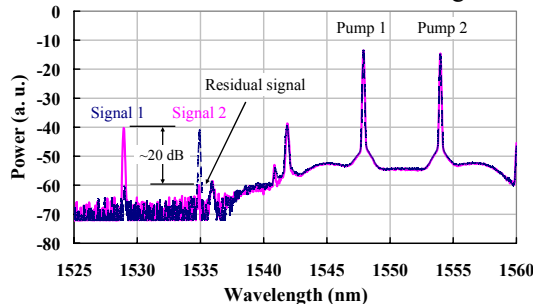

Fig. 3. Measured optical spectra after WE.

Both signals are modulated with 10Gb/s  $2^7-1$  PRBS. Figure 4(a) and (b) represent the original signal waveforms before WE observed at 1534 and 1529nm, respectively. The insets show their eye diagrams with Q-factor of 10dB and 10.4dB, respectively.

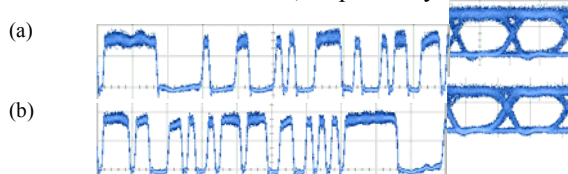

Fig. 4. Data stream observed (a) at 1534nm (b) at 1529nm before WE.

The exchanged signals after WE observed at 1534 and 1529nm are shown in Fig. 5(a) and (b), respectively. The two figures illustrate that the original signal at 1529nm is efficiently exchanged to its corresponding idler wavelength at 1534nm while the original signal at 1534 nm is exchanged to its idler wavelength at 1529nm, indicating that WE II is successfully achieved. The insets show their eye diagrams with Q-factor of 9.1dB and 9.5dB, respectively. However, the data after WE is noisy because the noisy mark level is caused by the EDFA

ASE noise from the two pumps. It is suggested that the ASE noise of the pump can be suppressed by a fiber-Bragg grating (FBG) with a narrow bandwidth and a high suppression level [5].

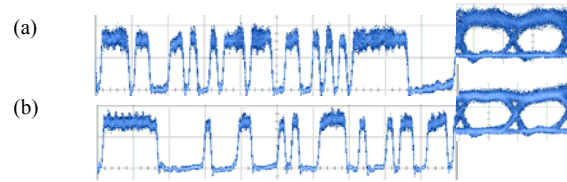

Fig. 5. The exchanged signal (a) at 1534nm (from 1529nm to 1534nm) (b) at 1529nm (from 1534nm to 1529nm) after WE.

To evaluate the performance of WE II, the receiver sensitivities of the two exchanged signals are measured and compared with those of their corresponding original signals. The measured BER curves are plotted in Fig. 6. At BER of  $10^{-9}$ , the receiver sensitivities of the signals at 1534 and 1529nm are -22.4 and -23dBm, respectively. The power penalties incurred in the exchanger are measured to be 2.3 and 1.8dB, respectively. This power penalty is mainly due to the phase noise introduced by the phase dithering of the pumps, and can be improved with the complementary phase dithering approach [6].

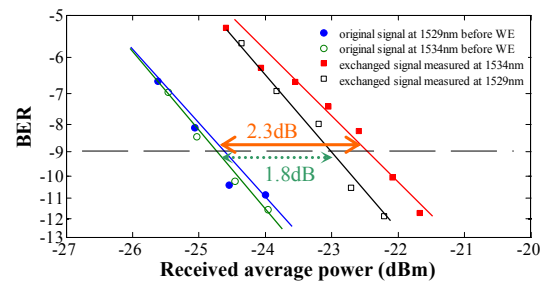

Fig. 6. Measured BER curves for the signals before and after WE.

#### IV. Conclusion

We have successfully demonstrated the performance of WE at the anomalous dispersion region. Results show that performance degradation caused by Raman gain is avoided so that a nearly-complete WE can be achieved. Extinction ratio between the converted signal and the residue is ~20dB with clear opening eyes observed. BER of  $<10^{-9}$  is achieved with power penalties of ~2dB.

#### V. Acknowledgement

The work described in this paper was partially support by a grant from the Research Grants Council of the Hong Kong Special Administrative Region, China (Project No. HKU 7179/06E).

#### VI. References

- [1] M.E. Marhic et al., *Opt. Lett.*, **21**, 1906-1908, 1996
- [2] R.W. L. Fung et al., *OECC*, paper 4D2-7, Taiwan, 2006.
- [3] R.W. L. Fung et al., *ECOC*, paper Th 1.3.2, Cannes, France, 2006.
- [4] S. K. Korotky et al., *Tech. Digest IOOC95*, paper WD2-1, Hong Kong, 1995.
- [5] K.Uesaka et al., *IEEE J. Selected Topics in Quantum Electron.*, **8**, 560-568, 2002.
- [6] K. K. Y. Wong et al., *IEEE Photon. Technol. Lett.*, **15**, 33-35, 2003.