

# A Novel Method to Design and Implement UHF Chipless RFID

Jung-Han Kim, Ki-Won Seo, Sung-Hwan Kang, Hyoung-Hwan Roh, and Jun-Seok Park

Electrical engineering department of Kookmin University, Seoul, Korea

**Abstract** - This paper introduces the RFID using the chipless tag. The proposed chipless tag provides different effective reflection ratio at each targeted frequency. This can be possible by resonator that is allocated at the center of the dipole antenna are processed by the reader RX into the binary form (zero or 1); thus, the backscatter level itself can be designated as the existence of the tag (i.e., the tag ID). The performance verification and discussion of the proposed chipless tag is presented together with experimental data.

**Key-Word** - RFID, antenna, power reflection, chipless tag, reader

## I. INTRODUCTION

Radio frequency identification (RFID) is the wireless communication which automates the enterprise supply chain management, improves the efficiency of product management. A price of the passive RFID tags has been proven to be very important feature since many mass markets need to reduce the overall costs.

A typical passive RFID system consists of two components[1]: the tag, which is located on the object to be identified, and the reader that reads/writes the data of the tags. A passive RFID tag can be composed of an antenna and chip[2]. The chip must be connected to an intermediate strap or the substrate(e.g., plastic or paper); for this electrical connection, wire bonding technique in tag manufacturing process is no small matter: the labor (e.g., package and test costs) and materials (e.g., chip failure).

If the market calls the RFID to deal with mass product that are all same type, a tag may only need to be used for tracking the product's existence. This is one of the foremost motivating reasons of using the chipless tag. RFID that uses chipless tag does not need to concern the chip problem therefore, it leads a lower cost than traditional tag. By time, many chipless tag applications have been presented [3]-[7].

This paper introduces a novel concept and prototype model of the chipless tag, as illustrated on Fig. 1. The proposed chipless tag based on the power reflection coefficient [8]. In case of a typical passive RFID tag, the reflection between the antenna and chip should be as low

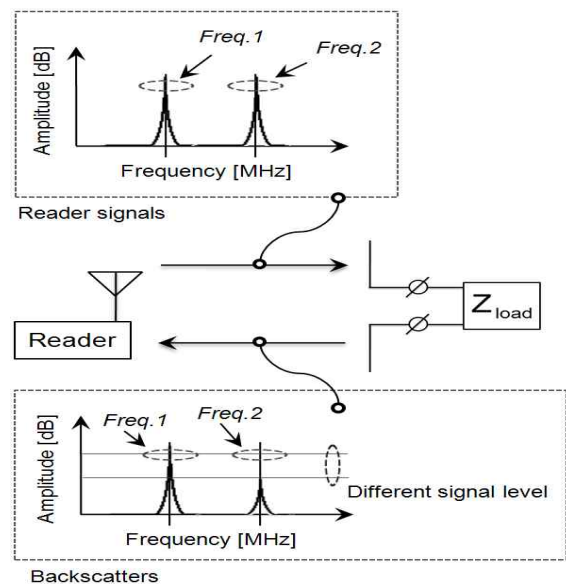

Fig 1. Concept of the proposed chipless tag and reader

as possible; however, in point of the proposed chipless tag design, the power reflection should be viewed differently: two tones of continuous wave(CW) signals are transmitted from the reader at same level, one of them should be reflected or passed by  $Z_{load}$ . One CW signal backscatters in reduced level, while another CW signal in the same level as it was. Meanwhile, in the reader receiver(RX) path, the transmitter(TX) leakage signal exists, because of the mismatch between the directional coupler and reader antenna. The two vector-summed signal, which should be TX leakage signal and

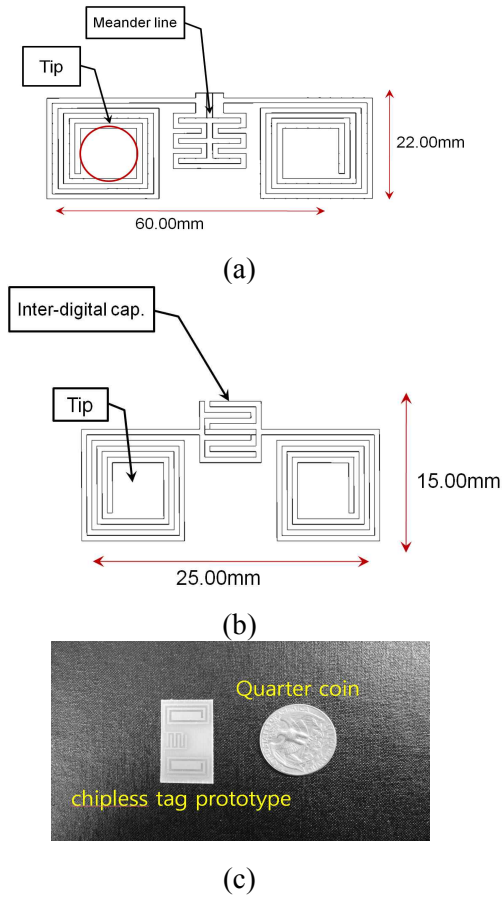

Fig 2. (a) Meander line based resonant (b) inter-digital capacitor based resonant (c) pictured prototype model

backscatters, cause the signal level difference in frequency domain (870-940MHz); hence, the reader UI design was based on the signal level between reader antenna-only case and reader antenna with chipless tag.

The paper contents are categorized as below: Section 2 details the proposed chipless tag concept, design process, and implemented prototype model. Section 3 briefly states how the reader processes the backscatters, and several key components are introduced; in addition, the advantage we can have using such a reader is discussed. Section 4 presents both chipless tag and reader prototypes, and measurement results.

## II. CHIPLESS TAG MODEL

Since one of the desired applications is that 1bit electrical article surveillance (EAS), the size is critical matter. Therefore, the proposed chipless tag design was started with understanding the merit of spiraled dipole

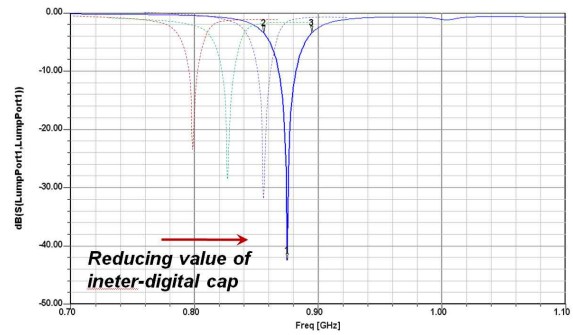

Fig 3. Simulated resonant frequency of model 2 in Fig. 2(b)

antenna. Using above-mentioned structure, it is possible to make the chipless tag to have higher antenna inductance that leads to a smaller size than a meandered dipole antenna. Note that about 15cm of effective length of antenna is related to the antenna inductance; a meandered dipole antenna that maintains this length cannot bring the competitive size or performance. Maintaining the spiraled dipole antenna form, we carried out simulation works on two cases: The first model is composed of a meandered line centered at a spiraled dipole antenna [see Fig. 2(a)]. About -40dB of minimal S11 value in the targeted band (i.e., 3-dB bandwidth), which is narrower than 100MHz. However, if we consider the case where an extremely small chipless tag is needed, this first model (total size: 22.00X60.00mm<sup>2</sup>) should be smaller. Hence, the resonator centered at the tag antenna was composed of an inter-digital capacitor form, and this is the second model [see Fig. 2(b)]. As the second model design was focused on its size, a meandered line based resonator is less effective; the use of an inter-digital capacitor enables us to minimize the overall size [see Fig. 2(c)] while a high-Q characteristic (60MHz 3-dB bandwidth) can be obtained [see Fig. 3(a)]. A small sized dipole antenna has low gain (0.4dBi); however, this was considered to be a minor problem, since the targeted interrogation range between the reader and the chipless tag is about 5cm or shorter. Another important characteristic (i.e., polarization) was simulated as well [see Fig. 3(b)].

The measurement using a network analyzer was carried out for verifying the proposed chipless tag performance [see Fig. 4(a)]. If our idea is valid, there should be the S21 level (i.e., the reader receiver input level) difference in the targeted band. As can be seen in Fig. 4(b), the above-mentioned signal level difference in frequency domain was monitored. In this measurement, the second chipless tag model was used, providing -17dB S11 centered at 880MHz (55MHz of 3-dB bandwidth). When the chipless tag model is located 3cm from the reader

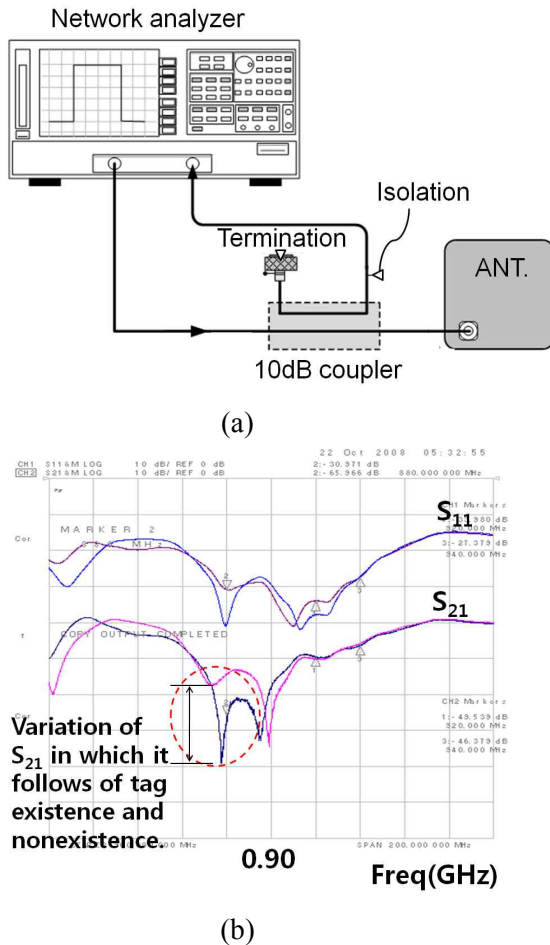

Fig 4. (a) Measurement composition using network analyzer (b) measurement results respecting two cases (with/without chipless tag)

antenna,  $S_{21}$  level was decreased from -40dB to -54dB. In our consideration, this is because signals transmitted from the network analyzer around 880MHz transfer through the termination path of the chipless tag (minimal reflection level), while the other signals are totally reflected.

Respecting the network analyzer data, the chipless tag aimed UHF RFID reader system design was carried out.

### III. CHIPLESS TAG AIMED UHF READER

Since the proposed chipless tag should be only used in 1 bit EAS, where the data transmission or case-by-case reader receiver process is not needed, the reader system

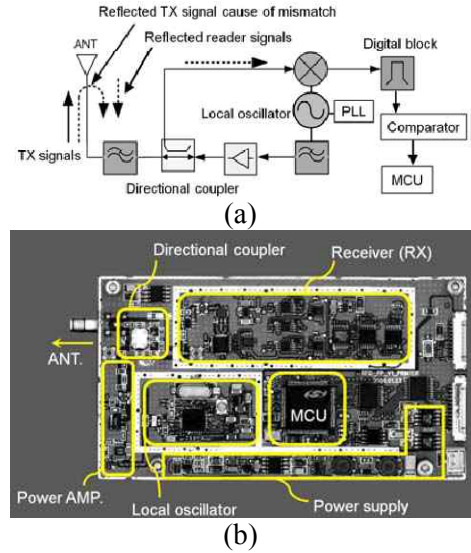

Fig 5. Entire reader block diagram (b) pictured prototype

composition was much simpler than other normal readers. The reader only transmits the two tones of CW, and the reader receiver only compares the difference of received signal level. Thus, the reader uses only down-conversion mixer to convert the received RF signal to I and Q signal [see Fig. 5(b)]. Since the TX output levels are very low, the use of band-pass filter and low noise amplifier can be optional. The reader uses the 10dB directional coupler for a single antenna, local oscillator for locking the CWs at each targeted frequency, and the micro-controller (MCU) that can be customized by user-interface software installed in host PC [see Fig. 6(a)]. The maximal transmitted power; the reader antenna gain is 6dBi.

The sequence of using the proposed chipless tag and reader is briefly explained as: the user pre-determines the targeted model is already verified using network frequency, and selects the appropriate chipless tag analyzer; then, the user setup the host PC connected with the reader so that the reader transmits the right CWs.

### IV. MEASUREMENT AND RESULTS

Before setting the user-interface software to be alarming when the chipless tag nearly approaches the reader antenna, the reference level of I and Q signals of receiver must level of I and Q signals of receiver must be clarified. Thus, many trials were carried out [see Fig. 6(a)]. This was far different from other possible conductor that may stand near by the chipless tag, and hence, this can be considered as the chipless tag's unique signal. After categorizing each chipless tag model's identity [see Fig.

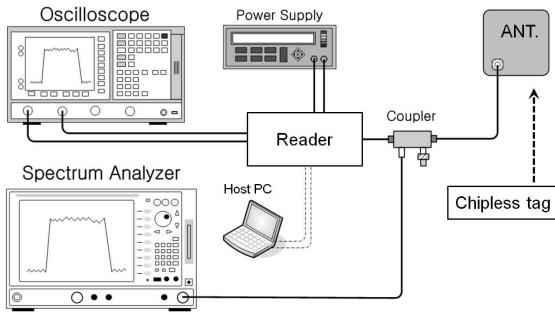

(a)

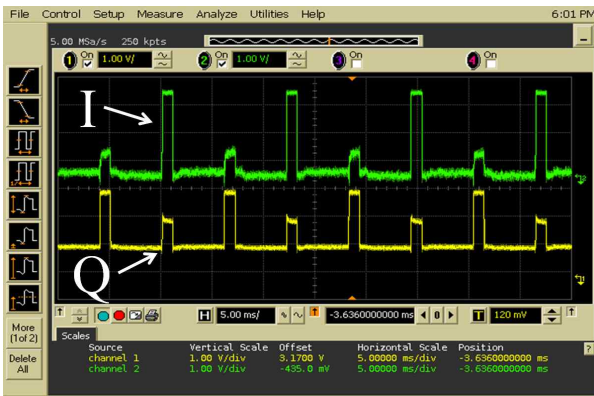

(b)

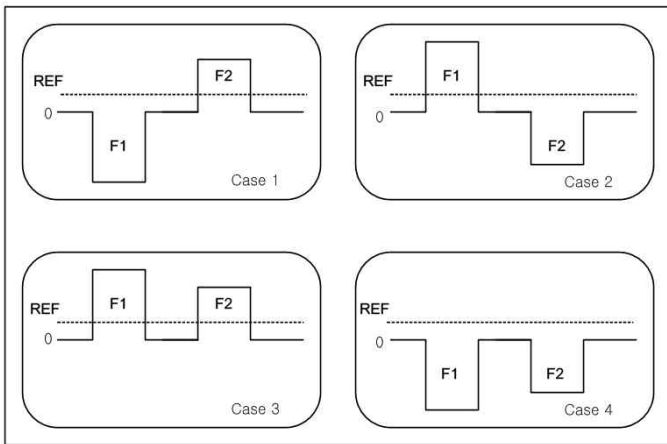

(c)

Fig 6. (a) Measurement composition (b) captured oscilloscope monitor where RX signals can be seen (c) categorized each receiver inputs from tag model

6(c)], the reference from each category was registered in host PC.

## V. CONCLUSION

The measured performance (98% readability in 5cm range) and size (15.00X25.00mm<sup>2</sup>) of proposed chipless tag was satisfactory; a prototype model is able to be used in targeted application field (i.e., tracking a large number of same products).

The future work should be concentrated on more types of the chipless tag using cheaper materials, reader minimization. Also, considering the speed of conveyor belt, collision avoidance may be the foremost challenging work

## ACKNOWLEDGMENT

This work was supported by the IT R&D program of MKE/IITA. [2008-F-050-02, Development of Self-Sustaining u-Scavenging technology for WBAN/USN]

## REFERENCES

- [1] Klaus Finkenzeller, *RFID Handbook 2<sup>nd</sup> edition*, page 7, Wiley & Sons, 2003.
- [2] K. V. S. Rao, "An overview of backscattered radio frequency identification system(RFID)", in *Asia-Pacific Microwave Conf.*, vol. 3, Nov.-Dec. 1999, pp. 746-749.
- [3] L. Reindl, G. Scholl, T. Ostertag, H. Scherr, U. Wolff, F. Schmidt, Theory and Application of Passive SAW Radio Transponders as Sensors, *IEEE Transactions on Ultrasonics, Ferroelectrics and Frequency Control*, 45(5), pp. 1281-92, ISSN 0885-3010
- [4] S., Mukherjee, "Chipless Radio Frequency Identification by Remote Measurement of Complex Impedance", *Proceedings of the 10th European Conference on Wireless Technology*, October 2007, Munich, Germany.
- [5] V. Subramanian et al, "Progress Toward Development of All-Printed RFID Tags: Materials, Processes, and Devices", *PROCEEDINGS OF THE IEEE*, VOL. 93, NO. 7, JULY 2005.
- [6] I. Jalaly, I. D. Robertson, "RF Barcodes using Multiple Frequency Bands", *Institute of Microwaves and Photonics, University of Leeds, UK*, press IEEE, 2005.
- [7] P. Berry, "The performance of New Conductive Inks for RFID smart Labels", *Smart Labels USA (IDTechEx)*, June 2005.
- [8] Nikitin et al., "Power Reflection Coefficient Analysis for Complex Impedances in RFID Design", *IEEE Transactions on Microwave Theory and Techniques*, Vol. 53, No. 9, September Techniques, Vol. 53, No. 9, September