

10B1-3

Suppression of BER fluctuations by electrical equalizer in the ultra-long 43Gb/s transmission experiments

Toshiharu Ito

System Platform Research Laboratories, NEC Corporation.

1753, Shimonumabe, Nakahara-ku, Kawasaki, 211-8666, Japan, Tel: +81-443963096, E-mail: t-ito@dl.jp.nec.com

Abstract

The use of Electrical Equalizer for PMD tolerance increase in the 43Gb/s RZ-DPSK signal transmission successfully suppresses the BER fluctuations due to time-varying PMD, which is essential for maintaining the appropriate condition of the receiver.

Introduction

In the long distance optical transmission systems using high speed channel speed of more than 40Gb/s, the signal waveform distortion due to the polarization mode dispersion (PMD) in the transmission line can be a dominant limiting factor of transmission distance.

It can be roughly said that there are two issues caused by PMD-induced signal degradation. One is that the system operation will be stopped in case when the time-varying PMD value exceeds the PMD tolerance of the receiver. The other is that the adjustment or control of receiver condition become complicated or accuracy of these processes can be spoiled. The receiver used in such high-speed transmission systems needs the precise adjustment or control of itself to cope with various degradation factors, however, only the PMD-induced degradation can be changeable with the speed faster than the ordinary control speed.

We have been experimentally investigating an EE (Electrical Equalizer) [1] applied on the 43Gb/s RZ-DPSK signal for the increase of PMD tolerance as well as the stabilization of BERs in the range of this increased PMD tolerance[2]. In these studies, we did some long-term transmission experiments using ultra long length straight transmission line in order to observe the BER fluctuations due to time-varying PMD. In this paper, we will introduce some examples of the obtained data to show how the BER fluctuations were suppressed by the EE.

Experiments

The straight transmission line used for this test had the length of 4,300km, and composed of hundred 43-km DMF spans [2]. All the experimental setup including transponder was placed in the laboratory room with stable environment. Fig.1 shows the

main part of the 43Gb/s RZ-DPSK transponder used in following evaluations. An EE, consisting of four gain stages in a four-tap transversal filter topology and a gain limiting block, was inserted at the output of the dual O/E converter.

Wavelength of the signal light from this transponder was 1550.9nm, and the input signal power into the transmission fiber was set to be -4dBm/ch.

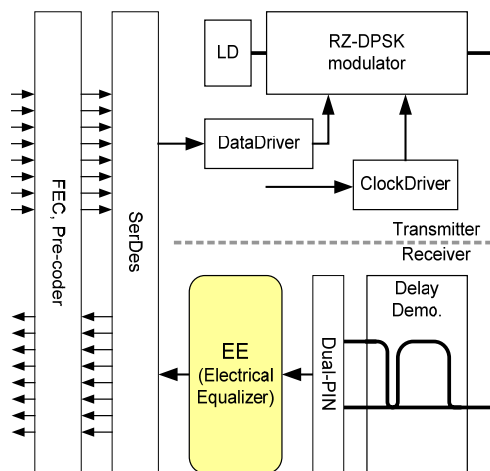

Fig.1 Transponder configuration

Table.1 List of transmission experiments

	Setting of EE	Polarization scrambling	Fluctuation of Q-factors [dB]
(a)	High sensitivity	OFF	2.31
(b)	High sensitivity	ON	1.36
(c)	Large PMD tolerance	OFF	0.88
(d)	Large PMD tolerance	ON	0.58

We have conducted long-term BER measurements for four cases, described in Table.1. The EE setting of “High sensitivity” was the setting to achieve best receiver sensitivity for non-distorted signal. With this setting, the receiving performances were nearly equal to the case without EE. A polarization scrambler was inserted at the output of transponder,

and the dependence of input polarization state into the transmission line was averaged when the scrambler was ON.

The speed of polarization scrambling was fast enough to remove the input polarization dependency in the BER averaging interval of 10 seconds. “Fluctuation of Q-factors” in Table.1 stands for the [Best Q-factor] - [Worst Q-factor] in each case. Every “Q-factor” used here was the value obtained by the calculation from BER data.

Fig.2 shows the measured Pre-FEC BER data for four cases. The measurement time was 48 hours (2 days) for each case.

Fig.2 (a) shows the measured results of case (a) where the BERs fluctuated with large vibrations (2.31dB) and with relatively short time intervals. In case (b), the fluctuations with short intervals were reduced by the adoption of polarization scrambling while the large vibrations (1.36dB) still remain.

As shown in fig.2 (c) and (d), adoption of “Large PMD tolerance” setting effectively suppressed the BER fluctuations. In case (d), “Fluctuation of Q-factors” was only 0.58dB during two days.

Discussions

The present design of the transmission systems mainly uses the average of BERs, their deviation, and the margin considering the FEC capability. The BER fluctuations which are intentionally suppressed by the EE should not be used directly in such design method since this suppressing function is effective in the finite range determined by the capability of EE. The use of some complementary techniques like in-service PMD estimation method [2] will be needed for the design with the consideration of the PMD margin.

Conclusion

We have introduced some experimental results showing how an EE affects the BER fluctuations due to the time-varying PMD in the transmission line. According to our evaluations using 4,300km straight transmission line and 43Gb/s RZ-DPSK signal, “Fluctuation of Q-factors” in continuous 48-hour measurements were improved from 2.31dB to 0.58dB. These stabilized performances will contribute to execute an accurate adjustments of the receiver conditions, and thus the further stable transmission performances will be realized.

Reference

- [1] S. Wada et.al., OFC/NFOEC 2006, paper OWE2, 2006.
- [2] T. Ito et.al., OFC/NFOEC 2007, paper NWA3, 2007.

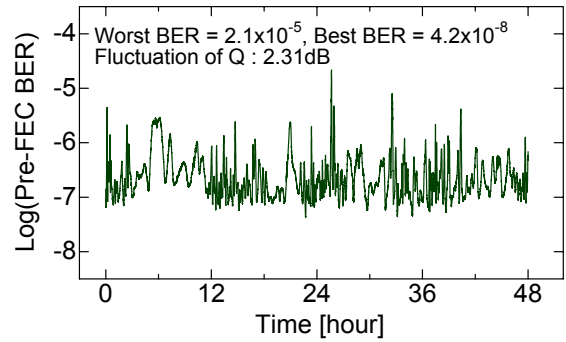

(a) EE: High sensitivity, Polarization scramble: OFF

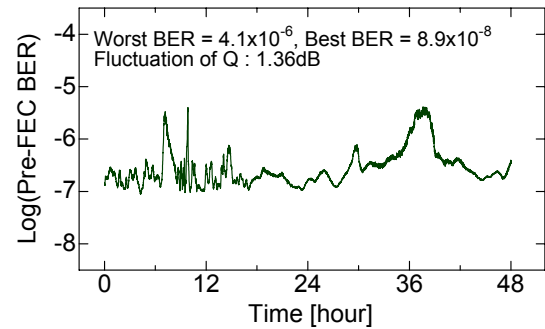

(b) EE: High sensitivity, Polarization scramble: ON

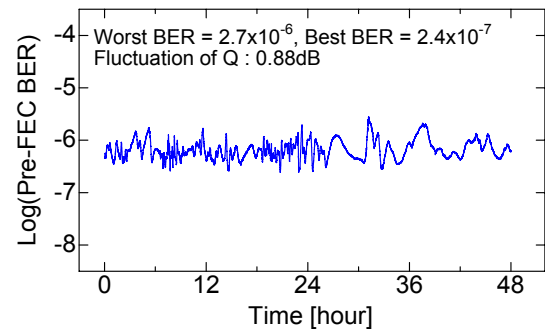

(c) EE: Large PMD tolerance, Polarization scramble: OFF

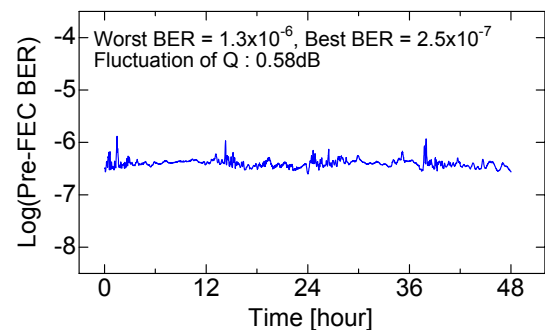

(d) EE: Large PMD tolerance, Polarization scramble: ON

Fig.2 Measured fluctuations of BERs in 48-hour experiments