



Performance Enhancement using Unitary Frequency Modulation with PLC and VLC Cooperation

Chang-Jun Ahn[†] and Yeon-Ho Chung[‡]

[†]Graduate School of Engineering, Chiba University
1-33 Yayoi-cho, Inage-ku, Chiba-shi, Chiba, 263-8522 Japan

[‡]Department of Information and Communications Engineering, Pukyong National University
599-1, Daeyon3-Dong, Nam-Gu, Busan, 608-707 Korea
Email: junny@m.icece.org

Abstract—Visible light communication (VLC) is expected as a means for ubiquitous communication using increasingly popular LED lights. However, for indoor optical channel, the received signals are with line of sight (LOS) component but also delayed components due to reflected secondary paths. Therefore, the energy is spread over the time, resulting in a reduction of the converted current at the photodiode. From this reason, the diversity gain of VLC is rarely expected as compared to radio frequency systems. To improve the VLC performance, we consider the combination of power line communication (PLC) and VLC systems for achieving the frequency diversity with unitary space-time modulation. In this paper, we propose the diagonal components of unitary signal constellation with splitting over the coherence bandwidth, and evaluate the system performance for PLC-VLC/OFDM.

1. Introduction

Using increasingly popular LED lights, the visible light communications (VLC) is expected as a means for ubiquitous communication [1]. VLC has some of the noteworthy advantages over radio frequency and infrared systems. In general, visible light does not damage to human body and eyes and VLC has high security of data because the optical signal does not pass the wall, resulting that the communication space is limited to a certain range. Moreover, since LED lighting has recently become part of a building infrastructure, making visible light communication infrastructure is fairly easy by adding communication function to LED lighting. As these features, VLC is widely considered as a new way of wireless communication technology.

However, for indoor optical channel, the received signals are with line of sight (LOS) component but also delayed components due to reflected secondary paths. Therefore, the energy is spread over the time, resulting in a reduction of the converted current at the photodiode. Furthermore, the reflected signal power is significantly reduced due to surface reflectivity. From

these reasons, the diversity gain of VLC is rarely expected as compared to radio frequency (RF) systems [2]. To improve the VLC performance, we consider the combination of power line communication (PLC) and VLC systems for achieving the frequency diversity. PLC systems have many advantages and are assumed to be one of prospective solutions for short distance or in-home communication networks [3],[4]. PLC takes the advantage of use in everywhere at home without additional network line. VLC is easily implemented by using PLC system. However, power line channel is the time-and-frequency variant and exhibits remarkable difference between locations, according to its network topology, the types of wire lines. Moreover, many electrical appliances frequently cause man-made electromagnetic noise on power line channels. Due to the above-mentioned PLC properties, the performance of PLC system would be degraded. However, using time-and-frequency variance of PLC channel, the diversity gain is also expected. To overcome the above-mentioned problems and improve the system performance of PLC-VLC/OFDM, in this paper, we consider the unitary signal constellation scheme [5],[6].

2. System model

2.1. Indoor Optical Wireless Channel

An electrical current $y(t)$ at the receiver due to the transmitted optical intensity waveform $x_v(t)$ can be expressed as

$$y(t) = r\zeta h_v(t)x_v(t) + w(t), \quad (1)$$

where r is the responsivity of the photodiode at the receiver, ζ is the effective receiver area, $h_v(t)$ is the optical channel impulse response, and $w(t)$ is the noise component. For the free-space indoor optical channel, the received signals are with LOS component but also delayed components due to reflected secondary paths. Therefore, the energy is spread over the time, resulting in a reduction of the converted current at the photodiode. Furthermore, the reflected signal power is significantly reduced due to surface reflectivity. From these

reasons, the diversity gain is rarely expected as compared to RF systems. Therefore, the combination of PLC and VLC is considerable approach for achieving the diversity gain.

2.2. PLC Channel Model

Power line channel is the time-and-frequency variant and exhibits remarkable difference between locations, according to its network topology, the types of wire lines. Moreover, many electrical appliances frequently cause man-made electromagnetic noise on power line channels. Such man-made noise has the impulsive characteristics. Here, we introduce Middleton's class A noise model [7] into a statistical model of impulsive noise environment. Middleton's noise model is composed of sum of Gaussian noise and impulsive noise. According to the class A noise model, the PDF (Probability Density Function) of the noise amplitude ς is as follows,

$$p_a(\varsigma) = \sum_{m=0}^{\infty} \frac{e^{-A} A^m}{m!} \frac{1}{\sqrt{2\pi\sigma_m^2}} \exp\left(-\frac{\varsigma^2}{2\sigma_m^2}\right), \quad (2)$$

where $\sigma_m^2 = \sigma^2 \frac{(m/A) + \Gamma}{1 + \Gamma}$, A is the impulsive index, $\Gamma = \sigma_G^2 / \sigma_I^2$ is the GIR (Gaussian-to-impulsive noise power ratio) with Gaussian noise power σ_G^2 and impulsive noise power σ_I^2 , and $\sigma^2 = \sigma_G^2 + \sigma_I^2$ is the total noise power. The noise amplitude ς followed by Eq.(2) always includes the background Gaussian noise with power σ_G^2 . On the other hand, sources of impulsive noise are distributed with Poisson distribution ($e^{-A} A^m / m!$). One impulsive noise source generates noise which is characterized by the Gaussian PDF with variance σ_I^2 / A . The parameter A is defined as the average number of impulses on the receiver in unit duration times the mean duration of them. As the Gaussian noise power σ_G^2 is comparatively larger in the total noise power σ^2 , that is, Γ is larger, the class A noise will approach to the Gaussian noise. Conversely, the smaller Γ , the class A noise will be more impulsive.

2.3. A Class of Unitary Space-Time Signal Constellations

Unitary space-time signal is a matrix, whose rows are transmitted from the transmitted elements and mutually orthogonal to each other in wireless communication systems. Let $C \geq 2$ denotes the size of a unitary signal constellation. We define $\theta_C = \frac{2\pi}{C}$. For any given integers $\eta_1, \eta_2, \eta_3 \in Z$, we define the following unitary signal constellation of size C

$$\nu = \nu(\eta_1, \eta_2, \eta_3) = \{\xi(c\eta_1, c\eta_2, c\eta_3) \mid c \in Z_C\}, \quad (3)$$

where $Z_C = (0, 1, \dots, C - 1)$, and, $\xi(c\eta_1, c\eta_2, c\eta_3)$ is given by

$$\begin{aligned} \xi(c\eta_1, c\eta_2, c\eta_3) &= \begin{pmatrix} e^{j\eta_1\theta_C} & 0 \\ 0 & e^{j\eta_1\theta_C} \end{pmatrix}^c \\ &\cdot \begin{pmatrix} \cos(\eta_2\theta_C) & \sin(\eta_2\theta_C) \\ -\sin(\eta_2\theta_C) & \cos(\eta_2\theta_C) \end{pmatrix}^c \\ &\cdot \begin{pmatrix} e^{j\eta_3\theta_C} & 0 \\ 0 & e^{-j\eta_3\theta_C} \end{pmatrix}^c. \end{aligned} \quad (4)$$

For any given constellation size $C \geq 2$, we will find a unitary signal constellation from the following class

$$\Omega_C \equiv \{\nu(\eta_1, \eta_2, \eta_3) \mid \eta_1, \eta_2, \eta_3 \in Z_C\}, \quad (5)$$

such that the unitary signal constellation has the largest diversity product in the constellation class as Eq. (5). The above unitary signal constellation is built from the parametric form of 2×2 unitary matrices. The signal constellation as Eq. (4) is called *parametric code*. It is seen that when $\eta_2 = \eta_3 = 0$ is imposed in the constellation class as Eq. (5), the parametric code as Eq. (4) is exactly the *diagonal code* in the case $M = 2$ where M is the number of diagonal element. There have been several classes of 2×2 unitary space-time constellation which were proposed in the previously [6]. A diagonal code cyclic group code for a general M was introduced. A main difference between the diagonal code and the parametric code is that the diagonal code is in general a non-group signal constellation.

3. PLC-VLC/UFM-OFDM

Here, we employ the diagonal code for achieving a diversity gain in the PLC channel. The data stream is divided into bit sequences that consist of $R \cdot M$ bits, where R and M denote information bits per parallel symbol to be transmitted, and the number of diagonal element. Each $R \cdot M$ bit sequence is mapped into the constellation $\nu(c)$ ($c \in Z_C$) selected from $C = 2^{RM}$. The constellation of unitary matrix can be written as

$$\text{diag}\{\nu(c)\} = [e^{jc\theta_C}, \dots, e^{jc\theta_C}], \quad (c \in Z_C) \quad (6)$$

where $\nu(c)$ is $M \times M$ unitary matrix, $\text{diag}\{\cdot\}$ is the diagonal operator, respectively. For example, in the case of $M = 2$ and $R = 1$, which is equal to BPSK modulation. In this case, one of 2×2 unitary matrix $\nu(c)$ is assigned.

In a PLC channel, we assume that a propagation channel consists of L discrete paths with different time delays due to the power line. The impulse response $h_p(\tau, t)$ is represented as

$$h_p(\tau, t) = \sum_{l=0}^{L-1} h_l(t) \delta(\tau - \tau_l), \quad (7)$$

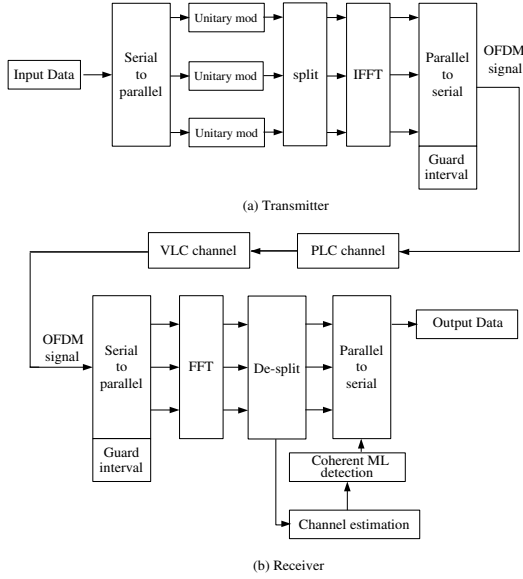

Figure 1: Proposed PLC-VLC/UFM-OFDM system.

where h_l and τ_l are the PLC complex channel gain and the time delay of the l th propagation path, respectively. Through the VLC channel, the channel transfer function $H(f, t)$ is the Fourier transform of $r\zeta h_v(t)h_p(\tau, t)$ and is given by

$$\begin{aligned} H(f, t) &= \int_0^\infty r\zeta h_v(t)h_p(\tau, t) \exp(-j2\pi f\tau) d\tau \\ &= r\zeta \sum_{l=0}^{L-1} h_v(t)h_l(t) \exp(-j2\pi f\tau_l). \end{aligned} \quad (8)$$

Observing Eq. (8), we split the diagonal components over the coherence bandwidth, the detected signal can achieve the frequency diversity. In this paper, we employ the diagonal code and split diagonal components of the selected code over the coherence bandwidth. Hereafter, we call this processing as an unitary frequency modulation for PLC-VLC/OFDM (PLC-VLC/UFM-OFDM). In the PLC-VLC/UFM-OFDM systems, the diagonal components of the selected unitary signal constellation are splitting over the coherence bandwidth and are transmitted to the receiver via PLC and VLC channels. In this case, the received signal $Y(k)$ of the k -th subcarrier at receiver side is given by

$$Y(k) = H(k)X(k) + N(k) \quad k = 1, \dots, K, \quad (9)$$

where $X(k)$ is the split diagonal component of unitary signal constellation over the coherence bandwidth, and N is the impulsive noise and additive white Gaussian noise. After de-splitting of the received signals and channel estimation, the frequency domain signals Y are divided into M bits. Here, we consider the same

structure of unitary signal constellation for $M \times M$ as Eq. (6). Each M bit of frequency domain signals is demodulated by ML estimator. The ML decision rule of the signal model as Eq. (8) is given by

$$\hat{\nu} = \arg \min \sum_{k=1}^K \left| Y(k) - H(k) \right. \\ \left. \cdot \sum_{c=1}^C \text{diag}(\nu)_{\text{mod}(k, M)+1}(c) \right|^2, \quad (10)$$

where $\sum_{c=1}^C \text{diag}(\nu)_{\text{mod}(k, M)+1}(c)$ is the diagonal component of unitary signal constellation. The neighboring signals of $\sum_{c=1}^C \text{diag}(\nu)_{\text{mod}(k, M)+1}(c)$ without splitting must have correlated channel responses, however, the split signals over the coherence bandwidth achieve totally different channel responses. It means that PLC-VLC/UFM-OFDM systems can achieve a frequency diversity gain.

4. Computer simulated results

In this section, the system performance of the proposed PLC-VLC/UFM-OFDM system is compared with the conventional VLC/OFDM. Fig. 1 shows the simulation model of UFM-PLC/OFDM for $N_c = 128$ subcarriers over the impulsive noise and multipath PLC & VLC channels. In the transmitter, data stream is serial-to-parallel(S/P) transformed, and the diagonal components of unitary signal constellation are split over the coherence bandwidth. The simulation parameters are listed in Table 1.

Fig. 2 shows the BER performance of PLC/OFDM and PLC/UFM-OFDM with splitting size of 16 and 64 ($A=0.001$, $\Gamma=0.001$). For BER of 2×10^{-3} , the PLC/UFM-OFDM with splitting size of 16 and 64 performs better than PLC/OFDM by 4dB and 7dB. This is because PLC/UFM-OFDM can achieve a diversity with splitting the diagonal components over the coherence bandwidth for a frequency diversity.

Fig. 3 shows the BER performance of PLC/OFDM and PLC/UFM-OFDM with splitting size of 16

Table 1: Simulation parameters.

Data Modulation	BPSK
Demodulation	ML detection
Data rate	4 Msymbol/s
OFDM Symbol duration	65 μsec
Number of carriers	128
Channel	2 path quasi-static
Maximum path delay	0.5 μsec (PLC) 0.3 μsec (VLC)
Noise model	Middleton's class A $A=(0.001, 0.01)$, $\Gamma=(0.001, 0.01)$

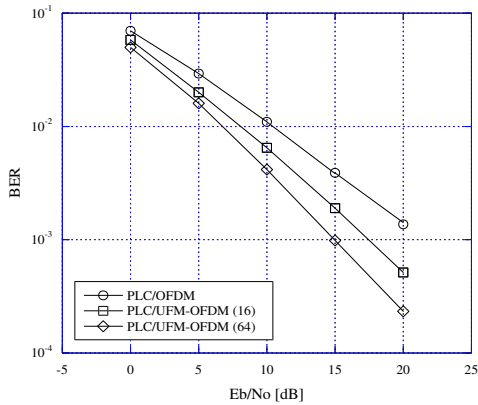

Figure 2: BER performance for $A=0.001$, $\Gamma=0.001$.

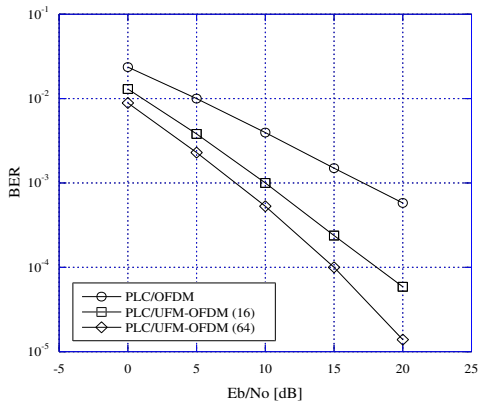

Figure 3: BER performance for $A=0.01$, $\Gamma=0.01$.

and 64 ($A=0.01$, $\Gamma=0.01$). PLC/UFM-OFDM and PLC/OFDM with weak noise achieve better BER performance than those of with strong noise.

Fig. 4 shows the BER performance of VLC/OFDM, PLC-VLC/OFDM and PLC/UFM-OFDM with heavy ($A=0.001$, $\Gamma=0.001$) and weak ($A=0.01$, $\Gamma=0.01$) noises. From the simulation result, VLC/OFDM and PLC-VLC/OFDM show the approximately same BER performance under the heavy and weak noises. On the other hand, VLC-PLC/UFM-OFDM with splitting size of 64 shows the superior BER performance for heavily and weakly distributed impulse noise channel. This is because PLC/UFM-OFDM can achieve a diversity with splitting the diagonal components over the coherence bandwidth for a frequency diversity in the PLC channel.

5. Conclusion

We have investigated the performance improvement of PLC-VLC/UFM-OFDM over the multipath and impulsive noised PLC and VLC channels, and eval-

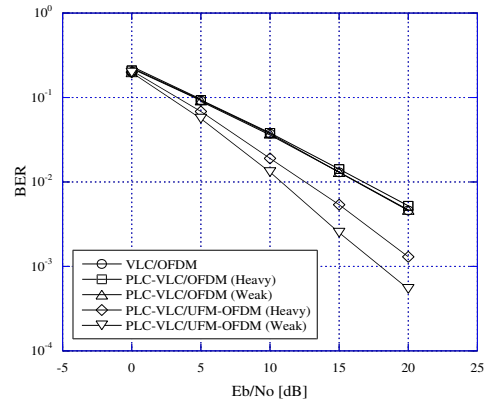

Figure 4: BER performance of VLC/OFDM, PLC-VLC/OFDM and PLC/UFM-OFDM with heavy and weak noises.

uated the BER performance. The proposed PLC-VLC/UFM-OFDM system can achieve 5 and 4dB gains compared with VLC/OFDM for BER of 10^{-2} under the heavy and weak noises, respectively.

References

- [1] M. Kavehradwa, "Sustainable energy-efficient wireless applications using light," *IEEE Communications Magazine*, December 2010.
- [2] M. Biagi, and A. M. Vegni, "Enabling high data rate VLC vis MIMO-LEDs PPM," *Proc. of Globecom 2013*, pp.1058-1063, 2013.
- [3] M. Crussier, J. Baudais, and J. Helard, "Rebust and high bit rate communications over PLC channel: a bit loading multi-carrier spread spectrum solution," *Proc. of ISPLC2005*, pp.37-41, 2005.
- [4] C. L. Giovanelli, B. Honary, and P. Farrell, "Space-frequency coded OFDM system for multi-wire power line communications," *Proc. of ISPLC2005*, pp.191-195, 2005.
- [5] T.L.Marzetta, and B.M. Hochwald, "Capacity of a mobile multiple-antenna communication link in Rayleigh flat fading," *IEEE Trans. on Information Theory*, vol.45, no.1, pp.139-157, Jan., 1999.
- [6] B.M. Hochwald, and T.L.Marzetta, "Unitary space-time modulation for multi-antenna communications in Rayleigh flat fading," *IEEE Trans. on Information Theory*, vol.46, no.2, pp.543-563, Mar., 2000.
- [7] D. Middleton, "Stastical-physical model of electromagnetic interference," *IEEE Trans. on Electromagn. Compat.*, vol.19, no.3, pp.106-126, August, 1977.