

# Characteristics of the Radiated Emission from a Multilayer PCB with a Slit

Kenichi NAKAYAMA , Kenichi KAGOSHIMA , and Shigeki OBOTE

Department of Media and Telecommunications Engineering ,  
Faculty of Engineering , Ibaraki University  
4-12-1 Nakanarusawa , Hitachi , Ibaraki , 316-8511 Japan  
E-mail:nm1666n@hcs.ipc.ibaraki.ac.jp

## 1. Introduction

EMC regulations for the electronics devices such as handheld phones , personal digital assistants and so on have become strict in the view points of engineering and economics . One of the technical problems is to clear how the radiated emission occurs from the electronics devices , and interfere to the surrounding devices . The legal instruction about medical apparatus has been published in June 1993 to protect the medical instruments from electronics digital devices[1] .

In digital devices , printed circuit boards(PCB's) are commonly used and are supposed to be non-radiating devices .In fact ,the PCB's radiate electromagnetic energy to the space and interfere the devices located at the surroundings(Fig . 1) .

In the multilayer PCB since a power layer and a ground layer act as parallel resonator strong radiated emission occurs at this resonance frequencies[2] . When there is a slit on the power layer , resonant frequencies of the parallel layers change from those of the original configuration without a slit and these are confirmed by experiments and numerical analysis . However , the level of the radiated emission at each resonant frequency which is more important to evaluate EMC between electronic devices has not been reported[3] , [4] . In this paper , we investigate the level of the radiated emission quantitatively using measurements and numerical analyses . And the design guide lines for the multilayer PCB with a slit will be discussed .

## 2. Analysis and Measurement of The PCB

Figure 2 shows the PCB used for the analysis and measurement . The size of the board is 240mm  $\times$  170mm with a thickness of 1.6mm . The slit is located at the center of the power layer parallel to Y-axis . The measurement was conducted in a radio anechoic chamber . The PCB was placed normal to the vector between the PCB and the receiving antenna , and the radiated emission normal to the PCB was measured . The RF power was supplied via a coaxial cable with characteristic impedance of 50  $\Omega$  and the supplied voltage was 100mV . Frequency range of measurement was from 30MHz and 800MHz . The distance between the antenna and the PCB is 3m . FD-TD method was used to analyze the electromagnetic characteristics of the PCB . The area of the analysis was 1400  $\times$  1400  $\times$  1200  $mm^3$  including the absorbing boundary . As an absorbing boundary condition , PML with five layer was adopted .

### 3. Results

#### 3.1 Frequency Characteristics of the Measured Radiated Emission

The measurement results of the electric field strength are shown in Fig . 3 . Fig . 3(a) is the field strength of the horizontal polarization and Fig . 3(b) is of the vertical polarization .The length of the slit was varied at 0mm ,80mm and 160mm .In the horizontal polarization ,the resonant frequency of fundamental mode of the PCB without slit is 301MHz ,being shifted to low frequency by the slit . The lowest resonant frequency of the PCB with a slit length of 80mm was 240MHz , although the radiated emission fell by about 10dB compared to the PCB without a slit . When the length of the slit was 160mm , resonant frequency has become much lower to 130MHz and the radiated emission reduced by about 16dB compared to the PCB without a slit . On the other hand , the resonant frequencies in the vertical polarization hardly changed the radiated emission didn't change either . The reason why resonant frequencies changed in the horizontal plane and didn't in the vertical plane was well explained using the calculated current distribution on the PCB[6] . However , the reason why the radiated emission of the PCB with a slit was decreased has not been cleared yet and we analyze the radiation pattern of the PCB in the next section .

#### 3.2 Far-Field Pattern of the PCB

Figure 4 shows the calculated far-field pattern of the PCB with and without a slit at a lowest resonant frequency .Fig . 4(a) shows the far-field pattern of the PCB without a slit at the frequency of 301MHz . Maximum radiation occurs to the Z-direction which correspond to the horizontal polarization of the  $TM_{10}$  mode peak in Fig . 2(a) . Fig . 4(b) shows the calculated far-field pattern of the PCB with a slit length of 160mm at the frequency of 130MHz . The radiation of the  $E_f$  component in the Y-Z plane correspond to the radiation in horizontal plane of Fig . 2(a) .It is clear that the radiation of the PCB with a slit to the Z-axis in the horizontal polarization much decreased compared to the that of the PCB without a slit . To investigate the reason why the radiation emission was decreased in the case of the PCB with a slit , we analyzed the near field of the PCB with and without a slit and show the results in Fig . 5(a) and Fig . 5(b) , respectively . It is understood that the near fields of the PCB with a slit differ in the directions to  $\pm Z$  each other and that the field in the slit side is decreased . However , more calculation and measurements will be required to clear the reason qualitatively why the radiated emission of the PCB with a slit decreases compared to that of the PCB without a slit .

### 4. Conclusion

We evaluated radiated emissions quantitatively from a multilayer PCB with a slit . The following conclusions were obtained from the measurement and the analysis result .

- (1) When a slit exists , it may disturb of the current distribution on the PCB , radiated emission at the lowest resonant frequency decreases , as well as the value of the resonant frequency in the horizontal polarization .
- (2)It is found that the radiated emission becomes maximum to the normal of the PCB at least at the lowest frequency , however more investigations will be required at higher mode resonant frequencies .

### 5 . Reference

- [1]T . MIYASHITA , et al , " Medical Facilities Electromagnetic Interference " July 2000
- [2]T . HARADA , H . SASAKI , and T . KURIYAMA , " Characteristic of Radiated Emission form Traces

- Placed between Power and Ground Planes ,” IEICE Technical Report , EMCJ2001-38 , July 2001
- [3]K .ERIKAWA , and Y . KAMI , “ On a Resonance Between Power-Supply and Ground Planes Having Lack Partially ” IEICE Technical Report , EMCJ 98-7 , April 1998
- [4]N . OKA , Y . SASAKI , “ Experimental Evaluation of Isolation Effect on a PCB with divided Planes , ” Proceeding of The 2001 Communications Society Conference of IEICE , B-4-43 , Sep . 2001
- [5]K . NAKAYAMA , K . KAGOSHIMA , and S . OBOTE , “ The FDTD Analysis of the Resonant phenomenon Between Power Plane and Ground Plane in Multilayer PCB , ” IEICE Technical Report , A · P2001-38 , July 2001

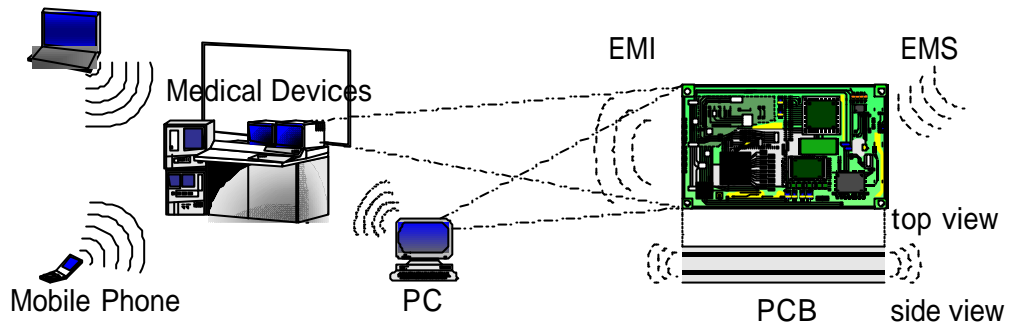

Fig.1 Radiation Emission from PCB in medical equipment.

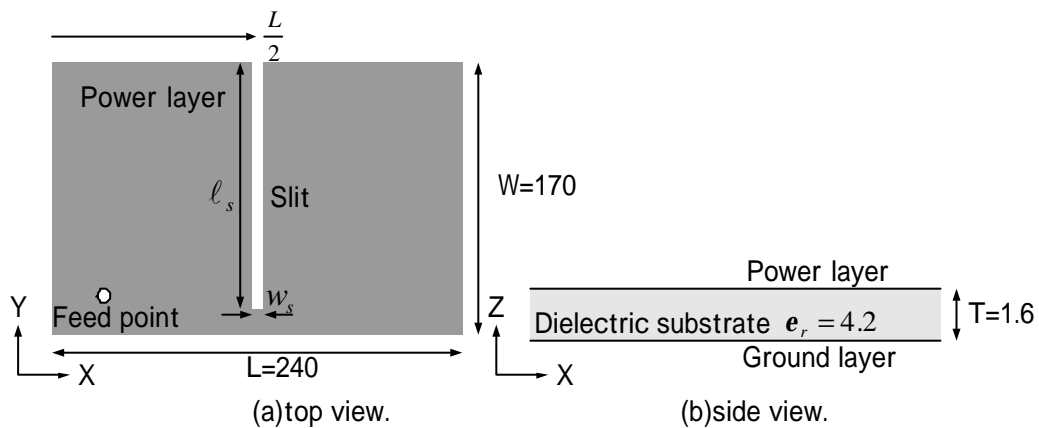

Fig.2 Structure of the PCB with a slit (unit: mm).

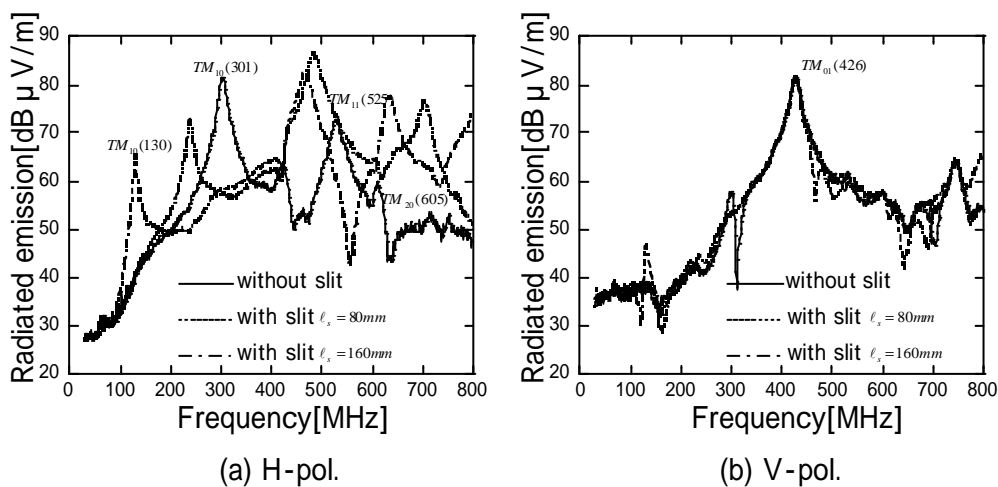

Fig.3 The measured radiation from the model.

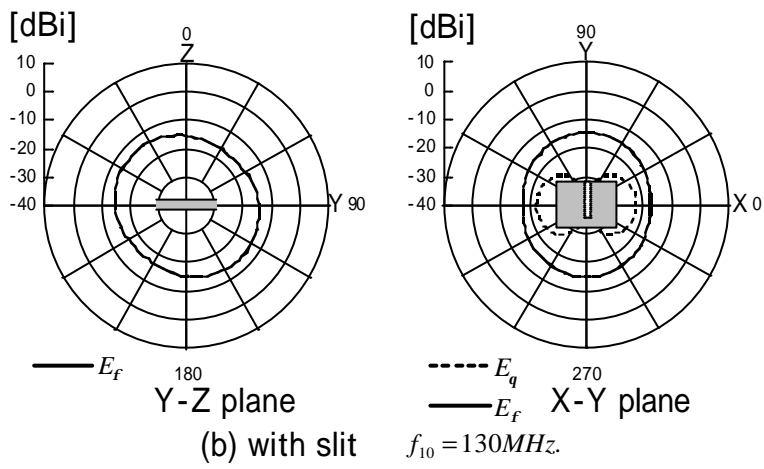
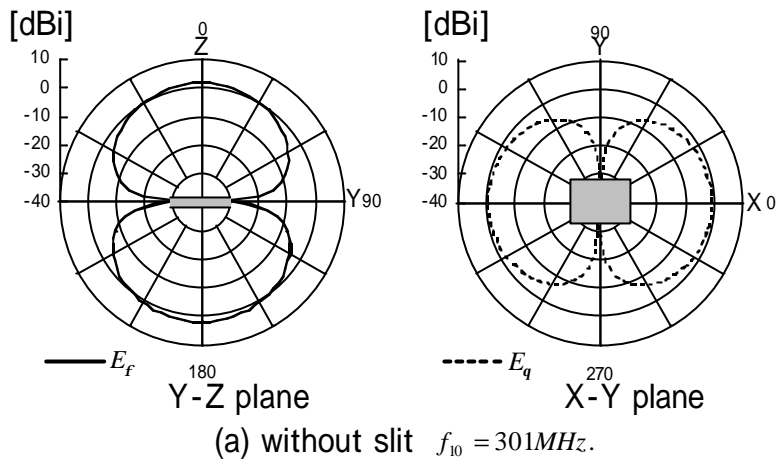

Fig.4 Radiation patterns.

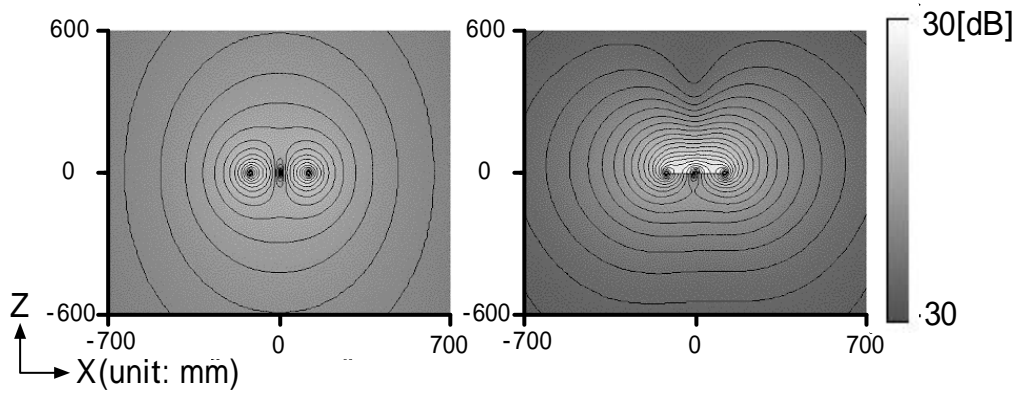

Fig.5 X-Z plane of near electric field distribution.