

# MMSE Adaptive Array Antenna with Dual-Mode Space-Temporal Simultaneous Processing Equalizer

Yoshihiro ICHIKAWA, Shigeki OBOTE, and Kenichi KAGOSHIMA

Department of Media and Telecommunications Engineering,  
Faculty of Engineering, Ibaraki University  
4-12-1 Nakanarusawa, Hitachi, Ibaraki, 316-8511 Japan  
E-mail:nd1301g@hcs.ipc.ibaraki.ac.jp

## 1. Introduction

An adaptive array antenna(AAA) is very effective to achieve low bit error rate(BER) in mobile communication environments. However, it is difficult for the AAA to converge in multipath fading situation. In multipath propagation environment, space-temporal equalizers seem to be effective. Therefore, we have proposed the space-temporal simultaneous processing equalizer (ST-SPE) that is sequentially connected of an AAA and a linear equalizer (LE) [1]. The ST-SPE is simple and effective in multipath propagation environment, and can reduce the computational complexity in comparison to the tapped-delay-line adaptive array antenna (TDL-AAA). The ST-SPE works effectively under the minimum phase condition such as appeared at line-of-sight (LOS) propagation environment. However, the ST-SPE cannot work in the non-minimum phase condition which usually arises at non-line-of-sight (NLOS) propagation environment. On the other hand, the TDL-AAA that is synchronized at the center tap(TDL-AAA<sub>CEN.</sub>) can work in the non-minimum phase condition, although the TDL-AAA requires more the number tap stages of  $2P_{\text{TDL}} + 1$  ( $P_{\text{TDL}}$ :the required number of tap stages for equalization).

In this paper, we propose a space-temporal simultaneous processing equalizer which is simple configuration and works in non-minimum phase condition, too. The proposed method is the dual-mode space-temporal simultaneous processing equalizer(Dual-mode ST-SPE) which equalizes the signal in a frame both forward and backward[2]. First, we describe the problem of a conventional ST-SPE in the non-minimum phase condition in Sec.2. Next, we propose the Dual-mode ST-SPE in Sec.3. In Sec.4, we show numerical results of the Dual-mode ST-SPE by computer simulations and investigate the required total number of taps and the number of tap stages in the Dual-mode ST-SPE and the TDL-AAA<sub>CEN</sub> in order to achieve the same MMSE. We also discuss computational complexities of the Dual-mode ST-SPE and the TDL-AAA in Sec.5.

## 2. Problem of the ST-SPE in Non-Minimum Phase Condition

Figure 1 shows the configurations of the ST-SPE and the TDL-AAA[4]. In Fig.1,  $M$  is the number of elements and  $P_{\text{LE}}$  is a number of tap stages. The ST-SPE consists of an AAA and a linear equalizer(LE) with the first tap weight fixed. The TDL-AAA has a tapped delay line (TDL) in each antenna element. The required number of tap stages of the ST-SPE for equalization is almost the same as that of the TDL-AAA to achieve the same mean square error(MSE) under minimum phase condition[3]. However, the ST-SPE cannot work in the non-minimum phase conditions. Figure 2 shows the MSE of the ST-SPE and the TDL-AAA, which are synchronized at the first tap. Simulation condition is shown in Table 1, where  $z^{-1}$  means the delay of a symbol period. It is assumed that one delayed wave exists close to a direct wave. Symbol synchronization and frame timing are assumed to be ideal. We assumed two propagation conditions. One is minimum phase condition (min:  $a=1.0, b=0.7$ ) and the other is non-minimum phase condition

(non-min:  $a = 0.7, b = 1.0$ ). In Fig.2, both ST-SPE and the TDL-AAA that is synchronized at the first tap cannot achieve low value of MSE under the non-minimum phase condition even increasing the number of tap stages

### 3. Dual-mode ST-SPE

Figure 3 shows the proposed Dual-mode ST-SPE and the frame structure. The conventional ST-SPE equalizes the signal in a frame forward only. However, after A/D conversion, the Dual-mode ST-SPE accumulates the signal of a frame in the buffer memory. First, the signal in a frame is equalized forward. When the MSE becomes larger than the threshold level, the Dual-mode ST-SPE equalizes the signal backward. After the comparison of these MSE, the output signal of the smaller MSE is selected. On the other hand, when we have two signal processors, we can equalize the signal both forward and backward simultaneously.

The required total number of taps for both forward and backward is  $2 \times (M + P_{LE} - 1)$  taps and is about twice taps of the conventional ST-SPE. However, the TDL-AAA<sub>CEN</sub>, which works in non-minimum phase condition, needs  $M \times (2P_{TDL} + 1)$  taps. We show that quantitative analysis of these two values that are very different in Sec.4.

## 4. Performance Evaluation

### 4.1 Convergence Characteristic

Figure 4 shows the convergence characteristic of the Dual-mode ST-SPE in multipath environment. The simulation condition is shown in Table1. We compare the Dual-mode ST-SPE with TDL-AAA<sub>CEN</sub>. Dual-mode ST-SPE has the same performance as the TDL-AAA<sub>CEN</sub> in non-minimum phase condition.

### 4.2 Required Total Number of Taps for Equalization

We investigated the required total number of taps and the number of tap stages in order to achieve the same MSE. Figure 5 and Figure 6 show the MMSE, which is the average of 500 samples after convergence. In Fig.5, the Dual-mode ST-SPE in non-minimum phase condition has almost the same performance as the conventional ST-SPE in minimum phase condition. The MSE of the Dual-mode ST-SPE and the conventional ST-SPE reaches the same MMSE at around 11 taps, respectively. In this case, since antenna elements are four, the number of tap stages is eight.

Figure 6 shows the MSE of the TDL-AAA<sub>CEN</sub>. In this case, the MSE reaches the same MMSE as that of the Dual-mode ST-SPE at around 68 taps, respectively. The number of tap stages ( $P_{TDL}$ ) is also eight.

## 5. Computational Complexity

In Fig.7, we compare the number of multiplications of the Dual-mode ST-SPE with the TDL-AAA<sub>CEN</sub> using RLS algorithm[5]. The Dual-mode ST-SPE needs  $2(M + P_{LE} - 1)$  taps for computation while the TDL-AAA<sub>CEN</sub> needs  $M(2P_{TDL} + 1)$  taps. The horizontal axis shows total number of taps. Since  $P_{TDL}$  and  $P_{LE}$  are eight and antenna elements are four, the multiplication of the Dual-mode ST-SPE is 462 in an iteration, while the TDL-AAA<sub>CEN</sub> needs 7242. The computation load is reduced to 1/16.

## 6. Conclusion

We proposed the Dual-mode ST-SPE, which works effectively in both minimum phase condition and non-minimum phase condition. We confirmed the convergence characteristics of the Dual-mode ST-SPE in the non-minimum phase condition. It has been found that the number of tap stages of the Dual-mode ST-SPE in non-minimum

phase condition is the same as that of the ST-SPE in minimum phase condition. To achieve the same MSE, the required number of tap stages of the ST-SPE is almost the same as that of the TDL-AAA.

The Dual-mode ST-SPE can reduce the computational complexity compared to the TDL-AAA<sub>CEN</sub>. The computation load of the Dual-mode ST-SPE is reduced to 1/16, when  $P_{TDL}$  and  $P_{LE}$  are eight and antenna elements are four.

## Reference

- [1] Y.Ichikawa, K.Tomitsuka, S.Obote, and K.Kagoshima, "Computational Complexity Reduced MMSE Adaptive Array Antenna with Space-Temporal Joint Equalization," (APCC 2001 Proceedings) IEICE. COMMUN., vol.E84-B, no.11 Appendix pp280-284, Nov. 2001.
- [2] A.Higashi, H.Suzuki, "Dual-mode equalization for digital mobile radio," IEICE B- vol.J74-B- No.3 pp.91-100 March 1991.
- [3] Y.Ichikawa, K.Tomitsuka, S.Obote, and K.Kagoshima, "A Computational Complexity Reduced MMSE Adaptive Array Antenna with Space-Temporal Joint Equalization," IEICE. COMMUN., March 2002. To be submitted.
- [4] N. Ishii, and R. Khono, "Spatial and temporal equalization based on an adaptive tapped-delay-line array antenna," IEICE Trans. Commun, vol.E78-B, no.8, pp.1162-1169, Aug. 1995.
- [5] Simon Haykin, "Introduction to Adaptive Filters," Macmillan publishing Company, 1984.

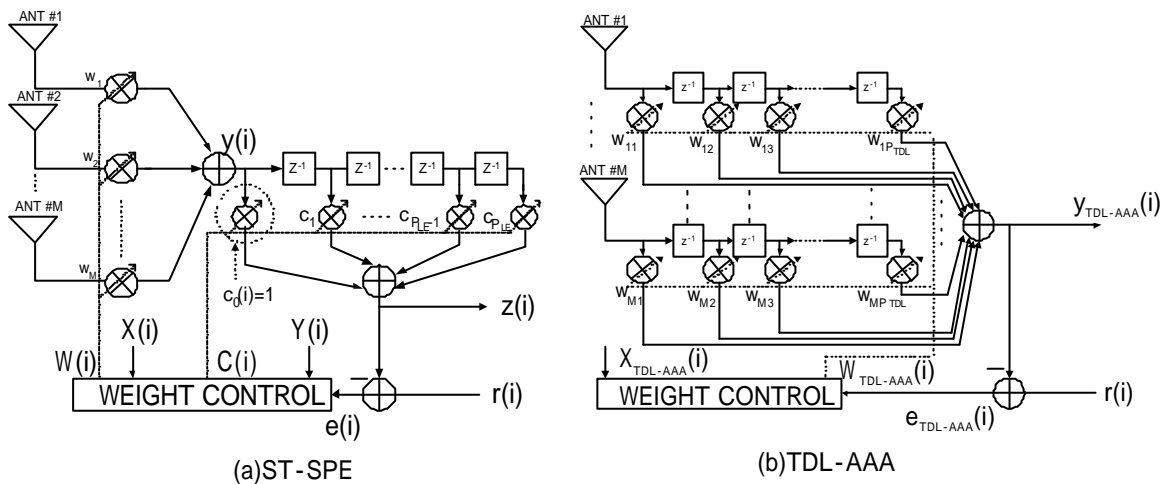

Fig.1 Conventional method.

Table 1 Simulation condition.

Elements (M)	4 elements, Circular
Elements space	$\lambda / 2$
Algorithm	RLS ( $g = 0.999$ )
Tap stage	8 taps ( $P_{TDL}, P_{LE}$ )
Desired wave	$a(0[\text{deg}]) + bz^{-1}(2[\text{deg}])$
Interference wave	1: $a(40[\text{deg}]) + bz^{-1}(42[\text{deg}])$ 2: $a(90[\text{deg}]) + bz^{-1}(92[\text{deg}])$ 3: $a(150[\text{deg}]) + bz^{-1}(142[\text{deg}])$
SNR , SIR	20[dB], 0[dB]

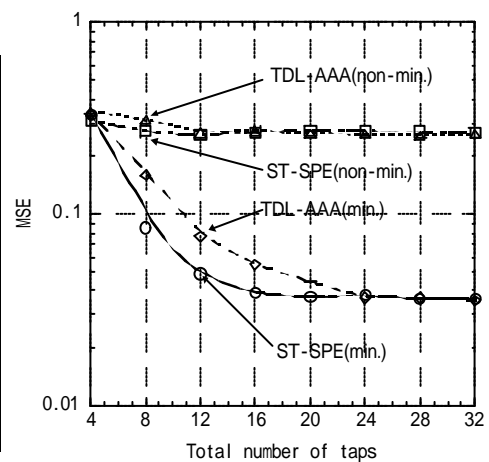

Fig.2 Comparison of MSE.

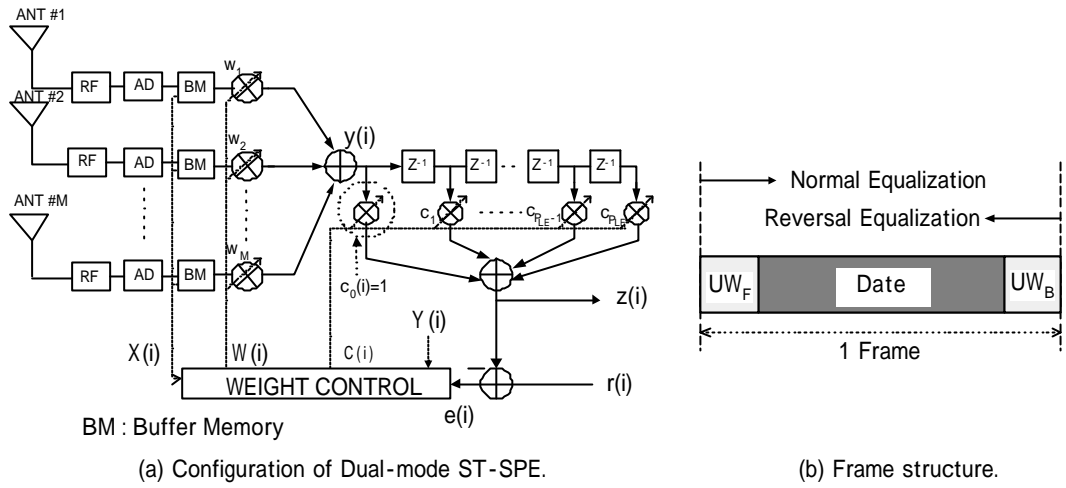

Fig.3 Dual-mode ST-SPE system.

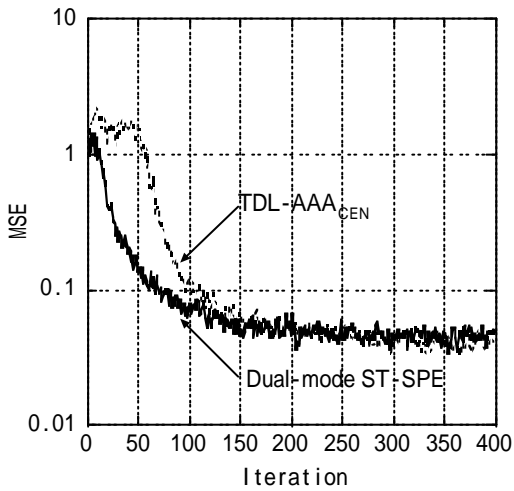

Fig.4 Convergence characteristic.

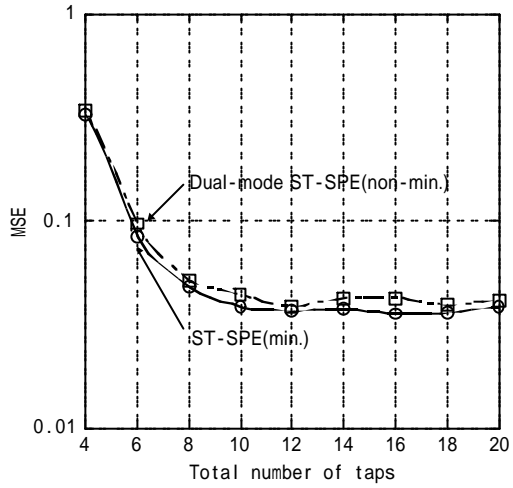

Fig.5 Comparison of MSE(ST-SPE).

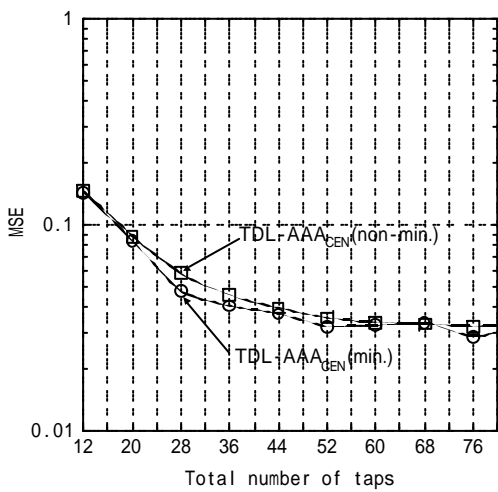

Fig.6 Comparison of MSE. (TDL-AAA\_CEN)

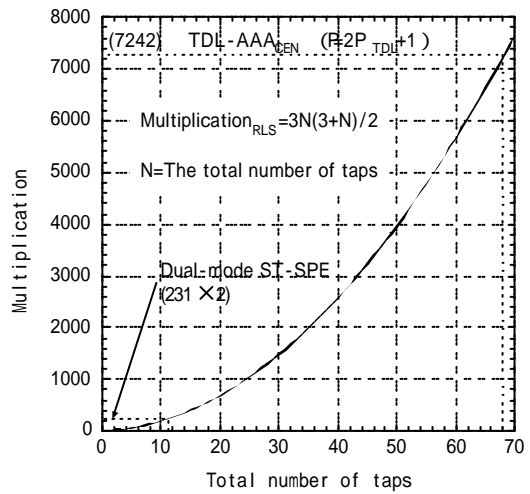

Fig.7 Comparison of the number of multiplication.