

# **Analysis of Built-in Antennas for Handset using Human (Head, Hand and Finger) Model**

**Jun ITO<sup>1</sup>, Syogo HAYASHIDA<sup>1</sup>, Hisashi MORISHITA<sup>1</sup> and Kyohei FUJIMOTO<sup>2</sup>**

<sup>1</sup>Department of Electrical Engineering, National Defense Academy  
1-10-20 Hashirimizu, Yokosuka 239-8686 Japan

Tel: +81-468-41-3810 ext. 2261, Fax: +81-468-44-5911, e-mail: [morisita@nda.ac.jp](mailto:morisita@nda.ac.jp)

<sup>2</sup>FAIS, University of Tsukuba, 3-9-1 Amakubo, Tsukuba 305-0005 Japan

## **1.Introduction**

In recent years, mobile communication systems such as cellular phone and PHS (Portable Handy phone System) have rapidly been popularized. The handset unit used in these systems trends to reduce the size and the weight. Antennas used for such handsets must also follow downsizing of the handset unit and are effected sensitively by the environment such as the handset and humanly when an operator holds the small handset at a talk position, he is act to put up the forefinger. Built-in antennas are especially required for the latest handset antenna design and are greatly influenced by the forefinger, with which the antennas are covered at a talk position. Therefore, it is important to take the effect of human body including the finger into consideration in the analysis of built-in antennas.

The electromagnetic simulators are very effective in analyzing the built-in antennas including the effect of the surrounding objects such as handset and human body, and are widely used nowadays.

In this paper, the characteristics of built-in antennas for handset in the vicinity of human body (hand, head and finger) are analyzed by the electromagnetic simulator IE3D and Fidelity and the effect of the human body on the antenna is clarified.

## **2.Antenna structure and Human model**

Two types of the built-in antenna for handset are considered and shown in Fig. 1. Fig. 1(a) shows a structure of the Planar Inverted-F Antenna (PIFA) mounted on the conducting box [1]. The handset is assumed to be about 70cc in the volume. A short pin is installed at the distance of 5.7mm from the feed point. The center frequency is 2100MHz. Fig. 1(b) shows the configuration of the folded loop antenna and the finite ground plane that represents a shielding plate used in the handset unit [2]. This antenna has a balanced and integrated structure, which is composed of a radiation element and a reactive element; these being constituted by using a two-wire transmission line, and folded at a quarter-wavelength to form a folded half-wave dipole equivalently. The antenna element is placed very close to the rectangular ground plane ( $dz=1\text{mm}$ ), which has the perimeter of about two wavelengths. The center frequency is 1860MHz.

The human model is composed of a head, hand, and finger as shown in Fig. 2. As the head model, COST 244 model is used and is the one of the normative human head model for the international standard. The head models have a spherical form with a diameter of 200mm and a cubic form with an edge of 200mm. The head model has the dielectric properties of the relative permittivity of 43.37 and the conductivity of 1.204[S/m], which correspond to a brain tissue in 2,000[MHz]. The hand model is composed of a bent rectangular prism with a volume of about 300cc. The finger model has a rectangular prism form with a volume of about 9cc, which shows the forefinger. The hand and finger model has the dielectric properties of the relative permittivity of 54 and the conductivity of 1.45 [S/m], which correspond to a muscular tissue

in 2,000[MHz].

### 3.Results

In the IE3D simulator, the number of division is 15 per a wavelength. In the FIDELITY simulator, the size of the calculation including the human body model is 270mm x 240mm x 242mm using PML for the absorbing boundary condition so that the influence of the absorbing boundary becomes small. The number of total cells is 884,862 using a nonuniform mesh (0.5 – 4 mm cell), which is one of the features of the FIDELITY simulator.

The reflection coefficient  $|S_{11}|$  characteristics are shown in Fig. 3, where (a) and (b) show that without human model and with head and hand model, respectively and (c) and (d) show that with human model including finger model located at center position and right side, respectively. The change of the frequency at which  $|S_{11}|$  becomes minimum has a similar tendency for both measured and calculated results, although there is a maximum difference of about 10dB in  $|S_{11}|$  between measured and calculated results. Therefore, it is found that the experimental human model show similar characteristics to actual human in the reflection coefficient  $|S_{11}|$ .

Fig. 4 shows the radiation patterns of the power gain (dBi) for PIFA. Though calculated results agree approximately with measured results, there is a maximum difference of about 4 dB in power gain between measured and calculated results including the human model. A cause for the difference seems to be that the human head model is not a complete sphere in the simulation. As expected, the radiation decreases when the finger model is included.

Fig. 5 shows the calculated radiation efficiency. The monopole antenna with a length of  $5/8$  wavelength, which produces smaller current flow on a conducting box, is used for comparison. The radiation efficiency of both antennas is 100% when the human model does not exist. The radiation efficiency of a PIFA is rapidly deteriorated when the hand and finger model are included.

Fig. 6 shows the calculated radiation efficiency of folded loop antenna and PIFA. To compare the radiation efficiency of folded loop antenna and that of PIFA under the same condition, PIFA mounted on the same ground plane as that of folded loop antenna is used and its radiation efficiency is calculated at the center frequency of 1.86GHz. Therefore, the radiation efficiency of PIFA here is slightly different from that of PIFA shown in Fig. 5. The radiation efficiency of both antennas declines about 40% and its difference between both antennas is 10% or more when the hand and finger model are included. It is considered that in folded loop antenna, the current of the ground plane covered with the hand model is a small due to a balanced structure, while it is large in PIFA due to an unbalanced structure.

### 4.Conclusion

The characteristics of built-in antennas for handset in the vicinity of human body (hand, head and finger) have been analyzed and the effect of the human body including the finger on the antenna has been clarified. It is found that the radiation efficiency of folded loop antenna is about 10% higher than that of PIFA due to the balanced structure. More detailed analysis is continuous subjects to be studied.

### References

- [1] K. SATO et al., "Analysis of Antennas Mounted on Portable Equipment near Human Body" J. IEICE ,vol.J79-B-11, pp.892-900, Nov.1996.
- [2] H. Morishita. Y. Kim, and K. Fujimoto, "Analysis of handset antennas in the vicinity of the human body by the electromagnetic simulator" IEICE Trans. Electron., vol.E84-C, no.7, pp937-947, July 2001.

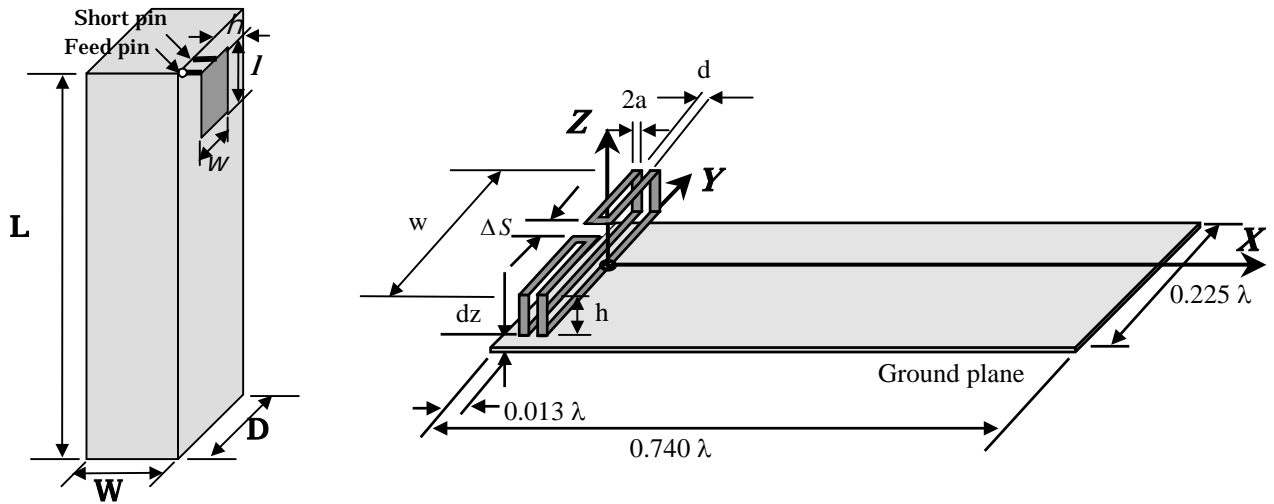

**(a) Planar Inverted F Antenna (PIFA)**

$(D=0.280, W=0.105, L=0.839,$   
 $w=l=0.147, h=0.042, f=2100\text{MHz})$

**(b) Folded Loop Antenna**

$(w=0.225, h=0.056, S=0.006,$   
 $2a=0.003, d=0.006, dz=1\text{mm}, f=1860\text{MHz})$

**Fig.1 Configuration of antenna mounted on handset**

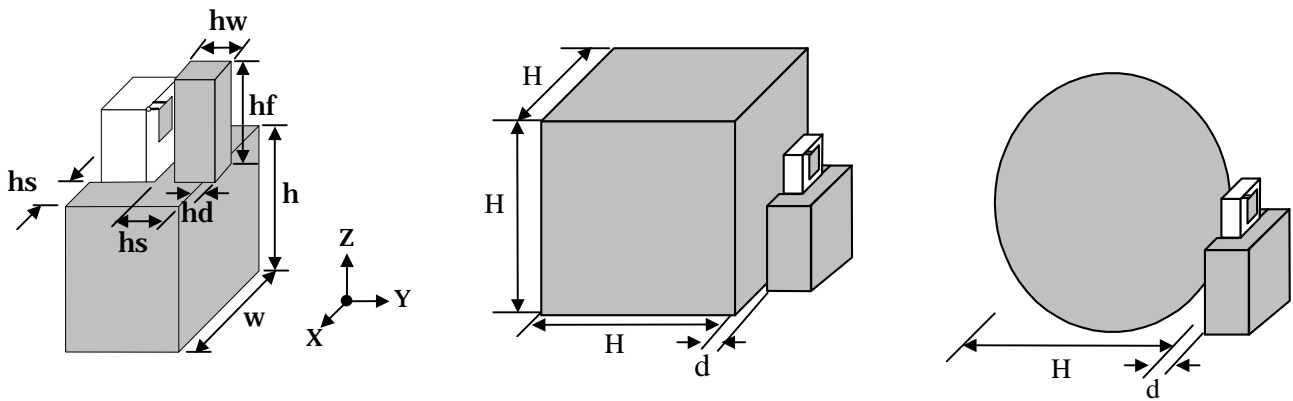

**(a) Hand and finger models and handset**

$(h=100\text{mm}, w=80\text{mm}, hs=20\text{mm},$   
 $hd=5\text{mm}, hw=15\text{mm}, hf=40\text{mm})$

**(b) Cubic head model**

$(H=200\text{mm}, d=10\text{mm})$

**(c) Spherical head model**

$(H=200\text{mm}, d=10\text{mm})$

**Fig.2 Analytical model for handset and human body**

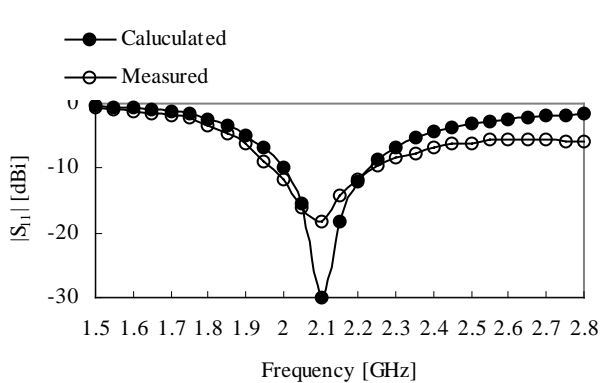

**(a) Without human model**

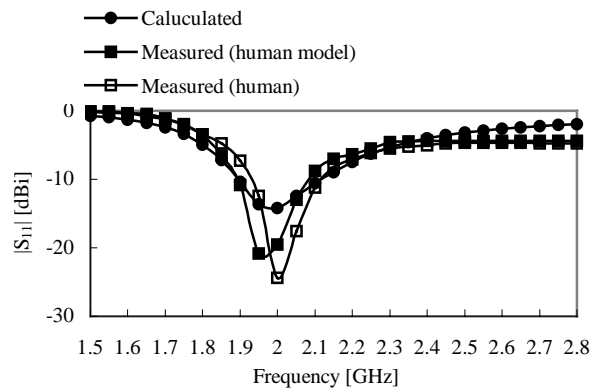

**(b) With human cubic head model and hand model**

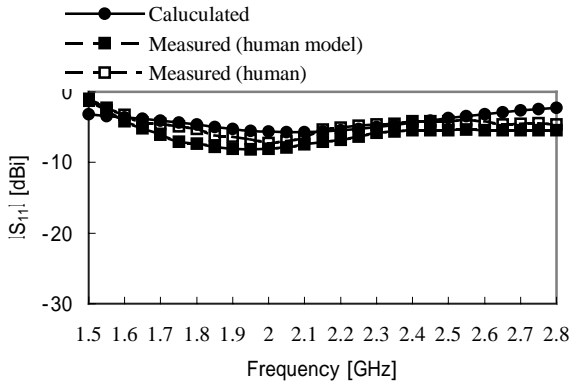

**(c) With human cubic head model and hand model including finger model located at center position**

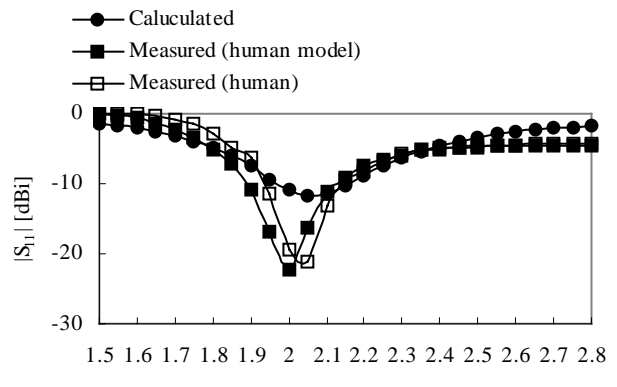

**(d) With human cubic head model and hand model including finger model located at right side**

**Fig.3 Verification of result calculated with electromagnetic simulator (reflection coefficient  $|S_{11}|$  of Planar Inverted-F Antenna)**

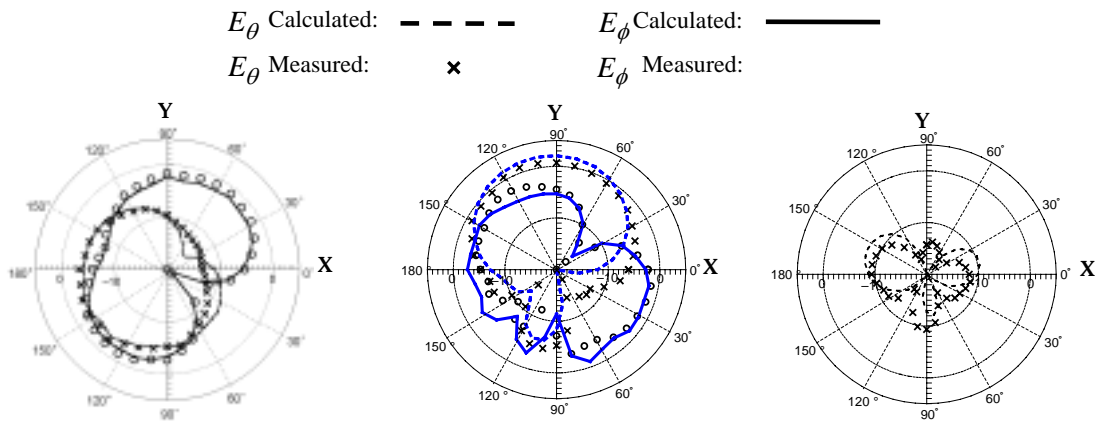

**(a) Without human model**

**(b) With spherical human head with hand model**

**(c) With human model including finger model ( $E_\theta$  pattern)**

**Fig.4 Radiation patterns of Planar Inverted-F**

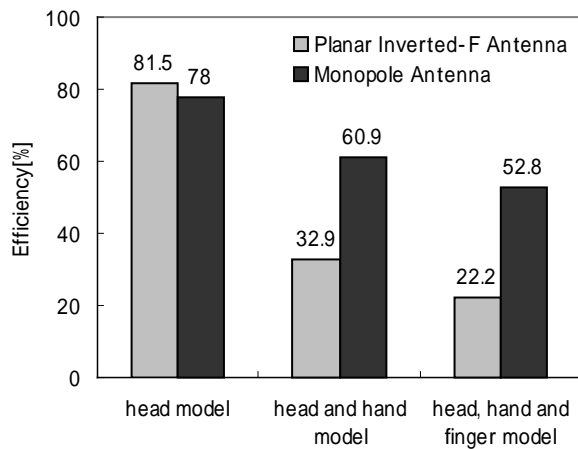

**Fig.5 Calculated radiation efficiency (comparison of Planar Inverted-F Antenna and Monopole Antenna)**

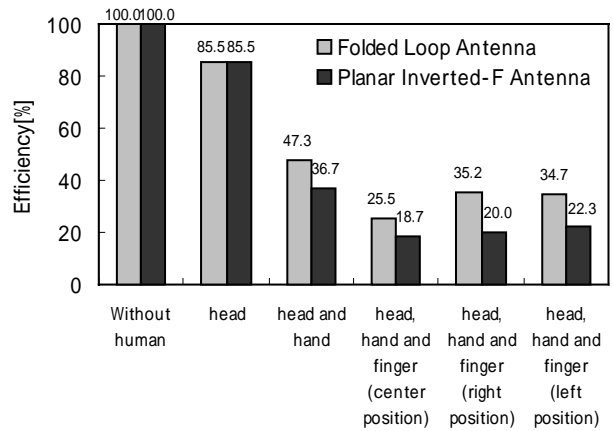

**Fig.6 Calculated radiation efficiency (comparison of Folded Loop Antenna and Planar Inverted-F Antenna)**