

ARRAY FEED SYSTEM DESIGN FOR PLANAR ARRAY FED MULTIBEAM REFLECTOR ANTENNA

Fumio KIRA, Naoki HONMA and Keizo CHO
NTT Network Innovation Laboratories, NTT Corporation
1-1, Hikari-no-oka, Yokosuka-shi, Kanagawa, 239-0847, Japan
E-mail: kira@wslab.ntt.co.jp

1. Introduction

To meet the growing demand for broadband access and diversification of communication services, for example, satellite communication, the high-gain multibeam antenna that can steer beams electrically is desired. High-gain can be achieved if the antenna uses the combination of a reflector and a small-scale array feed; the alternative, the phased array antenna, is hampered by its very large-scale BFN circuit, which increases circuit loss and cost [1]. In order efficiently to form beams with conventional reflectors, the radiating elements should be placed on a curved surface, since the focal locus of these reflectors is not straight. However, the curvature of the array surfaces and the geometric relationships of the radiating elements yield many problems that are not created by planar arrays. We previously proposed a modified multi-focus paraboloid design that enables the feed points to be well controlled [2] and showed that a high-gain scanning antenna pattern can be obtained by using a array feeding technique [3]. In general, however, implementing the ideal feed excitation coefficients is very difficult. Figure 1 shows the configuration of the conventional BFN for 4×4 array feeding. This BFN is impractical because of its excessive complexity and loss.

We propose a BFN simplification technique by applying some assumptions to these excitation coefficients. This paper demonstrates that an electrically-steerable high-gain antenna can be achieved by using a modified multi-focus paraboloid and a simplified BFN that uses couplers.

2. Concept of Modified Multi-Focus Paraboloid Design

The new multi-focus paraboloidal surface is designed to offer characteristics that are intermediate between a toroidal surface and a multi-focus paraboloidal surface [4]. A torus antenna provides uniform beams over wide scanning angles though its aperture efficiency is not high. A multi-focus paraboloid antenna provides high aperture efficiency though the characteristics of the beams vary considerably. In addition, these antennas have different feed orientations. The feeds of multi-focus paraboloid antenna illuminate the general area of the aperture's center, while those of the torus antenna illuminate different areas of the reflector.

The modified multi-focus paraboloid is equivalent to the weighted average of two or more paraboloids; each paraboloid is called a fundamental paraboloid in this paper. The paraboloid axes of the fundamental paraboloids have different orientations and each focal length is defined according to the orientation of its respective axis. This distinctive feature allows us to control the focal positions more easily. Each fundamental paraboloid is positioned so as to touch the appropriate toroidal surface that approximates desired reflector surface, and its tangent point is

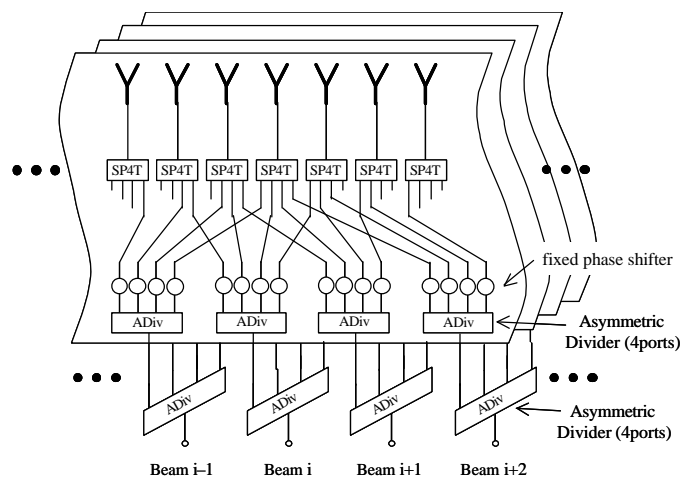

Fig. 1 Conventional BFN configuration

defined according to the orientation of its respective axis. This design feature allows the reflector to approach the torus reflector.

3. BFN Simplification Technique

Figure 2 shows the basic configuration of the planar array fed multibeam reflector antenna. The frequency is 20GHz, aperture size is A4 (623.7cm²) and desired angle for beam scanning is ± 20 degrees. The crosses in Fig. 7 show the antenna pattern characteristics obtained from a 16 element array (4 × 4, 10 mm length × 8 mm width), where the excitation coefficient of each array is optimized for better efficiency at each beam direction by using the least-square optimization method [5],[6]. The excitation coefficients of beam 0, beam 5, and beam 10 are

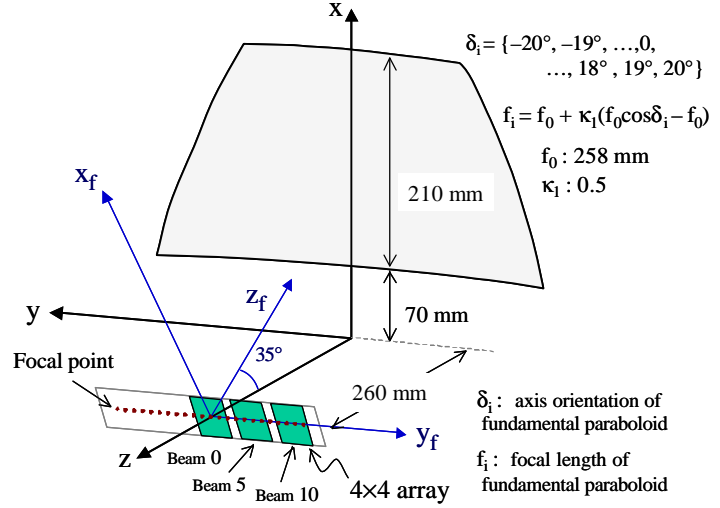

Fig. 2 Planar array fed multibeam reflector antenna.

Table 1 Excitation coefficients optimized for better efficiency.

		Beam 0				Beam 5				Beam 10			
x_f	y_f	-12 mm	-4 mm	4 mm	12 mm	28 mm	36 mm	44 mm	52 mm	68 mm	76 mm	84 mm	92 mm
15 mm		-5°	+49°	+49°	0°	+19°	+48°	+39°	0°	+12°	+17°	+17°	0°
		-20.3 dB	-14.9 dB	-14.9 dB	-20.6 dB	-22.5 dB	-14.8 dB	-15.8 dB	-18.4 dB	-19.9 dB	-14.1 dB	-15.0 dB	-17.0 dB
5 mm		+11°	+40°	+40°	+11°	+7°	+33°	+42°	+17°	-22°	+0°	+25°	+34°
		-15.4 dB	-7.4 dB	-7.4 dB	-15.4 dB	-13.8 dB	-7.1 dB	-8.6 dB	-17.1 dB	-13.6 dB	-7.5 dB	-8.9 dB	-17.5 dB
-5 mm		+26°	+43°	+43°	+26°	+5°	+32°	+52°	+69°	-41°	-4°	+39°	+109°
		-17.6 dB	-7.2 dB	-7.2 dB	-17.6 dB	-13.4 dB	-6.5 dB	-8.6 dB	-23.3 dB	-13.3 dB	-7.1 dB	-8.9 dB	-18.1 dB
-15 mm		+97°	+54°	+54°	+97°	-3°	+36°	+77°	-179°	-65°	-7°	+66°	+166°
		-33.3 dB	-13.8 dB	-13.8 dB	-33.3 dB	-20.2 dB	-12.0 dB	-14.9 dB	-21.3 dB	-17.6 dB	-12.2 dB	-13.9 dB	-15.6 dB

shown in Table 1. In this case, aperture efficiencies in the range 78% to 64% were obtained over the 40 degree scanning range. In order to make the antenna more practical, we simplify the BFN by assuming that the excitation coefficients have the following characteristics.

- The phase inclination in the direction of the X_f axis is 0.
- The amplitude ratio in the direction of the X_f axis is only defined according to the element position and not to beam orientation.
- The phase inclination in the direction of the Y_f axis is only defined according to the element position, and not beam orientation.
- The amplitude ratios $Y_f=(i \times 8 + 4)$ to $Y_f=(i \times 8 + 12)$ are stipulated when beam i and beam $i+2$ have an inverse relation.
- For each beam, the sum of the powers of the eight rightmost element powers equals the sum of the powers of the eight leftmost elements.

Assumptions a) and c) reduce the number of fixed phase shifters to about 1/4. Assumption b) reduces the number of asymmetric divider (4ports) to about 1/4. Furthermore, d) and e) enable some switches to be replaced by Couplers. In addition, to reduce the difficulty of designing the asymmetric-power divider/combiner we also assume the following.

- The amplitude distributions in the direction of the X_f axis are symmetric.

Figure 3 shows the configuration of a BFN designed according to the above assumptions. Only the transmitter design is described to simplify the explanation. This array feed system consists of 4x17 elements, fixed phase shifters, power dividers, couplers and SPDT switches. It is designed to output 14 antenna beams from 0 degrees to 20 degrees. The SPDT switches, which allow switching of odd and even number beams, are not essential. If an increase in power loss can be allowed, a power combiner could be used in place of the SPDT.

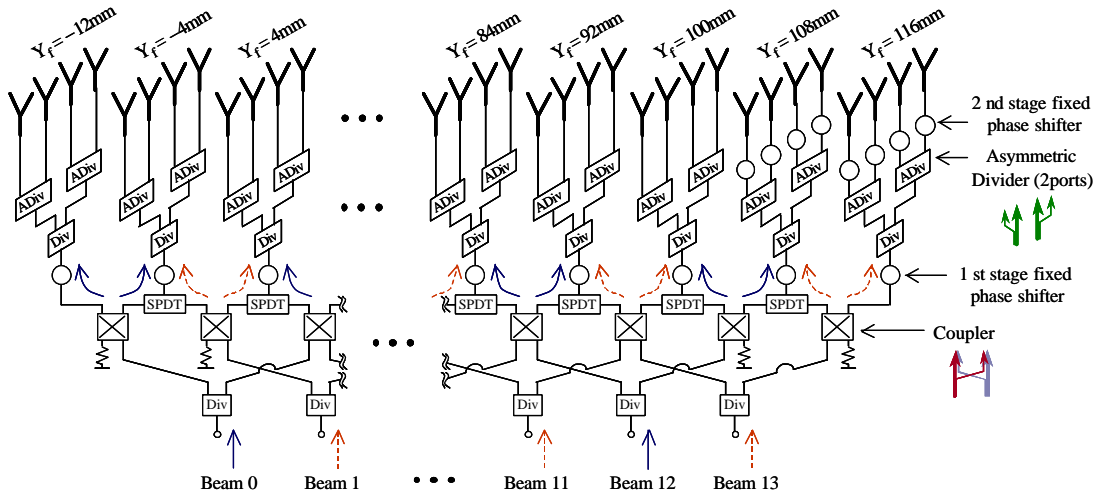

Fig. 3 Proposed BFN configuration.

4. Characteristics of Planar Array fed Multibeam Reflector Antenna

The design parameters of the proposed BFN are determined by fitting the ideal excitations. At first, we consider the phase of the center 4 elements (ideal excitation) in order to decide the value of each fixed phase shifter. Figure 4 shows that the inclination of the phase of the feed array is taken as the line of best fit through the average phase values of each element pair under ideal feed excitation. Next, we sample the sum of the powers of 4 and 8 element groups under ideal excitation, in order to decide the appropriate settings of the couplers and power dividers. Figure 5 shows these powers. The parameters for couplers are obtained from the power sum of the 8 element groups. The parameters for the asymmetric dividers are obtained from the power sum of the 4 element and 8 element groups. The complete parameter set for the proposed BFN is shown in Table 2. In order to suppress the gain deterioration at wide scanning, the values of the 2-nd stage phase shifters are determined from the 14-th ideal beam excitation. Examples of the excitation coefficients achieved by this BFN are shown in Table 3. Figure 6 shows examples of the antenna radiation patterns output by the proposed antenna design. In Fig. 6, the broken lines plot the calculation results; the HPBW of these patterns is about 3 degrees. Figure 7

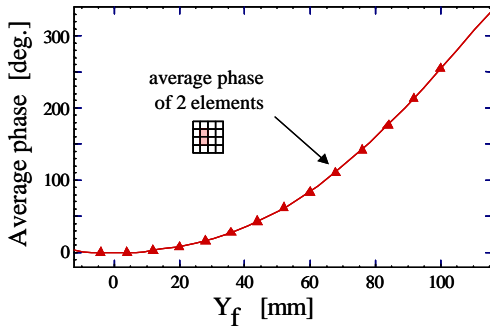

Fig. 4 Phase inclination of feed array.

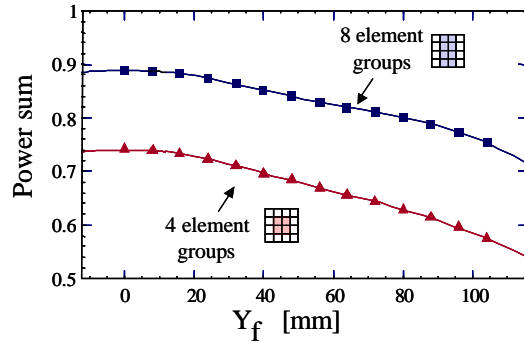

Fig. 5 Power allocation for each feed array group.

Table 3 Design parameters for proposed BFN.

Phase [deg.] (2 nd stage)	$y_f = -4$ mm	$y_f = 20$ mm	$y_f = 44$ mm													$x_f = 15$ mm	-8	-50
	-12 mm	$y_f = 12$ mm	$y_f = 36$ mm													$x_f = 5$ mm	-3	-11
Asymmetric divider [dB]		$y_f = 4$ mm	$y_f = 28$ mm													$x_f = -5$ mm	9	48
																$x_f = -15$ mm	29	93
Phase [deg.] (1 st stage)	7.7	7.8	7.7	7.7	7.6	7.5	7.3	7.2	7.1	6.9	6.8	6.6	6.5	6.3	6.2	6.2		
Coupler [dB]	9.5	9.5	9.5	9.3	9.0	8.7	8.3	8.0	7.7	7.5	7.2	7.0	6.7	6.4	6.1	5.7		

shows the variation in the aperture efficiencies and the beam orientation versus the feed location, Y_f , at 8mm intervals. The

Table 2 Excitation coefficients of proposed BFN.

		Beam 0				Beam 5				Beam 10			
$x_f \backslash y_f$		-12 mm	-4 mm	4 mm	12 mm	28 mm	36 mm	44 mm	52 mm	68 mm	76 mm	84 mm	92 mm
15 mm		+3°	0°	0°	+3°	+16°	+28°	+43°	+61°	+110°	+141°	+176°	+213°
		-23.2 dB	-14.3 dB	-14.3 dB	-23.2 dB	-22.3 dB	-14.1 dB	-14.1 dB	-21.2 dB	-20.2 dB	-13.7 dB	-13.7 dB	-19.2 dB
5 mm		+3°	0°	0°	+3°	+16°	+28°	+43°	+61°	+110°	+141°	+176°	+213°
		-16.3 dB	-7.3 dB	-7.3 dB	-16.3 dB	-15.5 dB	-7.5 dB	-7.7 dB	-14.9 dB	-14.3 dB	-8.0 dB	-8.1 dB	-13.9 dB
-5 mm		+3°	0°	0°	+3°	+16°	+28°	+43°	+61°	+110°	+141°	+176°	+213°
		-16.3 dB	-7.3 dB	-7.3 dB	-16.3 dB	-15.5 dB	-7.5 dB	-7.7 dB	-14.9 dB	-14.3 dB	-8.0 dB	-8.1 dB	-13.9 dB
-15 mm		+3°	0°	0°	+3°	+16°	+28°	+43°	+61°	+110°	+141°	+176°	+213°
		-23.2 dB	-14.3 dB	-14.3 dB	-23.2 dB	-22.3 dB	-14.1 dB	-14.1 dB	-21.2 dB	-20.2 dB	-13.7 dB	-13.7 dB	-19.2 dB

results obtained with the proposed antenna are shown as circles. The dots plotted in beam 12 and beam 13 were determined by omitting the 2-nd stage phase shifters. These figures tell us that the proposed antenna provides good aperture efficiency and homogeneous patterns over the 40 degree scanning range. Furthermore, the aperture efficiencies of 74-58% are achieved with the simplified BFN circuit, and its minimum value is only 6dB smaller than the value of the ideal BFN circuit.

4. Conclusion

We created a design approach for planar array fed multibeam reflector antennas that is a modification of the multi-focus paraboloid design method, and demonstrated the excellent performance that can be expected. The planar array feed system can avoid many of the problems associated with the use of a feed system based on a conformal array. We proposed an affordable BFN configuration by making some assumptions about its excitation coefficients, and showed that the resulting antenna provides good aperture efficiency, 74-58%.

Acknowledgment

The authors thank Dr. Masahiro Umehira for his constant encouragement and guidance. The authors also thank Dr. Toshikazu Hori of Fukui University and Hideki Mizuno of NTT DoCoMo Corporation for their helpful discussion and assistance.

References

- [1] R. J. Mailloux, The handbook of ANTENNA DESIGN, Chapter 5, IEEE electromagnetic wave series, Peter Peregrinus Ltd., 1986.
- [2] A. Vincent Mrstik and P.G.Smith, "Scanning Capabilities of Large Parabolic Cylinder Reflector Antennas with Phased-Array Feeds", IEEE Trans. vol.AP-29, May 1981
- [3] A. Kondo et al., "Reflector Design and Radiation Characteristics of a Multi-Focal Parabola Antenna", JINA'92, Nice, France, pp.271-273, November 1992
- [4] F. Kira et al., "Modified Multi-Focal Paraboloid Design for High Aperture Efficiency Multibeam Reflector Antenna", APS2002, San Antonio, Texas, 26.7, June 2002
- [5] H. J. Larson, Introduction to the Theory of Statistics, Chapter 7, John Wiley & Sons, 1973
- [6] R. Mautz and R. F. Harrington, "Computational Methods for Antenna Pattern Synthesis", IEEE Trans. Antennas Propagat., vol. AP-23, pp. 507-512, 1975

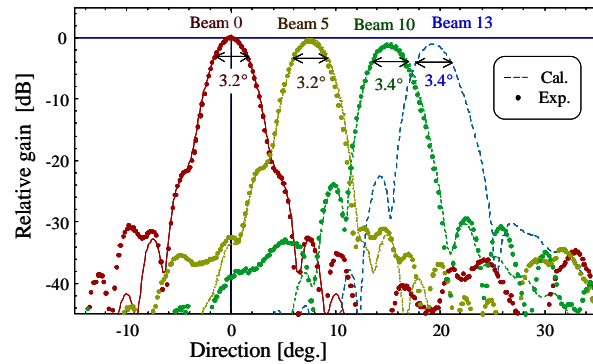

Fig. 6 Antenna Radiation patterns.

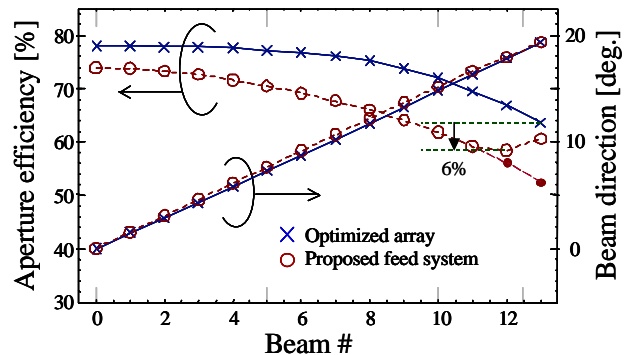

Fig. 7 Pattern characteristics