

# Numerical Simulation of Fat Dielectric Loaded Waveguide Antenna using FDTD method

Hidehisa Shiomi, Sadahiko Yamamoto

Graduate School of Engineering Science, Osaka University  
Machikaneyama-cho 1-3, Toyonaka, Osaka 560-8531, Japan  
E-mail: shiomi@ee.es.osaka-u.ac.jp

## Abstract

Recently, the high gain compact antenna for the wireless broad-band communication at millimeter-wave frequency is strongly required. It is believed the Fat Dielectric Loaded Waveguide Antenna (FDL-WGA) is one of the most promising candidate of the millimeter-wave antenna for the broad-band communication. T. Tsugawa[1] reported that FDL-WGA with the cylinder dielectric diameter of  $1.5\lambda_0$  and the cylinder dielectric length of  $1.7\lambda_0$  has the gain of 16.66dBi. This paper describes the simulation results of the FDL-WGA using FDTD method. From the consideration of the numerical results, the FDL-WGA operates like an  $2 \times 2$  array antenna with the source at the dielectric edge.

## 1 Introduction

Recently, the demand of the wireless broadband communication at millimeter-wave frequency increases with activity of digital multimedia-contents circulation. One of the problem of the millimeter-wave communication is the large transmission loss in free space. For instance, transmission loss of the 5m distance between the transmitter and the receiver is about 82dB at 60GHz. Therefore, the high gain antenna is required to compensate the large transmission loss.

The dielectric loaded planar antennas have the

high gain with simple structure. The typical structure is that the dielectric is in front of the radiator. The dielectric works like a lens and increase the antenna gain. The Fat Dielectric Loaded Waveguide Antenna is the highest gain with the compact structure most also in various dielectric loaded antennas.

## 2 FDL-WGA

The Fat Dielectric Loaded Waveguide Antenna (FDL-WGA) is rectangle waveguide aperture mounted in large ground plane, loaded with the cylindrical dielectric as shown in Fig. 1. The

cylindrical diameter  $d$  and length  $l$  are about several wavelength. The feature of the FDL-WGA is that it is compact and has high isotropic gain. For instance, in FDL-WGA which loaded the dielectric with the diameter of  $1.5\lambda_0$  and the length of  $1.7\lambda_0$  shows the gain of 16.6dBi. A dielectric rod with the diameter of  $0.5\lambda_0$  and the length of  $6-7\lambda_0$  is used in a rod antenna with the almost same gain. Furthermore, the high gain planar antenna constituted by the 64 elements FDL-WGA array was also reported[1]. This antenna with the aperture size of 288mm has the gain of a maximum of 31.9dBi at 11.85GHz.

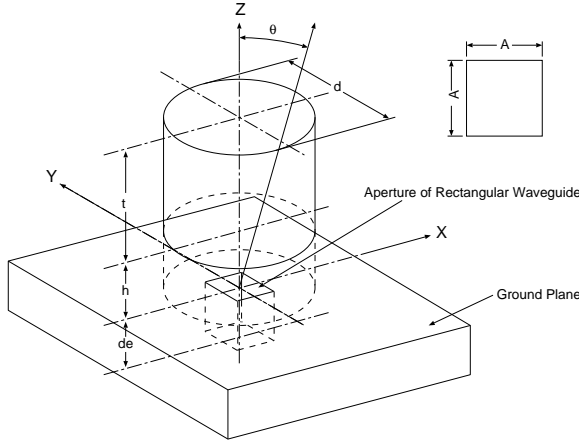

Figure 1: Fat Dielectric Loaded Waveguide Antenna

### 3 Simulation

In order to investigate behavior of the electromagnetic fields at the dielectric part of the FDL-WGA, the electromagnetic fields around an antenna was calculated using the FDTD method. The computer program of the fields computation has PML subroutine for free space boundary. The lattice scheme is the uniform orthog-

onal lattice. In this case, the shape of a dielectric was used as the rectangular parallelepiped for simplification of a simulation. A simulation model of the FDL-WGA is shown in Fig. 2. The rectangular parallelepiped dielectric was loaded on the rectangle aperture mounted in infinite ground plane. The feeding waveguide is mounted on the rectangle aperture in the opposite side of a dielectric. The  $z$  component of the electric field on the edge of the feeding waveguide was excited directly according to following:

$$E_z(y, t) = E_0(t) \sin \frac{\pi y}{a}$$

$$E_0(t) = \sin \omega t \sin \frac{\omega t}{N}$$

The frequency domain fields at 59.498GHz was calculated by having carried out discrete Fourier transform of the obtained time domain fields. The detailed simulation parameter was shown in Table 1.

The magnitude of  $z$  component of the electric field without dielectric is shown in Fig. 3. In this figure, the shade of a pixel shows the amplitude value. The cut plane  $aa'a''a'''$ ,  $bb'b''b'''$  and  $cc'c''c'''$  are indicated in Fig. 2. Similarly, the magnitude of  $z$  component of the electric field around the FDL-WGA with the dielectric size of  $10.8 \times 8.4 \times 8.4$  [mm] is shown in Fig. 4.

### 4 Consideration

From the obserbation of Fig. 4, the electromagnetic wave shows a complicated amplitude distribution due to the reflection in the border of a dielectric and air. It seems that the radiation

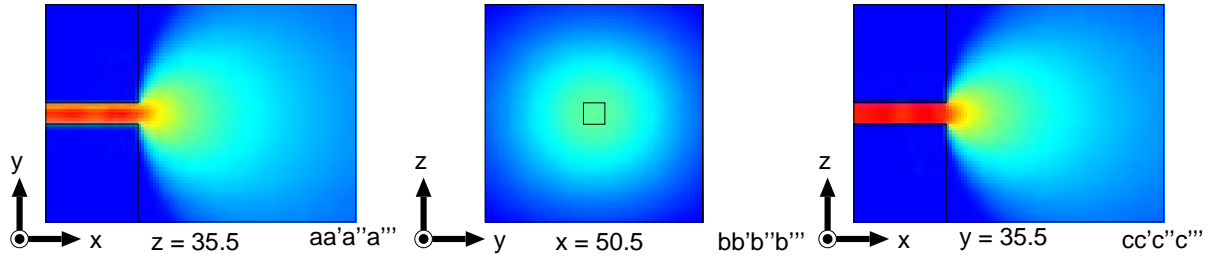

Figure 3:  $E_z$  distribution without dielectric

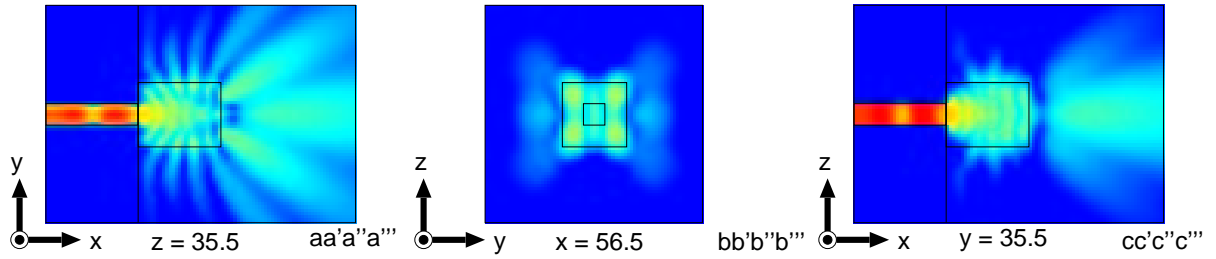

Figure 4:  $E_z$  distribution loading dielectric

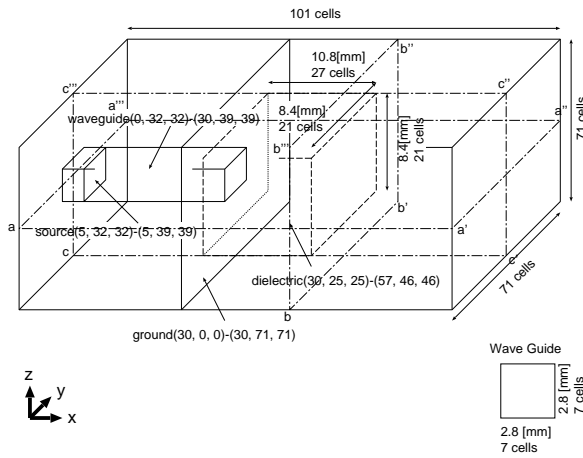

Figure 2: Simulation Model

Simulation Parameters	
time step [ps]	61.6
iteration [step]	1200
cell size [mm]	dx = 0.4
	dy = 0.4
	dz = 0.4
RDFT	
frequency [GHz]	59.498
PML	
layer [cells]	16
m	4
R	1e-16

Table 1: Detailed Simulation Parameters

wave is collected in the direction of the antenna front when a dielectric is loaded. The magnitude of the electric field on four corner of a dielectric is relatively large on  $bb'b''b'''$  plane. The phase distribution on  $bb'b''b'''$  plane is shown in Fig. 4. In this figure, the shade of the pixel shows

the angle. The phase of the electric fields at the four corner are excited by the same phase. From these results, it seems that the FDL-WGA operates like an array antenna with four point source at the dielectric corner.

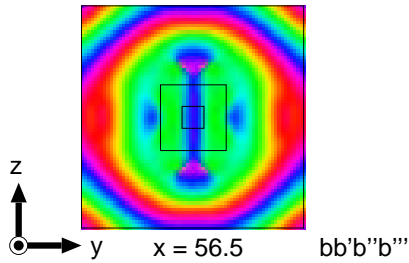

Figure 5: Phase distribution loading dielectric

## 5 Conclusion

The simulation of the FDL-WGA was carried out. The magnitude and phase distribution of the electromagnetic fields around the antenna is shown. From the computation results, the FDL-WGA operates like an array antenna.

## Acknowledgement

The authors wish to thank Dr. Tetsuo Tsugawa of ABEL Systems Incorporation, Professor Yoshihiro Sugio of Setsunan University, Dr. Koichi Ogawa and Mr. Ken Ohno of Matsushita Electric Industrial Co. Ltd. for their helpful advice. Furthermore, authors are thankful to the member of the next generation wireless communication research group of Kansai Electronic Industry Development Center which had various discussions.

## References

- [1] T. Tsugawa, Y. Sugio and Y. Yamada, "Circularly Polarized Dielectric-Loaded Planar Antenna Excited by the Parallel Feeding Waveguide Network," IEEE Transactions on Broadcasting, vol. 43, No. 2, pp. 205-212.