

Analysis of shielding enclosures based on CFRP materials

Michael Kühn
EMC-Department
AUDI AG
Ingolstadt, Germany
michael.kuehn@audi.de

Marcel Messer
EMC-Department
AUDI AG
Ingolstadt, Germany
marcel.messer@audi.de

Abstract—The main topic of this paper is the analysis of shielding enclosures based on CFRP materials. The analysis starts on material level with a determination of the electrical properties of CFRP. Also the magnetic shielding effectiveness of a CFRP material sample was measured and discussed. For the analysis on enclosure level, a test enclosure was prepared and also a numerical model for further investigations and parameter studies. At last, measurement and simulation results for parameter studies were developed and compared to an Aluminium enclosure. The varied parameter was the number of screws between the enclosure parts. A huge influence of the parameters and materials was observed in the measurement and simulation results. The simulation model could be used for a quick analysis of an enclosure based on CFRP material.

Index Terms—EMC, EMI, shielding effectiveness, composite materials, CFRP

I. INTRODUCTION

This paper deals with the analysis of shielding effectiveness for enclosures based on CFRP (carbon fibre reinforced polymer) materials. The main advantage of CFRP in comparison to conventional materials like Aluminium is the low density (CFRP: $1.6 \dots 2 \frac{\text{g}}{\text{cm}^3}$, Al: $2.7 \frac{\text{g}}{\text{cm}^3}$) and very good mechanical properties. Another important point is the great electrical conductivity of CFRP with $54.95 \frac{\text{kS}}{\text{m}} < \sigma < 285.71 \frac{\text{kS}}{\text{m}}$ [1]. CFRP is already a well known and also well used material, especially in vehicles for motor sports. For example, motor sport cars have a complete chassis based on CFRP [2]. With this experience, CFRP is also in the focus of the automotive industry, especially for electric vehicles (EV), because there is a strong correlation of weight and driving range. Nevertheless, from the EMC perspective there are very high requirements for the shielding effectiveness in the frequency domain. Such requirements for shielding effectiveness are based on the experience of the EMC specialists in the automotive industry. The requirement considered in this contribution is the so called 70/40 dB-Shielding Requirement in the frequency range $150 \text{ kHz} < f < 120 \text{ MHz}$ and was introduced by Volkswagen. Important to say, that this shielding requirement was derived with measurements on component level of the electrical field based on CISPR 25 (see [3]). The aim of this paper is separated in two parts. The first part is an analysis of the electrical and shielding properties on material level and the second is a study

of shielding effectiveness on enclosure level with numerical simulations and measurements.

II. SHIELDING EFFECTIVENESS

Shielding effectiveness (SE) is well known as the ratio of the magnitude of the incident field, to the magnitude of the transmitted field. The following formula 1 shows an example for the electrical field [4]:

$$SE = 20 \log \left(\frac{E_{\text{incident}}}{E_{\text{transmitted}}} \right) \quad (1)$$

The electrical/magnetic SE depends strongly on several parameters which can be explained by the following Fig. 1. SE was calculated with the analytical model for a spherical shield by Kaden (see [5]). The model was parameterised for Copper ($\sigma_{\text{Cu}} = 57.9 \frac{\text{MS}}{\text{m}}$) with a radius of $r = 0.5 \text{ m}$ and a thickness of $t = 1 \text{ mm}$.

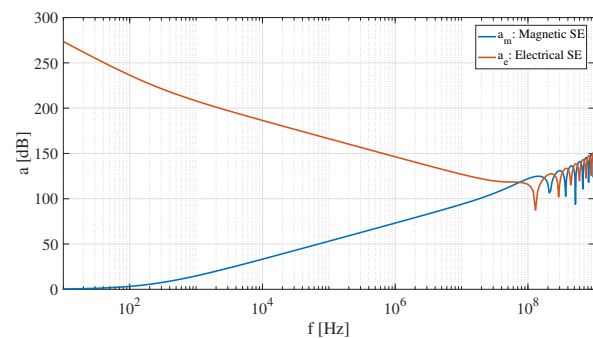

Fig. 1. Electrical and magnetic SE in the frequency domain

The blue curve represents the magnetic shielding effectiveness and for a diamagnetic material like copper the SE at $f < 10^2 \text{ Hz}$ is nearly 0 dB. This is reasoned by the permeability of copper with $\mu_r \approx 1$ respectively by non-ferromagnetic properties of the material. A ferromagnetic material like steel with a $\mu_r \gg 1$ would also shield static magnetic fields ($f = 0$). With increasing frequency, the SE also increases, because of Faraday's law of induction and Ampere's circuital law. The red curve visualises the behaviour of the electrical SE in frequency domain. Due to the effect of the Faraday cage,

the SE is very high for $f = 0$ and decreases with raising frequency. At the intersection of both curves, we can observe the transition from near field to far field behaviour, or in other words, when the dimension of the shield corresponds with the wavelength. So, the left side of the intersection describes the near field phenomena where a separated consideration of the electrical and magnetic field values is possible and helpful. On the right side it is necessary to consider both field values as an electromagnetic wave.

III. ANALYSIS OF CFRP ON MATERIAL LEVEL

In this paper a CFRP material from Bond-Laminates GmbH was used with the name Tepex dynalite 201-C600(x)/45% (see [6]). The material consists of several layers of carbon fibre layers (90° woven, 50%) with a non conductive matrix of Polyamid 6.6 (PA 6.6) and a thickness of $t = 2$ mm.

A. Electrical conductivity

In [7] is a study about the electrical conductivity of CFRP in fibre direction (x - y) and through the material (x - z). There is a huge discrepancy between the electrical conductivity in fibre direction and through the different layers (z -direction). The conductivity in z -direction is $\sigma_{CFKz} \approx 0.41 \frac{S}{m}$ and in fibre direction $\sigma_{CFKx,y} \approx 12.54 \frac{KS}{m}$. The value of the electrical conductivity in fibre direction varies from the above given values by [1], this could be reasoned with variations in the quality of the material sample (MUT) and deviations in the fabrication process. In comparison to Aluminium with an electrical conductivity of $\sigma_{Al} = 35.9 \frac{MS}{m}$ found in [8] is CFRP significant lower. As described above, the electrical conductivity is a major parameter for the shielding effectiveness.

B. Shielding effectiveness

There are several publications with measurement results of CFRP materials, e.g. in [9] for the GHz-range with a parameter study of sheet thickness and volume fraction. In [10] are shielding effectiveness measurement results of CFRP with ASTM D4935 procedure. This measurement procedure is based on a coaxial cell with the material sample placed perpendicular to the inner and outer conductor. In the GHz-regime is according to the results a SE of > 40 dB achievable. As described above in section II the magnetic shielding effectiveness, especially in the lower frequency range ($f < 1$ MHz), is even more interesting than the electrical SE. So, a measurement procedure, the so called Coil-Method, for the SE (similar to [11]) was used, which is detailed described in [12]. The frequency range was defined with $1 \text{ kHz} < f < 300 \text{ kHz}$ to measure the magnetic shielding effectiveness. The following Fig. 2 shows the measurement result with the Coil-Method for the above described CFRP material sample (MUT) in comparison to an Aluminium MUT (thickness: $300 \mu\text{m}$).

As expected, the magnetic shielding effectiveness of the CFRP MUT was very low, due to the low conductivity of the tested CFRP material. The SE of the Aluminium MUT was significant higher and shows the expected behaviour from Fig. 1.

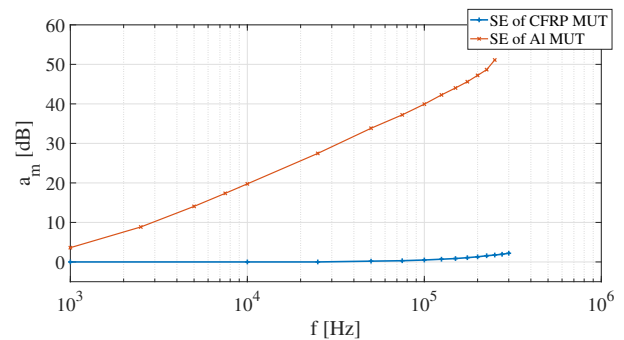

Fig. 2. Magnetic SE of CFRP and Al material sample

IV. MEASUREMENT PROCEDURE FOR SHIELDING EFFECTIVENESS ON ENCLOSURE LEVEL

A modification of the measurement procedure in [13] must be done for the low frequency range; measurement of the electrical field instead of the magnetic field. So, a rod antenna was used for this frequency range.

To determine the shielding effectiveness of an enclosure it is necessary to perform three measurements:

- Noise measurement (without enclosure and 50Ω termination)
- Reference measurement (without enclosure or without cover part)
- Shielded measurement (with enclosure)

With the noise and the reference measurement it is possible to determine the measurement range of the setup. Shielding effectiveness can then be calculated with the reference and the shielded measurement. For the measurements in this paper, a self-built monoconic antenna was used with a measurement range > 60 dB in the desired frequency range $150 \text{ kHz} < f < 1 \text{ GHz}$. The antenna is depicted in Fig. 3.

V. ANALYSIS OF CFRP ON ENCLOSURE LEVEL

This chapter describes the preparation of the test enclosure for the shielding effectiveness measurements and the numerical model for the corresponding simulations.

A. Preparation of test enclosure

The test enclosure is based on the geometry depicted in Fig. 3 and consists of three different parts with the dimensions (L, W, H) of 30 cm, 30 cm and 20 cm. The area of contact is 3 cm wide and covered with an insulation material. The material of this test enclosure is the same CFRP material described in section III and the insulation material is Polyamide 6.6 (thickness d : 13.5 mm). The insulation material was also needed to adjust the distance between the enclosure parts. The parts of the enclosure can be connected with M3 screws from the upper part and inlets in the bottom part.

B. Numerical model for shielding effectiveness

The measurement of the shielding effectiveness of an enclosure is very time consuming, especially by greater parameter studies. So, it was reasonable to develop a simulation model

with CST Microwave Studio to determine the shielding effectiveness. As described above, the model consists of three different parts: cover, bottom and insulation. CFRP can be modelled with the material type "thin panel" and the thickness is defined by the number of desired layers. The screws for the connection of the cover and the bottom were modelled with metallic cylinders and attached to the cover and bottom part of the enclosure. To determine the shielding effectiveness of the test enclosure, additionally an exact model of the monoconic antenna respectively the field source was needed. An exploded view of the simulation models for the test enclosure and the monoconic antenna is visualised in Fig. 3.

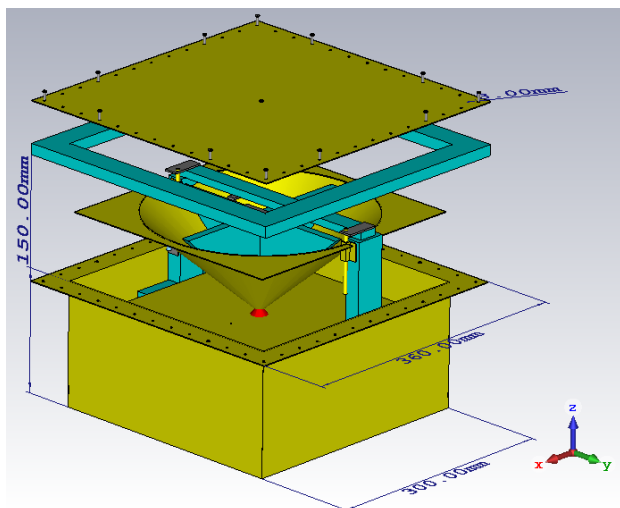

Fig. 3. Exposed view of the Simulation model in CST Microwave Studio for the SE

The shielding effectiveness can be calculated, similar to the measurement (see section IV), with electrical field probes outside of the enclosure for two different cases (reference and shielded).

VI. MEASUREMENT AND SIMULATION RESULTS

This chapter presents the measurement and simulation results of the shielding effectiveness for a CFRP and an Aluminium enclosure. For both enclosures, the number n of connection points (M3 screws) was varied and the distance $d = 13.5$ mm was constant.

VII. DISCUSSION OF THE MEASUREMENT AND SIMULATION RESULTS

The measurement results for $d = 13.5$ mm and $n = 0$ (see Fig. 4 and Fig. 7) of the Aluminium and CFRP enclosure show a very low shielding effectiveness. This is reasoned by the non-existing connection between the cover and bottom part of the enclosure, so the Faraday cage did not work properly. The simulation model did not match well with the measurement, due to simplifications and inaccuracies by the test enclosure. For the second case $d = 13.5$ mm and $n = 4$ in Fig. 5 and Fig. 8, the electrical SE is even higher and on the same level for both enclosures. This is very interesting, especially

by comparing the magnetic SE on material level (see Fig. 2) of CFRP and Aluminium. The simulation for the Aluminium and CFRP enclosure also shows a deviation by the points of resonances in the spectrum. But for a quick analysis the simulation can be used to get an overview of the shielding performance of the desired material on enclosure level. The last case $d = 13.5$ mm and $n = 12$ in Fig. 6 and Fig. 9 is comparable with the previous case $d = 13.5$ mm and $n = 4$. For this case the simulation model matches quite better with the points of resonances in both spectra. The calculation of the shielding effectiveness for the Aluminium enclosure took about one hour on a normal performance computer.

VIII. CONCLUSION

The analysis started on material level with the discussion of the electrical properties of CFRP. The conductivity of the used material sample is significantly lower than the conductivity of Aluminium. Due to that, also the magnetic shielding effectiveness of the MUT is very low, as shown by the measurement with the coil method. At next, the analysis was extended to the enclosure level with a definition of a test enclosure for shielding measurements (see Chapter V-A) and the preparation of a numerical model in CST Microwave Studio (see Chapter V-B). Also the measurement procedure for shielding effectiveness based on [14] was discussed and adopted according to the 70/40 dB-Shielding Requirement. After this, several measurement and simulation results for an Aluminium and CFRP enclosure with varied parameters were presented and discussed in chapter VI. The presented simulation model can be used for a quick estimation of the shielding performance for different enclosures based on conventional or CFRP materials. Also interesting is the distinction of the magnetic and electrical shielding effectiveness on material and enclosure level. As shown, there was a huge discrepancy between the magnetic SE in the frequency range $1 \text{ kHz} < f < 300 \text{ kHz}$ and the electrical SE in the upper frequency range (Faraday cage). By that, dimensioning of an enclosure for shielding applications depends strongly on the field problem. The right amount of shielding, on the right place and with consideration of the right field value.

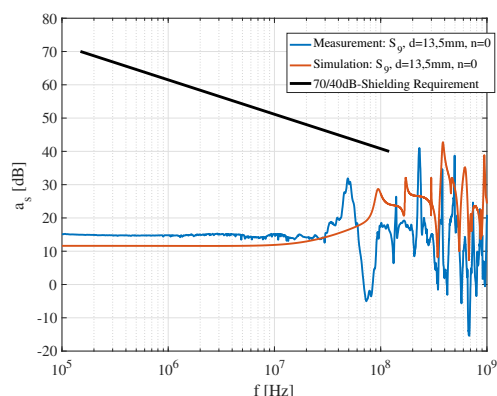
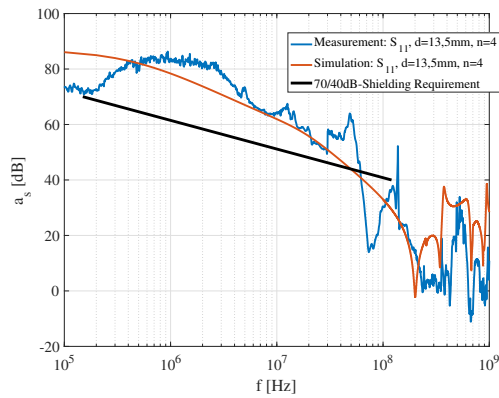
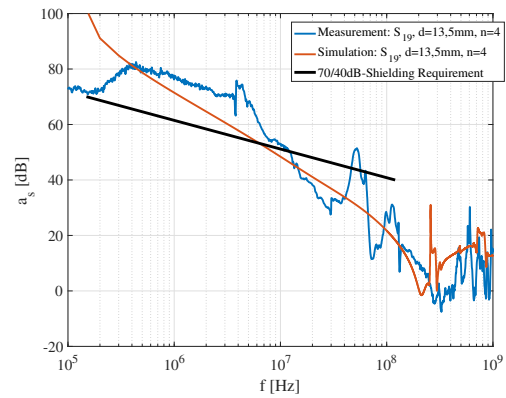
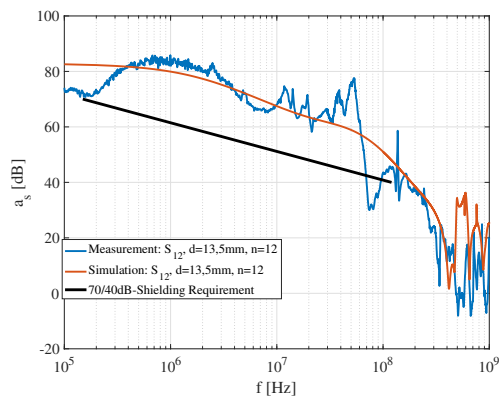
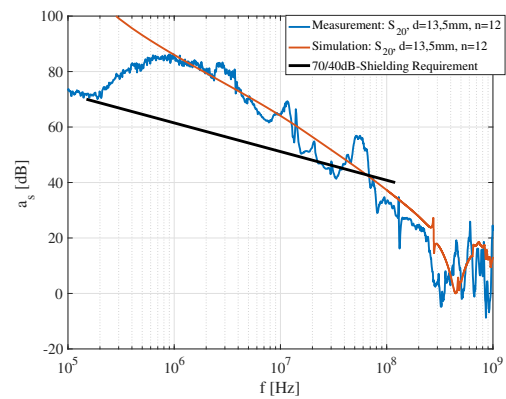
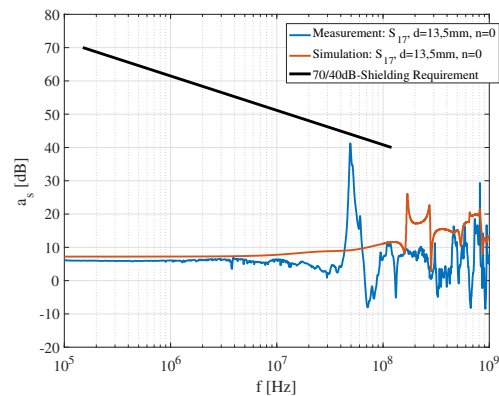

Fig. 4. SE of Al Enclosure $d = 13.5$ mm, $n = 0$

Fig. 5. SE of Al Enclosure $d = 13.5$ mm, $n = 4$ Fig. 8. SE of CFRP Enclosure $d = 13.5$ mm, $n = 4$ Fig. 6. SE of Al Enclosure $d = 13.5$ mm, $n = 12$ Fig. 9. SE of CFRP Enclosure $d = 13.5$ mm, $n = 12$ Fig. 7. SE of CFRP Enclosure $d = 13.5$ mm, $n = 0$

REFERENCES

- [1] V. Safarova and J. Gregr, "Electrical Conductivity Measurement of Fibers and Yarns," in *7th International Conference TEXSCI 2010*, 2010.
- [2] H. Schürmann, *Konstruieren mit Faser-Kunststoff-Verbunden*, ser. VDI-Buch. Springer Berlin Heidelberg, 2005.
- [3] CISPR 25, "Vehicles, boats and internal combustion engines - radio disturbance characteristics - limits and methods of measurement for the protection of on-board receivers," Ed. 3 2008.
- [4] J. Gooch and J. Daher, *Electromagnetic Shielding and Corrosion Protection for Aerospace Vehicles*. Springer New York, 2010.
- [5] H. Kaden, *Wirbelströme und Schirmung in der Nachrichtentechnik*, ser. Technische Physik in Einzeldarstellungen. Springer, 1959.
- [6] Bond-Laminates, "Materialdatenblatt Tepex dynalite 201-C600(x)/45%," 2014.
- [7] M. Kühn, W. John, and R. Weigel, "Analytical calculation of intrinsic shielding effectiveness for isotropic and anisotropic materials based on measured electrical parameters," *Advances in Radio Science*, vol. 12, pp. 83–89, 2014.
- [8] AlCuMet GmbH & Co. KG, "Datenblatt Al99,5 - EN AW-1050A," 2014.
- [9] J. Fouladgar, G. Wasselynck, and D. Trichet, "Shielding and Reflecting Effectiveness of Carbon Fiber Reinforced Polymer (CFRP) Composites," in *Proceedings of the 2013 International Symposium on Electromagnetic Theory*, 2013.
- [10] S. Greco, A. Tamburrano, A. D'Aloia, R. Mufatti, and M. S. Sarto, "Shielding effectiveness properties of carbon-fiber reinforced composite for hifv applications," in *International Symposium on Electromagnetic Compatibility - EMC EUROPE*, 2012, pp. 1–6.
- [11] IEEE-299-2006, "IEEE Standard Method for Measuring the Effectiveness of Electromagnetic Shielding Enclosures," 2006.
- [12] M. Kühn, "Auswirkungen der Kontaktierung von isotropen und anisotropen Materialien auf die elektromagnetische Schirmdämpfung von Gehäusen," Dissertation, Technische Fakultät der Friedrich-Alexander-Universität Erlangen-Nürnberg, 2018.
- [13] IEC 61000-5-7:2001, "Electromagnetic compatibility (EMC) - Part 5-7: Installation and mitigation guidelines; Degrees of protection provided by enclosures against electromagnetic disturbances (EM-code) (IEC 61000-5-7:2001)," 2001.
- [14] DIN EN 61000-5-7, "Elektromagnetische Verträglichkeit Teil 5-7: Installationsrichtlinien und Abhilfemaßnahmen - Schutzarten durch Gehäuse gegen elektromagnetische Störgrößen," 2001.