

A CONSIDERATION ON APPARENT ANTENNA EFFICIENCY OF MF GROUNDED BROADCASTING ANTENNAS

Naoki INAGAKI , Daisuke ITATSU and Nobuyoshi KIKUMA

Department of Electrical and Computer Engineering, Nagoya Institute of Technology,
Gokiso-cho, Showa-ku, Nagoya-shi 466-8555 Japan
E-mail : inagaki@elcom.nitech.ac.jp

1 Introduction

A monopole grounded antenna is a standard medium frequency broadcasting antenna. During its long history, the design of the earth structure has had to rely on the empirical knowledge, and there is still a dispute on the necessary size of the earth structure and so forth. This is due to the difficulties in the theoretical analysis, where the effect of real grounds have to be included.

The authors have treated the corresponding boundary value problems, and have shown the solutions by full wave analysis with somewhat simplified modeling. The first one treated the case with negligibly small earth, where the voltage source is directly connected to the ground[1], The second one treated the case of having an earth of flat disc[2, 3]. This paper treats a more realistic case of having radial earth on the ground as shown in Fig. 1, and presents a full wave analysis to this structure to obtain the current distribution, the near field etc., and discusses the apparent antenna efficiency which is dependent on the antenna height, earth size, and the electrical properties of the ground.

2 Green's Function

For the antenna structure shown in Fig. 2, we express the currents on the monopole surface \mathbf{J}_a [A/m²] and on the radial earth \mathbf{J}_r [A/m²] as

$$\mathbf{J}_a = \hat{\mathbf{z}} \frac{1}{2\pi a} f(z) \delta(\rho - a), \quad \mathbf{J}_r = \hat{\boldsymbol{\rho}} \frac{1}{2\pi \rho} g(\rho) h(\phi) \delta(z) \quad (1)$$

where $h(\phi)$ is a function for the radial earth with width $\rho\Delta\phi$ [λ] and the number N as shown in Fig. 3, as follows.

$$h(\phi) = \begin{cases} 1 & \left(\phi_i - \frac{\Delta\phi}{2} \leq \phi \leq \phi_i + \frac{\Delta\phi}{2} \right) \\ 0 & (else) \end{cases} \quad (2)$$

Applying the method of equivalent circuit for multi-layered medium[4], the electromagnetic fields are Fourier transformed, and the 3D structure of Fig. 1 can be replaced by the 1D equivalent circuit in the spectral domain as shown in Fig. 4. The electric field is obtained via the current I_m and the voltage V_ρ , and the Green's functions are defined for the electric field $\overline{\mathbf{E}}$ with z component and ρ component as

$$\overline{\mathbf{E}}_z = -\frac{p}{\omega\epsilon_0} I_m = \overline{G}_{zz} f(z') + \int_0^\infty g(\rho') \overline{G}_{z\rho} d\rho', \quad \overline{\mathbf{E}}_\rho = V_\rho \cos(\phi - \phi') = \overline{G}_{\rho z} f(z') + \int_0^\infty g(\rho') \overline{G}_{\rho\rho} d\rho', \quad (3)$$

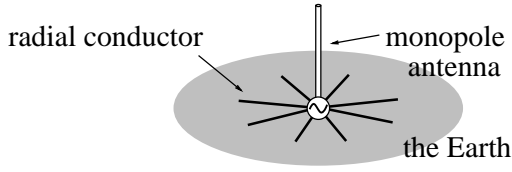

Figure 1: Monopole antenna with radial earth

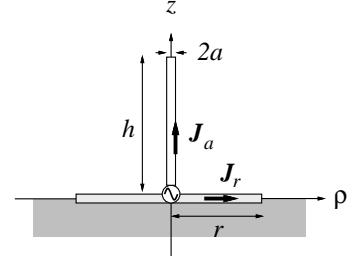

Figure 2: Geometry and coordinates of the problem

where \overline{G}_{zz} and $\overline{G}_{z\rho}$ denote the contributions of the currents \overline{J}_a and \overline{J}_r to the electric field of z component, respectively, and $\overline{G}_{\rho z}$, $\overline{G}_{\rho\rho}$ the contributions of the currents \overline{J}_a , \overline{J}_r to the electric field of ρ component. Performing the inverse Fourier transform to these four Green's functions in the spectral domain, we obtain the Green's function in the real space domain.

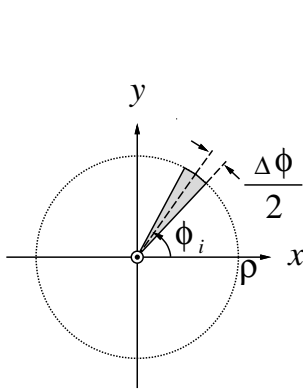

Figure 3: The function $h(\phi)$

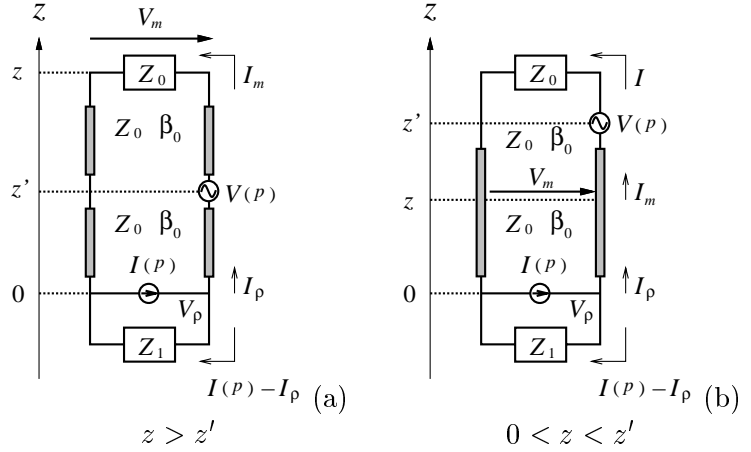

Figure 4: equivalent circuit

3 MoM Analysis

The moment method of Galerkin procedure with the triangular pulse functions as both the expansion and the weighting functions has been applied to the integral equation in terms of the four Green's function. The four impedance matrices, $[Z^{11}]$, $[Z^{12}]$, $[Z^{21}]$, and $[Z^{22}]$ are obtained corresponding to G_{zz} , $G_{z\rho}$, $G_{\rho z}$, and $G_{\rho\rho}$, respectively.

The intervals including the feeding point are characterized by the impedance matrix $[Z^{10}]$, $[Z^{20}]$, $[Z^{01}]$, $[Z^{02}]$, and the feeding point by the impedance matrix $[Z^{00}]$. The resultant matrix equation can be solved similarly as in [2] to give the currents on both the monopole and the radial earth.

4 Near Field Calculation

The input power to the antenna is divided in two components, the ground wave and the spatial wave. It is the spatial wave component to which the directive pattern is defined, but it is the ground wave component that is useful in the broadcasting services. The effectively radiated ground wave cannot be characterized by the ordinary defined antenna efficiency, and the *apparent antenna efficiency* has been introduced. The apparent antenna efficiency is the key parameter which decides the effective service area and can be obtained by experiments.

Before discussing about the apparent antenna efficiency conventionally determined by experiments, it will be desirable to see how the field exists near the antenna.

Fig. 5 and Fig. 6 show the distance dependence of the near field with the number of the radial earths N and the ground conductivity σ as parameters, respectively. The abscissa ρ is the distance from the antenna to the field observation point in wavelength (λ), and the input power P_{in} is 10 [W]. $\rho = 3.3$ equals 1 [km] in this case where $f=1$ MHz. The field decays monotonically for $\rho > 0.25\lambda$, the radial earth radius. It is observed that the distance dependence obeys roughly the ρ^{-1} and $\rho^{-1.5}$ rules when the conductivity is large and small, respectively.

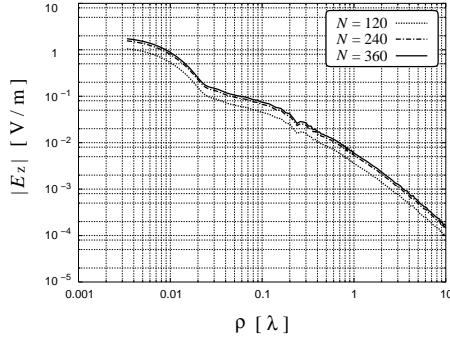

$h = 0.25\lambda$, $r = 0.25\lambda$, $f = 1$ MHz, $\sigma = 10^{-4}$ S/m
 $\epsilon_s = 10$, $\Omega = 10$, $V_{\text{in}} = 1$ V, $P_{\text{in}} = 10$ W

Figure 5: Near field (parameter : N)

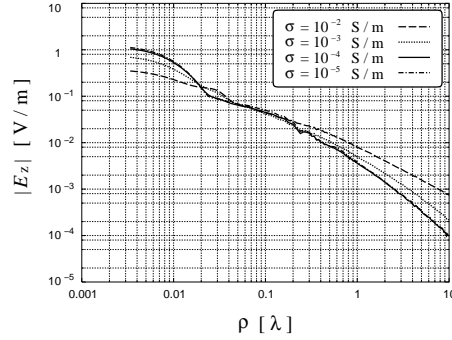

$h = 0.25\lambda$, $r = 0.25\lambda$, $f = 1$ MHz, $\sigma = 10^{-4}$ S/m
 $\epsilon_s = 10$, $\Omega = 10$, $V_{\text{in}} = 1$ V, $P_{\text{in}} = 10$ W

Figure 6: Near field (parameter : σ)

5 Apparent Antenna Efficiency

Let the electric field intensity at the point 1 km apart from the transmitting antenna be E_0 when the ground is assumed to be perfectly conducting and the input power is P ($= I_0^2 R_r$) [kW], and let it be E_d if the antenna is replaced by elementary monopole under the same situation. Then the antenna gain G is expressed as

$$G = \left(\frac{E_0}{E_d} \right)^2, E_d = 300\sqrt{P} \text{ [mV/m]}. \quad (4)$$

Next, let the electric field intensity be reduced to E_1 from E_0 . Then the apparent antenna efficiency η_a is defined and calculated as

$$\eta_a = \left(\frac{E_1}{E_d} \right)^2 = G \left(\frac{E_1}{E_0} \right)^2 = \left(\frac{E_1}{300\sqrt{P}} \right)^2 \times 100 \text{ [%]}. \quad (5)$$

As the near field distance dependence can be approximated by ρ^{-1} for the ground with sufficiently large conductivity, the electric field at $d = 1$ km for the input P_{in} can be calculated from the electric field E_z which is obtained from the measurement at the closer points from the transmitting antenna as

$$E_m = E_z d \sqrt{\frac{P}{P_{\text{in}}}} \text{ [mV/m]} \quad (6)$$

Fig. 7 and Fig. 8 shows η_a vs. antenna height with the number N and the length, of the radial earth, as parameters, respectively.

Fig. 9 shows η_a vs. the radial earth length with the antenna height as the parameter. η_a increases as the earths lengthen for $r < 0.2\lambda$, but decreases for $r > 0.2\lambda$ to the constant value after $r = 0.6\lambda$. Fig. 10 shows η_a vs. the conductivity σ of the ground with the relative permittivity ϵ_s of the ground as parameter. η_a becomes minimum where σ is a little bit smaller than $\sigma_c = 2\pi f \epsilon_0 \epsilon_s$ which gives the displacement current equal in magnitude as the conduction current.

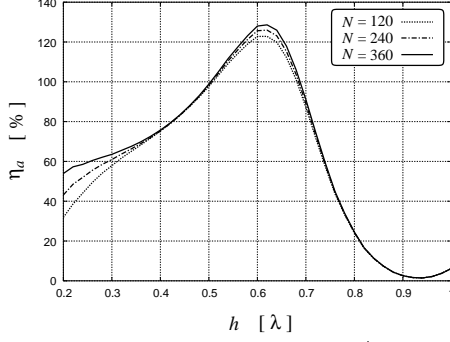

$$r = 0.25\lambda, f = 1 \text{ MHz}, \sigma = 10^{-4} \text{ S/m}$$

$$\varepsilon_s = 10, d = 1000 \text{ m}, \Omega = 10$$

Figure 7: Apparent antenna efficiency vs. antenna height (parameter : N)

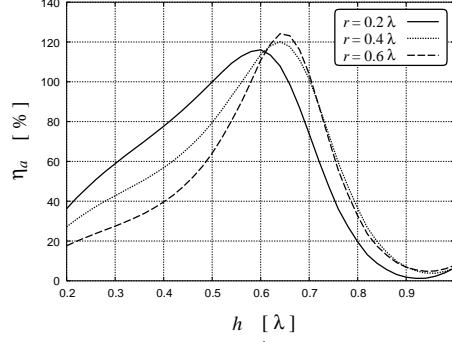

$$f = 1 \text{ MHz}, \sigma = 10^{-4} \text{ S/m}, \varepsilon_s = 10$$

$$N = 120, d = 1000 \text{ m}, \Omega = 10$$

Figure 8: Apparent antenna efficiency vs. antenna height (parameter : r)

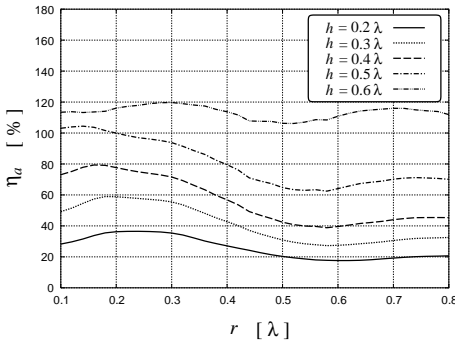

$$f = 1 \text{ MHz}, \sigma = 10^{-4} \text{ S/m}, \varepsilon_s = 10$$

$$N = 120, d = 1000 \text{ m}, \Omega = 10$$

Figure 9: Apparent antenna efficiency vs. radial earth length (parameter : h)

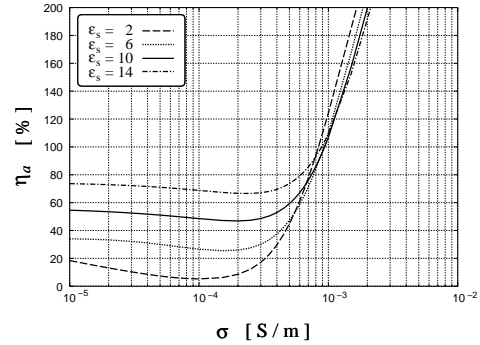

$$h = 0.25\lambda, r = 0.25\lambda, f = 1 \text{ MHz}$$

$$N = 120, d = 1000 \text{ m}, \Omega = 10, V_{in} = 1 \text{ V}$$

Figure 10: Apparent antenna efficiency vs. ground conductivity (parameter : ε_s)

6 Conclusion

The full wave analysis is presented for the monopole antenna having a radial earth on the Earth, with emphasis on obtaining the apparent antenna efficiency. It has been found that as the number of radial earths increased the results approach those given by the earth structure of conducting disk and the apparent antenna efficiency improved. It has also been found that the radius of the radial earth need not be as large as a half wavelength for the optimum apparent efficiency to be achieved.

The authors would like to thank Dr. Ohmaru of Sumitomo Electric Industries Ltd. for his guidance at the initial stage of the project.

References

- [1] Kinsaku NAKAGAWA and Naoki INAGAKI : "Theoretical Analysis of a Grounded Monopole Antenna", Trans. IECE Vol.63-B No.2 p.97 (1980)
- [2] Aki YUASA, Daisuke ITATSU, Naoki INAGAKI and Nobuyoshi KIKUMA : "Theoretical Analysis of a Monopole Antenna having an Earth on the Ground", Trans. IEICE, Vol. J82-B, No.12, pp.2320-2328(1999)
- [3] Daisuke ITATSU, Aki YUASA, Naoki INAGAKI and Nobuyoshi KIKUMA : "Theoretical Analysis of a Monopole with Conducting Disk on the Ground", Proc. ISAP'2000, Vol.3, pp.1315-1318(2000)
- [4] Naoki INAGAKI : "A Method of Analyzing Electromagnetic Field in Multi-layered Medium by Equivalent Circuit", Trans. IECE Vol.60-B No.6 p.445 (1977)