

An Accurate Propagation Path Model Obstructed by a Blocking Vehicle for Inter-Vehicle Communications at 60GHz

Atsushi YAMAMOTO, Koichi OGAWA,
Tetsuo HORIMATSU*, Akihito KATO** and Masayuki FUJISE**

Matsushita Electric Industrial Co., Ltd. Devices Development Center
1006, Kadoma, Osaka, 571-8501 Japan
Tel 06-6900-9613, E-mail a-ya@drl.mei.co.jp

*Fujitsu Ltd.

**Communications Research Laboratory

1. Introduction

In recent years, there have been many researches and development works on intelligent transport systems (ITS). Especially, the inter-vehicle communications (IVC) at 60GHz has been attracting a lot of attention. The IVC in the millimeter-wave band can provide multimedia communications between vehicles and realize the automatic driving such as Automated Highway Systems (AHS).

Propagation characteristics of the IVC system in the 60GHz band are being studied [1]-[3]. In the non line-of-sight (NLOS) case obstructed by a blocking vehicle, a two-ray model, comprising a ray reflected from a surface of the road passing through a space under the vehicle and a ray diffracted from the top of the vehicle, permits to predict approximate propagation characteristics [3]. In this model, the only two significant rays are found out from among a number of rays that are resulted from complex propagation phenomena.

This paper proposes a more accurate propagation path model in the NLOS case by analyzing the experimental results of waves reaching a receiving antenna. Propagation tests have been performed between two vehicles in communication at a fixed position on a road. Height patterns of the received power are obtained by varying a height of the receiving antenna. At first, we investigate waves passing through the space under the blocking vehicle. From this, we find out major waves arriving at the receiving antenna. In the next step of our investigation, we consider waves propagating over the blocking vehicle. The model that includes waves propagating under and over the blocking vehicle is capable of representing accurate propagation characteristics, providing an excellent means of designing cell length for the IVC at 60GHz.

2. Experimental setup

Figure 1 shows a photograph of a propagation experiment. The experiment is conducted in a smooth road, which is paved with asphalt. A transmitter (Tx) [2] is mounted on the back of a vehicle that is shown in the left side of Fig. 1. A receiver (Rx) [2] is set on an elevation tower in front of a vehicle shown in the right side of Fig. 1. The elevation tower can move the receiver in the upward and downward direction. Figure 2 illustrates experimental parameters in the propagation experiment. A height of the receiving antenna (h_r) is changed from 0.36m to 1.88m. A height of the transmitting antenna (h_t) is set to be 1.0m. Both antennas of the receiver and transmitter are standard pyramidal horn antennas whose peak gains are 23dBi at 59.1GHz. A vertical polarized

wave of 10dBm is radiated. A blocking vehicle is set on a center between the transmitting and receiving antennas. Figure 3 shows a photograph of the blocking vehicle. A commercial sedan is used as a blocking vehicle. Structural parameters of the blocking vehicle are shown in Fig. 4.

3. Calculation model

Figure 5 shows the propagation path model. The model consists of four waves propagating through the space under the blocking vehicle and five waves over the vehicle. The wave reflected by the road () is calculated by using a reflection coefficient that is obtained from the complex refractive index of asphalt ($n=2.0-j0.05$) [4]. The diffracted waves (-) is calculated by the Uniform Theory of Diffraction (UTD) [3]. The calculation model of the blocking vehicle is constructed by metal plates and six right-angle wedges, where the diffraction occurs, for simplicity.

4. Propagation characteristics

Figure 6 shows a measured height pattern of the received power. A series of periodic reductions of the received power indicates that a number of waves arrive at the receiving antenna. At the first step of our investigation, we consider the waves passing under the blocking vehicle shown in Fig. 5(a). The calculated received powers of the each waves (-) are shown in Fig. 6. From the figure, A different wave shows the strongest intensity among the waves (-) as the height of the receiving antenna increases. The double-diffracted wave () is much smaller than any other wave. From this, the three significant waves (-) are taken into consideration. Figure 7 shows a received power calculated by the 3-ray model. Although the calculated result gives substantially good agreement with the measured one, there is no periodic reduction in the result of the 3-ray model. To provide a more accurate model, the waves propagating over the blocking vehicle (-), illustrated in Fig. 5(b), are considered. Figure 8 shows the received power calculated by 8-ray model. As shown from the figure, the calculated result is in good accord with measured one, representing periodic null characteristics.

5. Conclusion

We have shown an accurate propagation path model in the NLOS case by a blocking vehicle. The propagation path model, which takes account of the three major waves under the blocking vehicle, enables us to estimate a received power approximately. Furthermore, we consider waves propagating over the blocking vehicle. The propagation path model that includes waves over the blocking vehicle is capable of representing more accurate propagation characteristics.

This study was made as a part of the Joint-research, by the Millimeter Wave Propagation Study Group, a subsection of the Inter-vehicle Communication Joint-research Group, which is also a section of ITS Joint-research Group at YRP.

References

- [1] Y. Karasawa, "Multipath Fading due to Road Surface Reflection and Fading Reduction by means of Space Diversity in ITS Vehicle-to-Vehicle Communications at 60GHz", *IEICE Trans. Commun.*, vol. J83-B, no.4, pp.518-524, Apr. 2000.
- [2] A. Kato, K. Sato, M. Fujise, "Propagation Characteristics at 60GHz on the Road for ITS Inter-Vehicle Communications", *IEICE Technical Report, ITS-99-101*, Feb. 2000.
- [3] A. Yamamoto, K.Ogawa, A. Inui, K. Nagao, T. Horimatsu, A. Kato, M. Fujise, "Propagation Models for ITS Inter-Vehicle Communications at 60GHz", *IEICE Technical Report, A-P2000-208*, Mar. 2001.
- [4] K. Sato, K. Yang, M. Fujise, "Reflection Characteristics of Asphalt Surfaces in Millimeter-Wave Band", *Communications Society Conference of IEICE, B-1-10*, Sep. 1998.



Fig. 1 Photograph of a propagation experiment

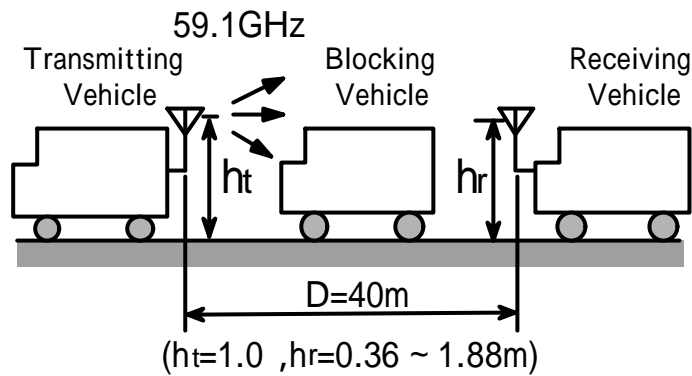

Fig. 2 Experimental parameters



Fig. 3 Photograph of a blocking vehicle

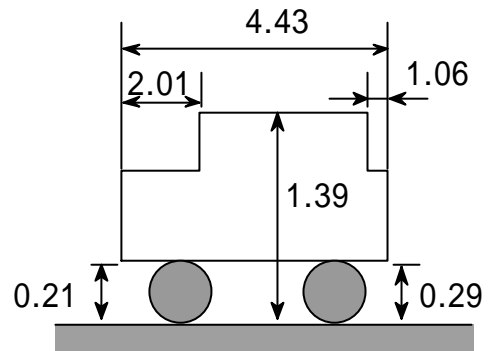
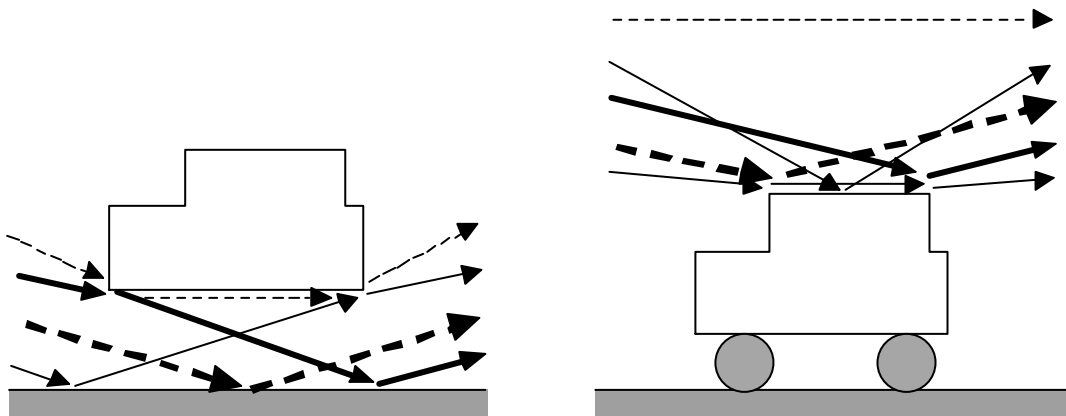

Fig. 4 Structural parameters of a blocking vehicle



(a) Waves under a blocking vehicle

(b) Waves over a blocking vehicle

Fig. 5 Waves arriving at a receiving antenna

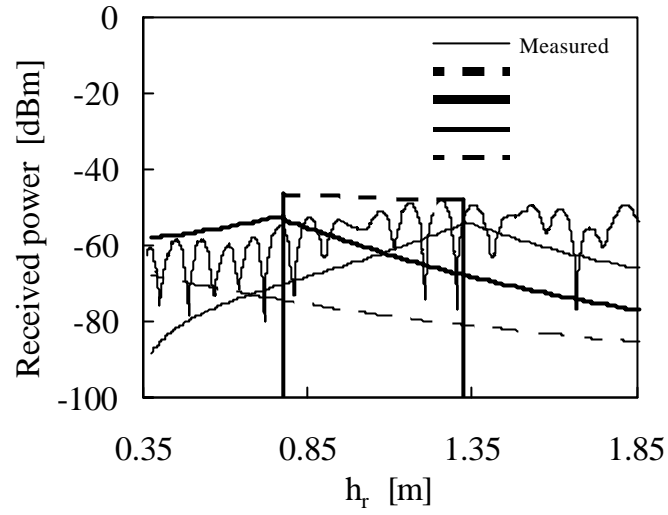

Fig. 6 Measured received power and calculated waves arriving at a receiving antenna

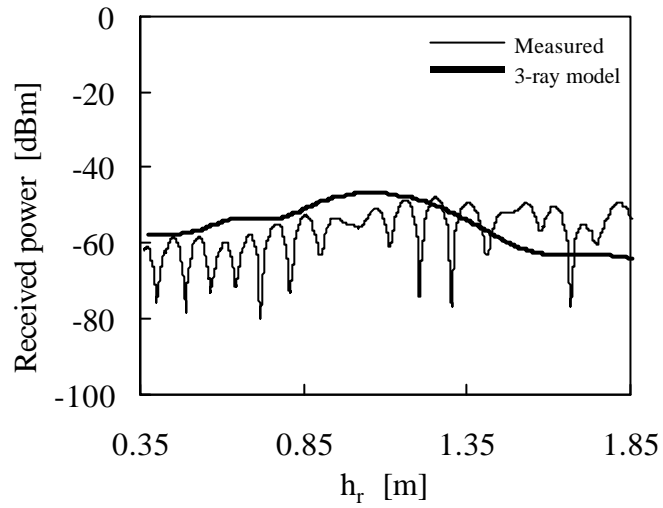

Fig. 7 Received power calculated by the 3-ray model

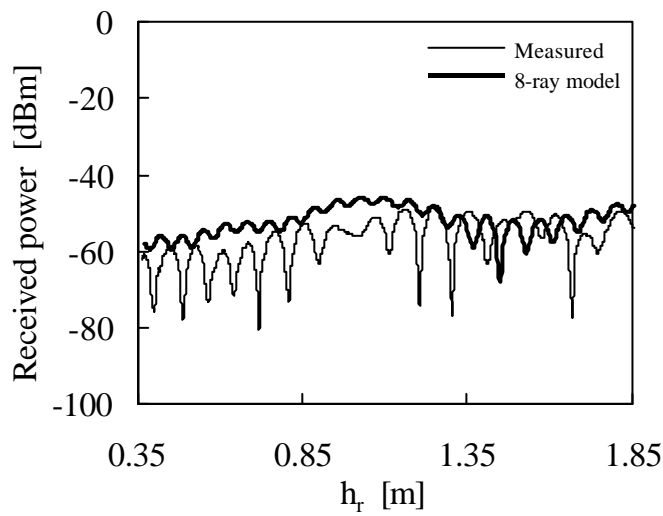

Fig. 8 Received power calculated by the 8-ray model