

A Simple Way to Design Sensor-web Model By Integrating Social Network Services

Binbin He† Masayuki Iwai‡ Kaoru Sezaki‡

1. Abstract

With the development of Wireless Sensor Networks (WSNs), the management of WSNs becomes one of important issues. Recently, researchers are inclined to use Sensor-web Model to obtain sensory data from sensor nodes, display sensory data within web site and control sensor nodes from web. It is really an innovative way to connect WSNs to Internet, but designing Sensor-web Model is a tough work. Because we need to consider security of network, administrators management, local sensory data share and so on. Actually, we can program these functions by ourselves but it will cost more labor and time. Therefore, we proposed a simple way to design Sensor-web model by integrating Social Network Services. According to our proposed method, it not only realizes the basic functions like masking complexity of WSN but also provides an easy-understand way for WSN including flexible administrators' management, security of network and data sharing from local to global domain. Moreover, by using this method can save more labor cost and time than normal design pattern.

Keyword: Wireless Sensor Network, Sensor-web Model, Network Management, Social Network Services, OAUTH.

2. Introduction

Recently, Wireless Sensor Networks (WSNs) attracted more attention due to its low cost and mobility which can be used to health, habit, factory, and environment monitor or home automation and so on. Based on the latent of WSNs, more and more products are also developed for experiments such as SunSPOT and Mica. The paper [1] introduces how to use SunSPOT to monitor greenhouse.

In many of applications, we need to retrieve, manage sensory data and control sensor nodes. Therefore, how to manage WSNs becomes one of important issues. Now, more and more researchers are inclined to use Sensor-web model to manage WSNs like SenseWeb [2], Web-of-Thing [3] and S-Sensors [4]. It is a great step to connect WSNs to Internet. Normal persons can check sensory data from web site and administrators also can check the status of WSNs, control WSNs from web site in any place where has Internet.

On the other side, designing a appropriate Sensor-web model is a tough work for example we need to consider about security of network while controlling WSN from web otherwise our network will be invaded by other invalid users, it is needed to consider about flexible administrators management while WSN's

scale become more and more huger, add or delete administrators become a common occurrence. Furthermore, we also hope to show our devices to each other to do globally experiments while we do not have enough devices. Normally, designing and creating these functions will be a labor and time cost work. In order to overcome these problems, we proposed a simple way to design Sensor-web Model by integrating existed applications which are Social Network Services. The merits of proposed method are listed as follows:

- A) They are free applications which means we do not need to pay extra money.
- B) They provide RESTful API which also frequently used in Sensor-web Model. This means the integration will be fast.
- C) We can share local sensory data to global domain. Such as put nuclear detect WSN around every weather station, and send nuclear radiation to SNS, everyone who uses SNS could see these data immediately.
- D) We can realize flexible administrators' management such as add or delete administrators just by adding them as friends or deleting them from friends list. Moreover, using this function, we can also share our devices globally easily.
- E) Higher security. Because in every SNS, they all use OAUTH instead of basic authentication which has higher security level than basic authentication.

The remainder of this paper is organized as follows: The detail of proposed method will be described in section 3. Section 4 concludes the paper and introduces some future works.

3. The description of our proposed method

In the future, WSNs not only just connect to web site,

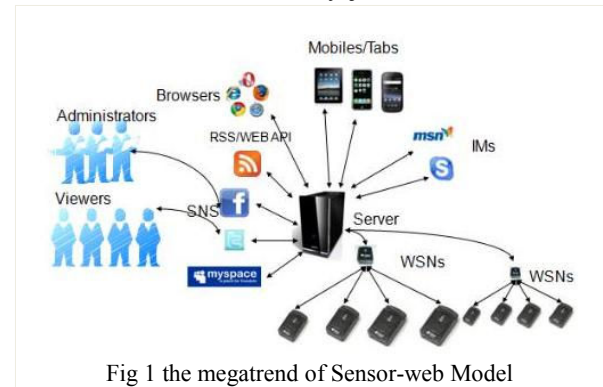

connecting to SNS will become a megatrend just like we depicted in fig.1. Administrators can use SNS to realize any function for WSNs instead of web site. Based on the fig 1, we integrated SNS to Sensor-web model and divide the whole architecture into three layers shown in fig 2. We define clearly

†Institute of Industrial Science, the University of Tokyo.

‡Institute of Industrial Science, Center for Spatial Information Science, the University of Tokyo.

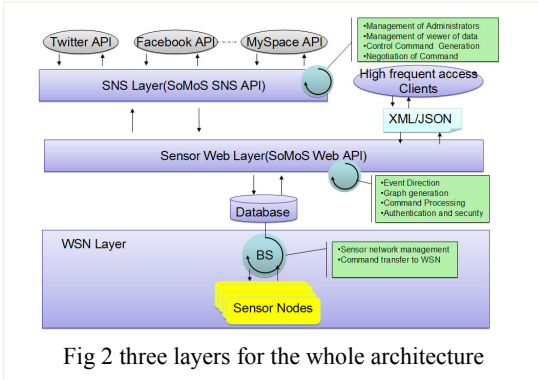

Fig 2 three layers for the whole architecture

three layers are WSN layer, Sensor-web layer, and SNS layer. WSN layer and Sensor-web layer play the same role compare to other sensor-web models. The different is that we build SNS layer above sensor-web layer. By adding this novel SNS layer, we can realize four mainly functions:

(1) Control WSN from SNS

Take Twitter as an example, we can send command as follows:

```

SezakiLabBot Sezaki Lab Bot
{"sbj":"ans_info","name":"sezakilab1","id":"0014.4F01.0000.5B91"
mp":"13.25","light":460,"battery":1,"rssi":40} with time 23:40:51
23 seconds ago

SezakiLabBot Sezaki Lab Bot
@SezakiLabBot
{"sbj":"get_info","name":"sezakilab1","type":"all","test":95}
    
```

Which means to obtain all information from sensor node named as "sezakilab1" within WSN named as "SezakiLabBot".

```

SezakiLabBot Sezaki Lab Bot
{"sbj":"set_succeeded","name":"sezakilab1","cyclotime":30,"outputp
ower":-3} from: @SezakiLabBot with time: 00:07:58
14 seconds ago

SezakiLabBot Sezaki Lab Bot
@SezakiLabBot
{"sbj":"set_naram","name":"sezakilab1","cyclotime":30,"test":80}
    
```

Which means to modify sensing rate to 30 seconds for sensor node named as "sezakilab1" within WSN named as "SezakiLabBot".

(2)Flexible administrators' management

Just we mentioned before, with the increasing of WSN's scale, two problems happened in WSN like Fig 3 and Fig 4.

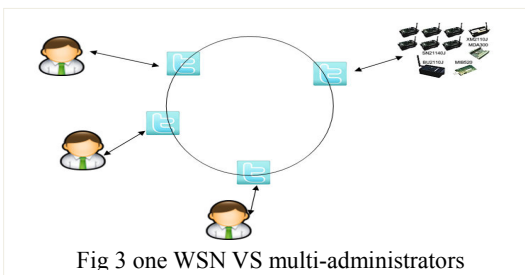

Fig 3 one WSN VS multi-administrators

In order to solve this problem, we take Twitter as example, in Twitter, they have functions like Following and Followers. If one user wants to become administrator, we just need to follow him/her. Certainly, we can un-follow him/her to delete user from administrator list. (Fig 5)

(3)Share device globally

Sometimes, we hope to do globally experiments, unfortunately we do not have enough fiscal budgets to buy devices or go worldwide to deploy our WSN. By using our proposed method,

into we can easily cooperate with each other without any extra cost (Fig.6).

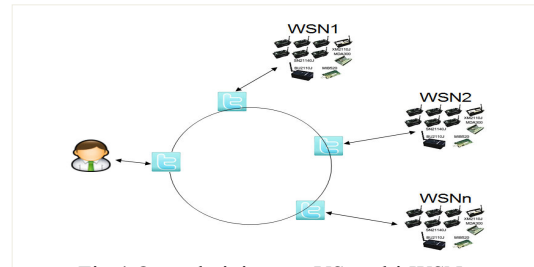

Fig 4 One administrator VS multi-WSNs

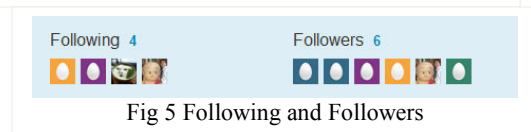

Fig 5 Following and Followers

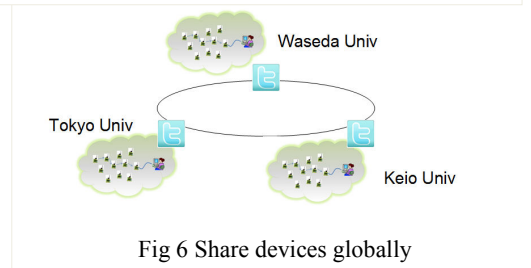

Fig 6 Share devices globally

(4)Security

In SNS, every application use OAUTH which has higher security level than normal system.

Here we list the contrast between two patterns

| Pattern | Security | Data share | Administrator management | Device share |
|------------------|----------|------------|--------------------------|--------------|
| Normal Pattern | ○ | ○ | ○ | ○ |
| Proposed Pattern | × | × | × | × |

○ means when we design sensor-web model, we need to consider about these factors.

4. Conclusion and Future work

In this paper, we have developed a simple way to design Sensor-web Model by integrating Social Network Services which make a great reduction of labor and time cost than normal Sensor-web design pattern. As future work, we will do large scale test for our proposed method.

5. References

[1]J.S, M.G;Web based distant monitoring and control for greenhouse systems using SunSPOT modules. Intelligent Systems and Informatics, 2009.SISY09. 25-26 Sept 2009, pp165-169.
 [2]Kansal, A., Nath, S., Liu, J., Zhao, F.: SenseWeb: an infrastructure for shared sensing. IEEE Multimedia 14(4), 8-13 (2007)
 [3]GD, T.V, P.T and L.O, "Towards physical mashups in the Web of Things" in INSS 2009, June 2009, pp.1.
 [4]B.M and K.A. "S-Sensors: Integrating Physical world inputs with social networks using wireless sensor networks", in Intelligent Sensors, Sensor Networks and Information Processing(ISSNIP), 2009, pp.213.