

Substrate Integrated Waveguide Antenna Arrays for High-Performance 60 GHz Radar and Radio Systems

Ajay Babu Guntupalli and Ke Wu

Poly-Grames Research Center, Electrical Engineering department
Ecole Polytechnique (University of Montreal)
Montreal, Canada, H3T 1J4.

Abstract- This article presents and discusses some of the recent developments on 60 GHz antenna arrays in substrate integrated waveguide (SIW) technology. They include planar linearly polarized (LP) antenna, three dimensional (3-D) high gain LP antenna, multi-layer single circularly polarized (CP) antenna, and 3-D dual circularly polarized antenna (DCP) over 60 GHz frequency range. Single LP antenna is realized by loading anti-podal linearly tapered slot antenna (AL TSA) with dielectric rod antenna. The dielectric rod antenna is used as a radiating element to construct 4×4 antenna array. Single right-hand circularly polarized (RHCP) antenna is constructed by using SIW as feeding network and CP patch as radiating element. 2×2 RHCP array makes use of an aperture coupling method to excite each antenna element. In the final prototype, DCP antenna is constructed by using multi-layer E-plane coupler and rod radiating element. All the proposed antenna arrays are experimentally validated and compared with the simulated counterparts.

I. INTRODUCTION

Millimeter-wave wave (or mm-wave) antenna arrays with single linear and dual circular polarization characteristics are widely being used for numerous applications including wireless data communication, radar sensors, passive imaging, energy harvesting, and cognitive radio systems. The simplified block diagram of a radar transceiver using single LP antenna and CP antenna is shown in Fig. 1a, b. Radar with CP antenna can detect chest and heart displacement irrespective of the patient position [1]-[3]. The sensor can always detect amplitude variations even polarization of patient is not matched with the transmitting antenna. Another application of CP antenna in energy harvesting techniques, where the rectified output voltage would become constant when compared with the scenario of an LP antenna. To satisfy front-end requirements of these systems, two different techniques have been proposed to obtain circular polarization at mm-wave frequency.

Among different types of feeding mechanism, waveguide is an excellent candidate to implement low-loss feeding networks and high gain antenna arrays over mm-wave frequency range [4]-[5]. Those waveguide-based antennas have been exhibiting excellent radiation characteristics, but they are not easy to

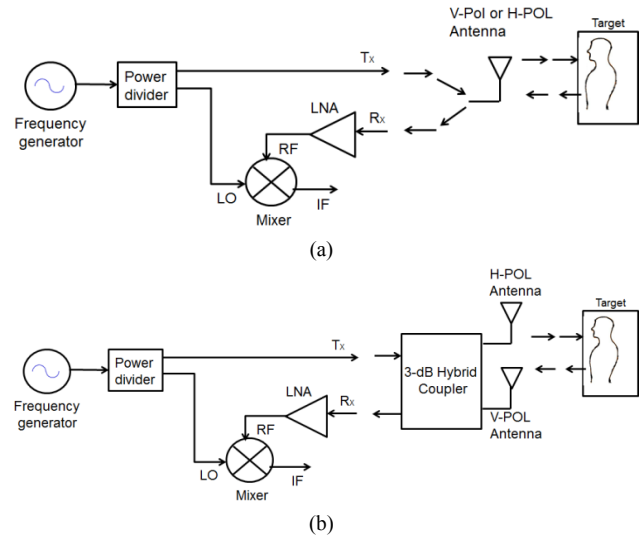

Figure 1. General simplified block diagram of a radar sensor using dual circular polarization antenna to detect human heart beat and respiration.

integrate with active components on a single substrate. The microstrip-fed patch array proposed in [6] is easy to characterize and to integrate on a single substrate. However, antenna efficiency is lower than 50% at the 60 GHz frequency range. Low temperature co-fired ceramic (LTCC) technology was used to implement high efficiency antenna arrays in [7]-[11]. The antenna efficiency was shown better than 90%, but the fabrication cost would be high.

At mm-wave frequency, SIW (substrate integrated waveguide) is an outstanding candidate to implement low loss and low cost feeding mechanism. SIW-fed antenna is able to yield high radiation efficiency and broadband impedance behavior. At 60 GHz, SIW-fed antenna arrays with linear polarization were proposed in [12]-[16] and circular polarization in [17] and [18]. In this work, frequency range from 57 GHz to 64 GHz is chosen to design a number of high performance antenna arrays with linear and dual circular polarizations. The proposed CP antenna can be integrated with the front end of the systems proposed in [19] and [20].

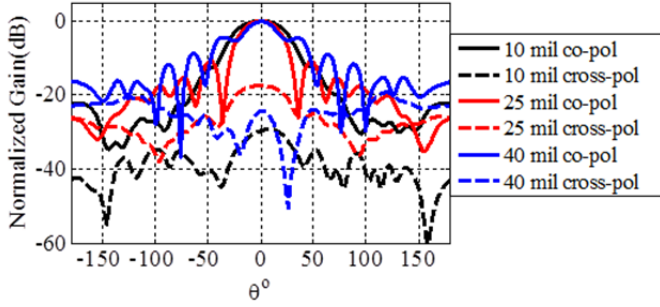

Figure. 2. E-plane co-pol and cross-pol radiation patterns as a function of substrate thickness.

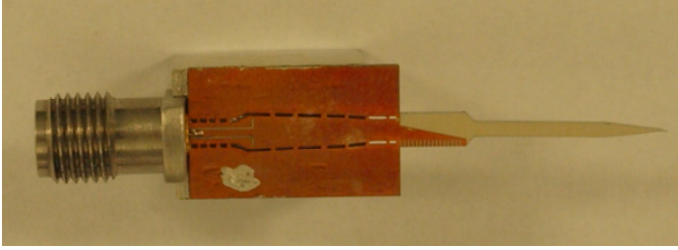

Figure. 3. ALTSA is loaded by a tapered dielectric rod.

II. PLANAR DIELECTRIC ROD ANTENNA

Among the substrate integrate circuits (SICs) family, substrate integrated image guide (SIIG) have been used in [21] and integrated non-radiative dielectric waveguide (SINRD) have been used in [22] to feed a dielectric rod antenna. These two families of SICs require an additional transition to interface with the other parts of circuit. The third and well-known family member of SICs, is SIW that has also been used for the design of feeding networks, e.g., in [23] and to develop high-gain dielectric rod antenna arrays. In this work, ALTSA antenna is loaded with planar dielectric rod antenna to amplify the gain of the combination [18].

Antenna cross-pol and side-lobe level as a function of the substrate thickness is given in Fig. 2. As the substrate thickness increases, cross pol level and side lobe levels also increase. As the thickness increases, fields are loosely bounded within the dielectric substrate hence the polarization purity is also reduced. For 10 mil thickness, the cross-pol value is less than -29.35 dB and the worst side lobe value is about -26 dB. Experimental antenna prototype is shown in Fig. 3. To obtain a better matching condition, a grounded coplanar waveguide (GCPW) to SIW transition is designed and used to measure the cascaded section of ALTSA and rod antenna. The transition behavior is similar to the operating principle of a dipole antenna. Input impedance and radiation pattern are measured by using the V-connector. Thus, the final architecture of the proposed antenna is a series combination of GCPW transition, linearly tapered slot antenna and dielectric rod antenna.

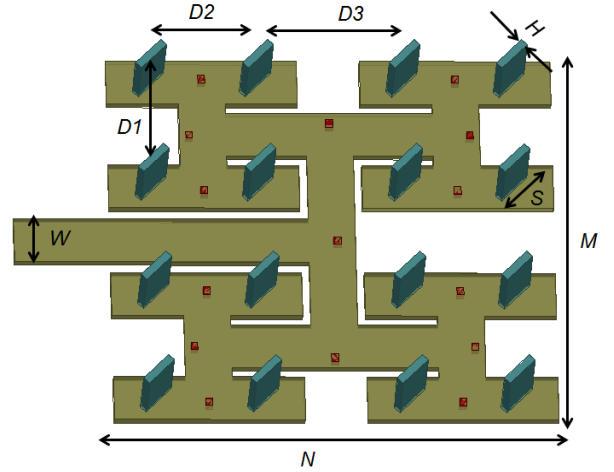
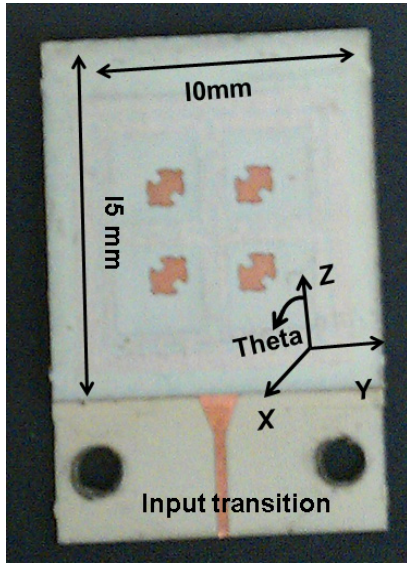

Figure. 4. Three dimensional view of the feed network where input port on the XY -plane and 16 output ports are located on the vertically placed SIW lines.

III. HIGH GAIN ANTENNA ARRAY

In this work, a 45° LP planar array utilizing 16 radiating elements is proposed for the 60 GHz frequency systems. Array occupies the total volume of $2.8\lambda \times 3.2\lambda \times 5.1\lambda$ with an average peak gain of 17.5 dBi over 8.3% of pattern bandwidth. Dielectric rod antenna gain is a function of rod length. SIW-fed rod antenna discussed in the previous section is selected as a radiating element to implement high efficiency antenna array. The feed network of 4×4 rod antenna array is shown in Fig. 4. The planar power divider and bend used at each intersection are optimized to have better impedance match over all the bandwidth. Sixteen antenna elements and feed network are integrated together to realize the final prototype. Antenna performance characteristics are measured by using a Southwest microwave end-launch connector. Simulated and measured input impedances (with $|S_{11}| < -8$ dB) are matched over a bandwidth from 57 GHz to 64 GHz.

Far-field radiation pattern is measured in an anechoic chamber with 45° polarization set at transmitting horn antenna. Antenna gain is measured as 16.5 dB, 17 dB and 17.5 dB at 59 GHz, 60 GHz and 62 GHz frequency. Side lobe levels in both E-plane and H-plane are lower than -10 dB and cross-polarization is lower than -18 dB from the maximum gain value of 18 dBi. The thickness of 10 mil is chosen to improve the cross-polarization level of rod antenna. Nevertheless, the mechanical strength is reduced and also the rod antenna end-points are slightly misaligned along Z-axis of orientation.



(a)

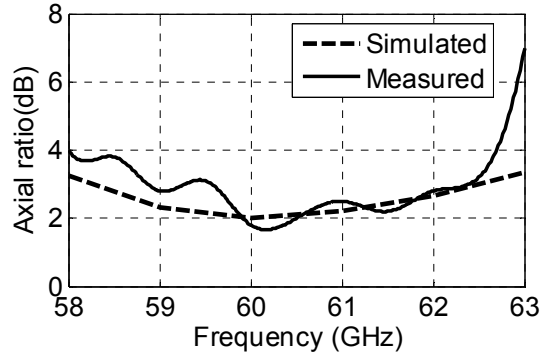

(b)

Figure 5. Fabricated prototype of the Single RHCP array.

IV. SINGLE CP ANTENNA ARRAY

A parallel type of feeding topology is chosen to remove the beam squint effect, which naturally occurs in a series feeding topology. An SIW power divider and its physical parameters obtained through modeling are given in Fig. 3a. Magnitude of the input reflection coefficient is less than -15 dB from 57 GHz to 64 GHz. The power is divided equally among the four output ports.

The final array construction in 3 layers is shown in Fig. 5a. The SIW feed network is integrated on layer 1. The slots provide required excitation coefficients for an array. Layer 2 works as an air gap between feeding layer 1 and antenna layer 3. Mutual coupling between antenna elements is reduced by placing an array of vias in a rectangular cavity under each antenna element. Layer 3 is a radiating layer, where the circularly polarized patch antennas are integrated on an ultrathin substrate. The feed network printed on a high dielectric permittivity allows a freedom to choose the spacing between antenna elements. The optimum spacing between antennas sums up the individual element patterns to contribute

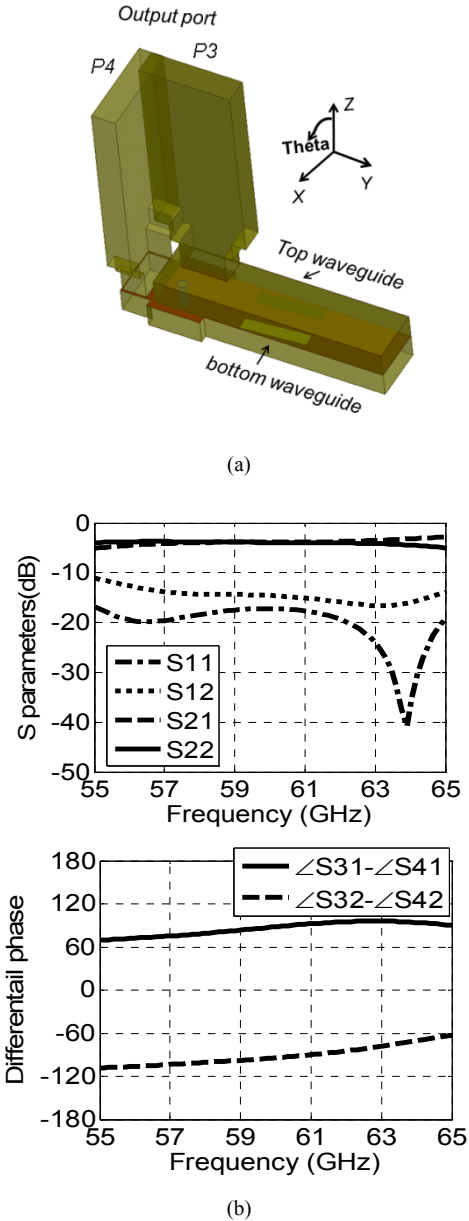

Figure 6. CP antenna feed network (a) architecture (b) amplitude and phase performance.

to the maximum total gain. Simulated and measured axial ratios as a function of frequency are compared in Fig. 5b. Measured AR value is less than 3.5 dB from 58 GHz to 62 GHz.

V. DUAL CIRCULARLY POLARIZED ANTENNA

In this work, E-plane coupler is used as a feeding topology to supply equal amplitude for two LP components with 90° phase shift. The proposed DCP antenna is working in left-hand circularly polarized (LHCP) mode and right-hand circularly polarized wave (RHCP) mode for port 1 and port 2, respectively. Four port feeding network shown in Fig. 6a is used to obtain a DCP radiation at the 60 GHz frequency range. Input ports $P1, P2$ are located on the horizontal plane and output ports $P3, P4$ are located on the vertical plane. Four SIW

transmission lines are arranged in a three dimensional (3-D) configuration, where vertical and horizontal waveguides are connected through an SIW vertical interconnect. Coupler is used to feed with equal power division between $P3$ and $P4$. A differential phase shift of $+90^\circ$ is realized for excitation at $P1$ and -90° for excitation at $P2$. Hence, the condition for CP operation is satisfied in the proposed feed network. The output port lengths are unequal for the two orthogonally polarized array ports. To retain 90° phase shift, an unequal width and unequal length phase shifter is integrated between output ports of the coupler. As shown in Fig. 6a, the antenna feed network is designed in the SIW technology and later used to feed an SIW fed rod antenna. Output ports $P3$ and $P4$ are loaded with two SIW fed dielectric rod antennas to realize the final prototype. Simulated amplitude and phase performance as a function of frequency is plotted in Fig. 6b. All interconnects are matched from input to output ports, so all the field is coupled to the output ports. For port $P1$, a differential phase shift between output ports varies from 77° to 91° and amplitude coefficient varies between -3.7 dB and -4.1 dB over the frequency range from 57 GHz to 65 GHz. Measured half-power beam width (HPBW) in both the pattern cuts is 39° with side lobe levels are lower than -10 dB for both input ports $P1$ and $P2$.

VI. CONCLUSION

In this work, two linearly polarized antennas and two circularly polarized antennas have been proposed and experimentally validated in SIW technology. Feed network and antenna are designed to share the SIW transmission line. Antenna efficiency greater than 70% is obtained for all the proposed techniques. The proposed antennas can be used for radio and radar front-ends that require single linear or single circular or even dual circular polarization at mm-wave frequency.

ACKNOWLEDGMENT

The authors wish to thank T. Antonescu for his help in the fabrication of the prototypes and M. Thibault for his help in measuring the radiation pattern in our anechoic chamber.

REFERENCES

- [1] T.Y.J Kao, Y. Yan, T.M. Shen, A.Y.K Chen, and J.Lin, "Design and Analysis of a 60-GHz CMOS Doppler Micro-Radar System-in-Package for Vital-Sign and Vibration Detection," *IEEE Transactions on Microwave Theory and Techniques*, vol.61, no.4, pp.1649,1659, April 2013
- [2] T.M. Shen, T.J. Kao, T.Y. Huang, J. Tu, J. Lin, R.B. Wu, "Antenna Design of 60-GHz Micro-Radar System-In-Package for Noncontact Vital Sign Detection," *IEEE Antennas and Wireless Propagation Letters*, vol.11, pp.1702-1705, 2012.
- [3] K.K.M. Chan, A.E. Tan, and K. Rambabu, "Circularly Polarized Ultra-Wideband Radar System for Vital Signs Monitoring," *IEEE Transactions on Microwave Theory and Techniques*, vol.61, no.5, pp.2069-2075, May 2013.
- [4] T. Tomura, Y. Miura, Z. Miao; J. Hirokawa, and M. Ando, "A 45° Linearly Polarized Hollow-Waveguide Corporate-Feed Slot Array Antenna in the 60-GHz Band," *IEEE Transactions on Antennas and Propagation*, vol.60, no.8, pp.3640-3646, Aug. 2012.
- [5] D. Kim; M. Zhang; J. Hirokawa, and M. Ando, "Design of dual-polarization waveguide slot array antenna using diffusion bonding of laminated thin plates for the 60 GHz-band," *2012 IEEE Antennas and Propagation Society International Symposium (APSURSI)*, , vol., no., pp.1-2, 8-14 July 2012.
- [6] N. Chahat, M. Zhadobov, S.A. Muhammad, L. Le Coq, R. Sauleau., "60-GHz Textile Antenna Array for Body-Centric Communications," *IEEE Transactions on Antennas and Propagation*, vol.61, no.4, pp.1816-1824, April 2013.
- [7] S-B Yeap, X. Qing, M. Sun, and Z. N. Chen, "140-GHz 2x2 SIW horn array on LTCC," *IEEE Asia-Pacific Conference on Antennas and Propagation (APCAP)*, 2012, vol., pp.279-280, 27-29 Aug. 2012.
- [8] M. Sun, Y.X. Guo, M.F. Karim, and L.C. Ong, "Linearly polarized and circularly polarized Arrays in LTCC Technology for 60GHz Radios," *2010 IEEE Antennas and Propagation Society International Symposium (APSURSI)*, pp.1-4, 11-17 July 2010.
- [9] C. R. Liu, Y. X. Guo, X. Y. Bao and S. Q. Xiao "60-GHz LTCC integrated circularly polarized helical antenna array," *IEEE Trans. Antennas Propag.*, vol. 60, no. 3, pp.1329-1335 2012.
- [10] Y. Li, Z. N. Chen, X. Qing, Z. Zhang, J. Xu, and Z. Feng, "axial ratio bandwidth enhancement of 60-GHz substrate integrated waveguide-Fed circularly polarized LTCC antenna Array," *IEEE Trans. Antennas Propag.*, vol.60, no.10, pp.4619-4626, Oct. 2012.
- [11] L. Wang, Y.-X. Guo, and W.X. Sheng, "wideband high-gain 60-GHz LTCC L-Probe patch antenna array with a soft surface," *IEEE Trans. Antennas Propag.*, vol.61, no.4, pp.1802-1809, April 2013.
- [12] S. Mei, Q. Xianming and C. Zhi Ning, "60-GHz antipodal Fermi antenna on PCB," *Proceedings of the 5th European Conference on Antennas and Propagation (EUCAP)*, vol., no., pp.3109-3112, 11-15 April 2011.
- [13] X. P. Chen, K. Wu, L. Han, and F. H. , "Low-cost high gain planar antenna array for 60-GHz band applications," *IEEE Trans. Antennas Propag.*, vol. 58, no. 6, pp. 2126–2129, Jun. 2010.
- [14] M. Ohira, A. Miura and M. Ueba "60-GHz wideband substrate-integrated-waveguide slot array using closely spaced elements for planar multiselector antenna", *IEEE Trans. Antennas Propag.*, vol. 58, no. 3, pp.993-998 2009.
- [15] Y. Zhang, Z.N. Chen, X. Qing, and W. Hong, "Wideband Millimeter-Wave Substrate Integrated Waveguide Slotted Narrow-Wall Fed Cavity Antennas," *IEEE Transactions on Antennas and Propagation*, vol.59, no.5, pp.1488-1496, May 2011.
- [16] O. Kramer, T. Djerafi, and K. Wu, "Very small footprint 60 GHz stacked Yagi antenna array," *IEEE Trans. Antennas Propag.*, vol. 59, no. 9, pp. 3204–3210, Sep. 2011.
- [17] Q. H. Lai, C. Fumeaux, W. Hong, and R. Vahldieck, "60 GHz aperture-coupled dielectric resonator antennas fed by a half-mode substrate integrated waveguide," *IEEE Trans. Antennas Propag.*, vol. 58, no. 6, pp. 1856–1864, Jun. 2010.
- [18] A.B. Guntupalli, and K. Wu, "Polarization-Agile millimeter wave antenna arrays" *Proceedings of Asia-Pacific Microwave Conference, APMC 2012*, Kaohsiung, Taiwan, pp. 148-150, Dec. 4-7, 2012.
- [19] N. Athanasopoulos, D. Makris, and K.Voudouris, "Millimeter-wave passive front-end based on Substrate Integrated Waveguide technology," *2012 Antennas and Propagation Conference (LAPC)*, Loughborough, vol., no., pp.1-5, 12-13 Nov. 2012.
- [20] L. Chioukh, H. Boutayeb, K. Wu, and D. Deslandes, "Monitoring vital signs using remote harmonic radar concept," *European Radar Conference (EuRAD)*, 2011, vol., no., pp.381-384, 12-14 Oct. 2011.
- [21] A. Patrovsky and K. Wu, "94-GHz planar dielectric rod antenna with substrate integrated image guide (SIIG) feeding," *IEEE Antennas Wireless Propag. Lett.*, vol. 5, pp. 435–437, 2006.
- [22] N. Ghassemi and K. Wu, "Planar Dielectric Rod Antenna for Gigabyte Chip-to-Chip Communication," *IEEE Transactions on Antennas and Propagation*, vol.60, no.10, pp.4924-4928, Oct. 2012.
- [23] R. Kazemi, A.E Fathy and R.A Sadeghzadeh, "Dielectric Rod Antenna Array with Substrate Integrated Waveguide Planar Feed Network for Wideband Applications," *IEEE Transactions on Antennas and Propagation*, vol.60, no.3, pp.1312-1319, March 2012.