

Research on Circularly Polarized Small Disk Coupled Square Ring Microstrip Antenna for GPS Application

PENG Cheng, YU Tongbin, LI Hongbin, CAO Wenquan

Abstract—A circularly polarized (CP) small Disk coupled square ring microstrip antenna is presented in this paper. The CP radiation of the presented antenna is achieved by using two disks under the square ring fed by two probes with 90-degree phase shift. The resonant frequency of the antenna is at 1.575GHz, Which is lowered by about 23.4% as compared to that of the normal patch antenna. The axial ratio (AR) of the antenna is lower than 3dB and the maximum gain is more than 3dB at the resonant frequency, and the isolation between the two disks is lower than -18dB during the operating band. The measured results of the fabricated antenna agree well with the simulated results.

Index Terms—Circularly polarized, small Disk coupled, Square ring, microstrip antenna

I. INTRODUCTION

MICROSTRIP antenna has been widely used in the cellular communication systems. As the integration of the communication equipment develops, the technique of miniaturized micro-strip antenna has been paid more attention.

The square-ring microstrip antenna is usually smaller than the normal patch antenna (because the current path has been lengthened) [1], which has been paid more and more attention these years. But, as the size of the antenna reduces, the input impedance grows fast. So it is necessary that the inside diameter W_1 of the square ring is less than 40% of the outside diameter W_2 for the probe-feed method to achieve 50Ω input impedance match[2], and this becomes a problem for the miniaturized micro-strip antenna. Reference [3] added a Cross strip which is fed by probes to achieve 50Ω input impedance match, and the center frequency was lowered by about 22% with the same antenna size. Reference [4] used stacking technique to get input impedance match and to enhance the bandwidth, but it would enlarge the size of the antenna. Reference [5] used the circumferential variation of current on the ring to achieve 50Ω input impedance match, but it did not give antennas for circular polarization. Reference [6] put a rectangular disk under the square-ring patch for the coupling-feed, but the size of the antenna is too big and circular polarization is hard to achieve..

This paper uses dual feed method to design a circularly polarized microstrip antenna [7], and we found that the disk coupled method can easily achieve 50Ω input impedance and reduce the size of the square ring further more.

II. ANTENNA DESIGN

The circularly polarized small disk coupled microstrip antenna uses double layer structure as showed in Fig 1. The size of the substrate and the ground plane is $L_g \times L_g$, the height of the bottom substrate is h_1 , the height of the top layer is h_2 , and both of the two layers have the relative permittivity ξ . The square ring is on the surface of the top layer, with the inner side length W_1 and the outer side length W_2 . In order to make the antenna radiate circularly polarized electromagnetic wave, we use the dual feed method [8]. The square ring is coupled with two circular disks fed by probe, and each disk has a radius r . The distance between the center of the disk and the center of the square ring side nearby is d , which is one of the key parameter for the 50Ω input impedance match.

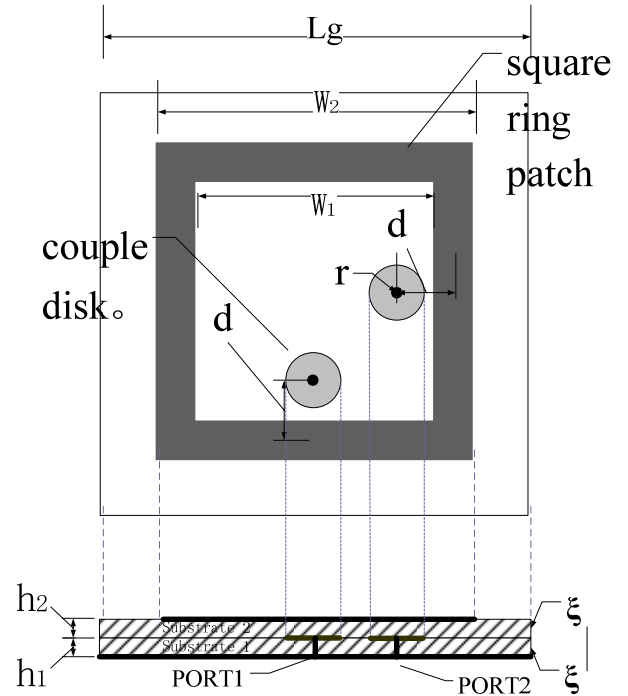

Fig. 1. The structure of the small disk coupled microstrip antenna.

The antenna has been built and simulated using ANSOFT HFSS software. By adjusting the parameter d , we could easily achieve the 50Ω input impedance when W_1 , W_2 and r (the radius of the circular disks) is assumed. In order to make the antenna operating at GPS band(the center frequency is at 1.575GHz), the antenna size is optimized as $L_g=50\text{mm}$,

$W_1=24\text{mm}$, $W_2=35\text{mm}$, $h_1=2\text{mm}$, $h_2=1\text{mm}$, $\xi=3.5$, $r=3.9$. The input impedance of the antenna changes with d , as we can see from Table I, and we can find the best position of the two disks to achieve 50Ω input impedance.

TABLE I

d/mm	Resonant frequency/GHz	-10dB bandwidth/MHz	Minimum S_{11}/dB
1	1.58	0	-2.01
2	1.58	0	-2.23
3	1.58	0	-3.76
4	1.58	0	-4.77
5	1.58	0	-8.64
6	1.58	18	-13.51
7	1.59	0	-4.60
8	1.60	0	-1.53

In Table I we find that we can get good impedance match when d is close to 6mm. When we optimized d as 5.85mm, we get the minimum S_{11} of -21.59dB and the -10dB impedance bandwidth of 20MHz.

The disk coupled method is a good solution to achieve 50Ω input impedance. But when we use dual feed method to get circular polarization antenna, the mutual coupling between the two capacitive disks becomes a problem [8]. The isolation between the two probes changes with the radius of the disks, and it is hard to get good performance of the antenna. Therefore, r is another key parameter that can both affect the isolation between the two probes and the input impedance match.

TABLE II

r/mm	Maximum S_{12}/dB	-10dB bandwidth/MHz	Minimum S_{11}/dB
0.9	-40.01	0	-0.36
1.9	-29.35	0	-1.22
2.9	-23.71	0	-5.89
3.9	-18.64	20	-21.59
4.9	-10.01	8	-10.58
5.9	-20.01	0	-5.28

From Table II we can find that when the position of the feeding probes are assumed, S_{12} changes with the size of the disk. When r increases, the absolute value of S_{12} reduces. The reason is that the mutual coupling becomes more intensive when the disks are close to each other. When the radius of the two disks is bigger than 4.9mm, the absolute value of S_{12} increases again. When r grows more than 6mm, the two disks will connect to each other. The size of the disk can also affect the 50Ω input impedance match [9]. When the radius of the two disks is set as $r=3.9\text{mm}$ the best 50Ω input impedance match is achieved, while the maximum S_{12} is -18.64dB. Since this is enough for the dual-feeding network, so we choose r as 3.9mm

III. SIMULATED AND MEASURED RESULTS

After the parameters of the antenna are chosen according to simulated results, the antenna is fabricated. The fabricated antenna and its feeding network can be seen clearly in Fig 2(a)

and Fig 2(b). The antenna use two disks fed by one willkins power divider under the ground plane.

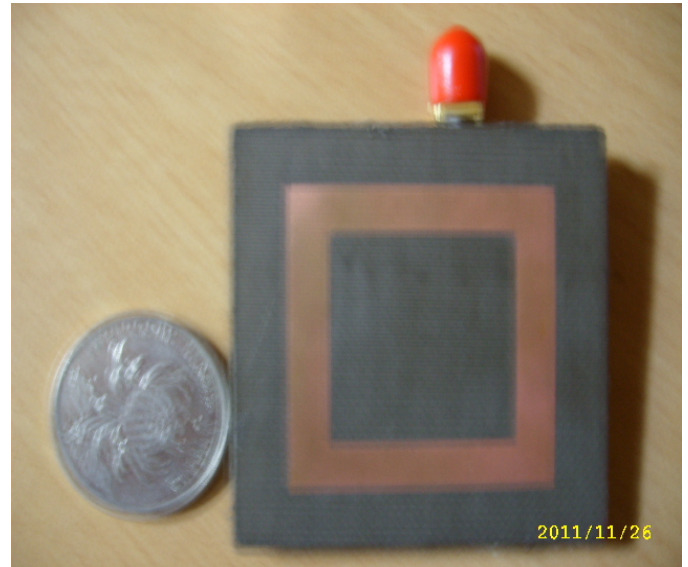

Fig 2(a) The patch



Fig 2(b)The feeding network

Fig. 2. The small disk coupled square ring microstrip antenna and its feeding network. There are two disks fed under the square ring. It is multi-layer structure

Fig.3 shows the simulated and measured plots of the gain and the axial ratio of the fabricated antenna. The measured results agree well with the simulated results. From Fig3(a) we can see that the 3dB-beam width has reached 120 degree while the maximum gain is about 3dB. The maximum gain of the fabricated antenna is lower than that of the normal patch antenna, this may be caused mainly by beam width enlarging and size reduction. We can also see that the measured result is a bit lower than the simulated result, it may be caused by the imprecise fabrication. Fig3(b) shows that the AR is lower than 3 dB when theta is from -60 degree to +60 degree.

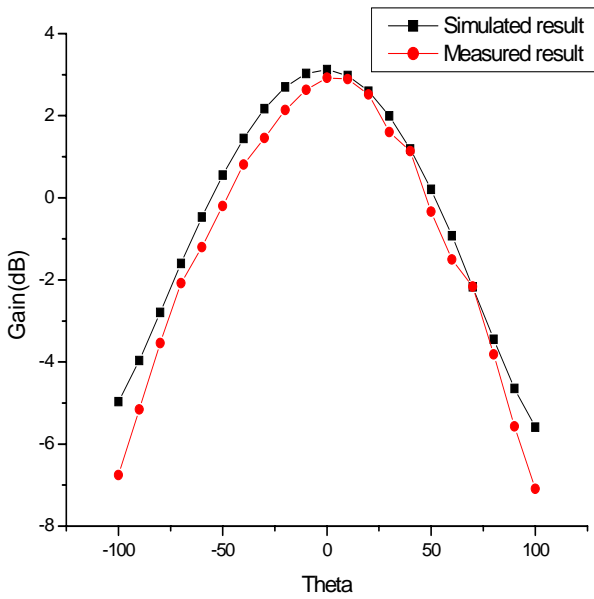

Fig 3(a) Simulated and measured gain at resonant frequency

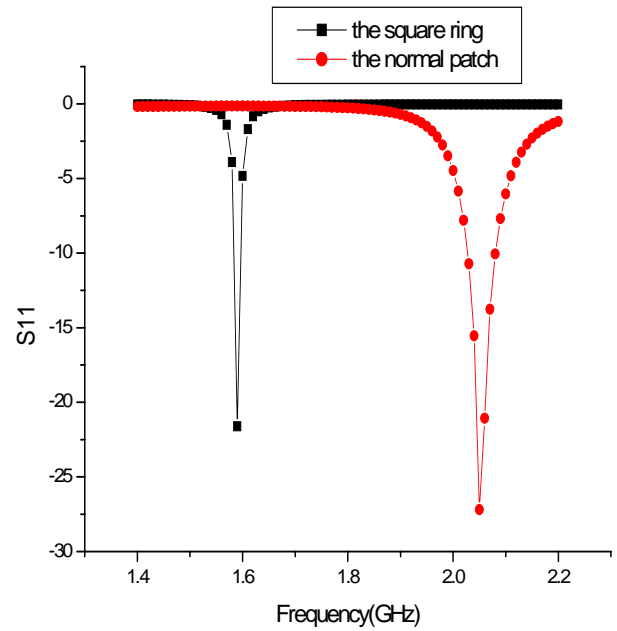

Fig 4 The reflection coefficient of the two antennas

From Fig 4 we can see that the center frequency of the small disk coupled square ring (1.575GHz) is lowered by about 23.4% as compared to that of the normal patch (2.05GHz). This means that a good antenna size reduction can be obtained. Though the -10dB bandwidth becomes narrower (from 50MHz to 20MHz), it is still enough for the GPS Applications (only need 5MHz). Working at the GPS band (the center frequency is at 1.575GHz) [10], the small disk coupled square ring microstrip antenna has a 27% size reduction compared with the normal patch antenna.

IV. CONCLUSION

A successful design of circularly polarized small disk coupled square ring microstrip antenna is presented in this paper. Compared with the normal patch antenna, the antenna gets a 27% size reduction and wider beam width. The input impedance match in the square ring microstrip antenna is achieved by using two disks fed by two probes. The mutual coupling between the two disks is analyzed in detail. The proposed antenna has been fabricated and tested, the results agree well with the simulated results.

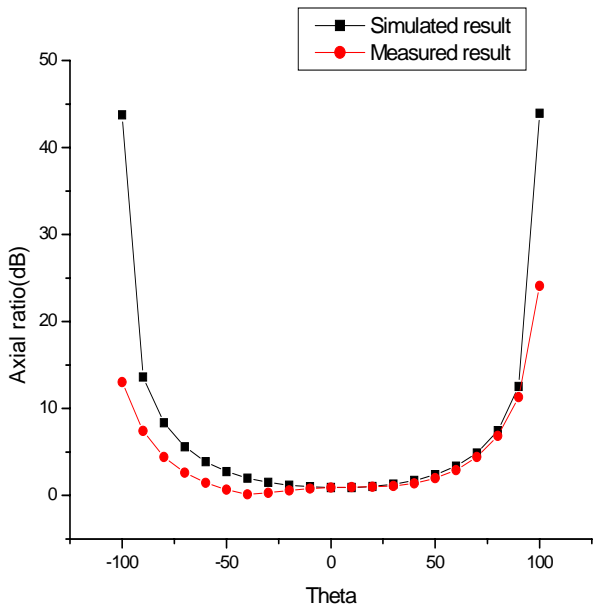

Fig 3(b) Simulated and measured AR at resonant frequency

Fig 3 Simulated and measured plots of the gain and AR at resonant frequency

A comparison is made between the small disk coupled square ring and the normal rectangular patch antenna by the same size, Fig 4 shows the different reflection coefficient from input port (S_{11}):

REFERENCES

- [1] S. ROW, "Design of square-ring microstrip antenna for circular polarization" *Electron. Lett.*, vol.40, pp.93-95, Feb.2004.
- [2] P.Moosavi and L.Shafai. "Characteristics and design of microstrip square ring antennas" , in Proc. 5th Iranian Conf. Electrical Engineering-ICEE97, Tehran, Iran, May 7-9, 1997
- [3] Wen-Shyang Chen, Chun-Kun Wu and Kin-Lu Wong, "Square-Ring Microstrip Antenna with a cross strip for compact circular polarization operation", *IEEE Trans, Antenna propagat*, vol, 47, pp, 1566-1567, Oct, 1999.
- [4] Pedram Moosavi Bafrooei, and Lotfollah Shafai, "Characteristics of Single- and Double-Layer Microstrip Square-Ring Antennas," *IEEE Trans, Antenna Propagat*, vol,47, pp, 1633-1639, Oct, 1999.
- [5] R.Garg and V.S.Reddy, "Edge feeding of microstrip ring antennas," *IEEE Trans. Antennas Propagat.* vol,51, pp, 1941-1946, Oct, 1999
- [6] Amit A. Deshmukh ,Ray, K. P. Ray, and Chine, P. N, "Broadband reactively coupled ring microstrip antenna," Applied Electromagnetic Conference (AEMC), pp,1-4, Dec, 2009.
- [7] Agarwal, Kshitiz; Rao, G.purnachandra; Kartikeyan, M.V; Thumm, M,K, "Wideband dual feed electromagnetically coupled circularly polarized microstrip patch antenna," *Infrared Millimeter wave and 14th International conference on terahertz electronics 2006.* pp:438-438, 12-22 sept. 2006
- [8] C. J. Kaufman, LI jian-feng, SUN Bao-hua, ZHANG jun, LIU Qi-zhong, " Dual frequency and dual circular polarization antenna with high isolation for satellite communication," *ACTA ELECTRONICA SINICA*, Dec, 2009: Vol. 37 No. 12.
- [9] Wenquan Cao, Bangning Zhang, Tongbin Yu, Hongbin Li "A single-feed broadband circular polarized rectangular microstrip antenna with chip-resistor loading " *IEEE Trans, Electron Letters.*, vol. 53, no. 3, pp. 1227-1229, March. 2010.
- [10] Shun-Yun Lin; Kuang-Chih Huang "A compact microstrip antenna for GPS and DCS application," *IEEE Trans, Antenna propagat.*, vol. 53, no. 3, pp. 1227-1229, March. 2005.