

Broadband Four-Way Power Divider for Active Antenna Array Application

Lei Zhang, Xiaowei Zhu, *Member, IEEE*, Peng Chen, Ling Tian and Jianfeng Zhai, *Member, IEEE*
 State Key Lab of Millimeter Wave, Southeast University, Nanjing, 210096, P. R. China

Abstract—A novel four-way power divider based on substrate integrated waveguide is presented. Broadband performance is obtained by using a stepped coaxial line transformer together with tapered substrate integrated waveguides. Simulated and measured results show that good performance of insertion loss and impedance matching is achieved over a broad bandwidth from 4 GHz to 11 GHz. When the proposed power divider is applied for active antenna array, it can be shown that by using appropriate matching networks, gain fluctuation caused by non-ideal return loss and isolation can be alleviated.

I. INTRODUCTION

Active antenna arrays [1] are widely used in modern communication system while the loss of the coaxial cable will have a severe impact on performance. In active antenna system, power dividers/combiners are key components for microwave signal distribution, especially in application of wideband power amplification where power level of a single device is not high enough. Air-filled metal waveguide power dividers show their advantages such as low insertion loss and high-power handling capacities, but the relatively expensive manufacturing and complex transitions to planar circuits limits their application. On the other hand, planar transmission-line (microstrip for example) based power divider suffered from high insertion loss and low power handling capacities. Substrate Integrated Waveguide (SIW) and Half Mode Substrate Integrated Waveguide (HMSIW) have been proposed as attractive techniques for their inherently low loss, low cost, compactness and easy integrated with planar components. Some SIW power dividers have been proposed with good performance [2-9]. In [10], resonant structure-based SIW power dividers are described, but their bandwidth are very low. Broadband travelling-wave four-way power divider is presented [2], but the input matching is rather complicated for manufacture.

In this paper, a broadband SIW four-way power divider is presented. The topology is similar to travelling-wave power divider, as described in [2], but the input matching structure is modified for easy manufacture while providing broadband impedance matching. Simulation results show that proposed power divider exhibits low insertion loss and high return loss over wide bandwidth. When this power divider is connected with active array system, the transfer function from input to individual antenna element is given so wideband gain flatness can be optimized.

II. DESIGN PRINCIPLE

A. Design of SIW four-way power divider

The top view of proposed SIW four-way power divider is shown in Fig. 1. This structure is axially symmetric. It is centrally fed by a current probe through a stepped coaxial line [2]. Four SIWs are used as arms for signal distribution. In each SIW, side walls are realized by arrays of metallic via in relatively thin dielectric substrate. Via spacing of three times of the radius is chosen to minimize leakage losses while staying away from overloading the substrate.

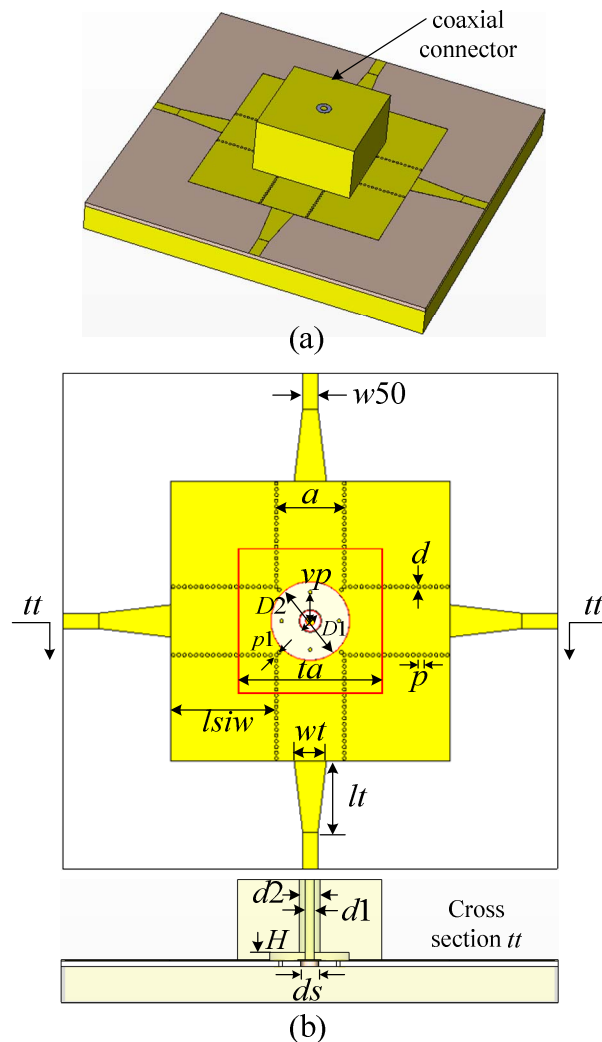

Figure 1. Layout of proposed SIW four-way power divider. (a) 3-D View (b) Top view and cross section of symmetrical plane tt .

In previous literature, dual-disk probe is proposed to provide a broadband impedance matching from the input coaxial line to

radial line [2]. But the structure is rather complicated as more mechanical process is needed to form a closed space on the back side of the substrate. In this paper, stepped coaxial line transformer together with tapered SIWs is used for input matching, as shown in Fig. 1(b). Tapered SIW is formed by guiding posts, as illustrated in [8]. Four additional vias (named as middle via) located just in front of each SIW arm are incorporated to improve return loss. The diameter of inner conductor is also stepped for broadband matching. Input return loss can be optimized by changing vp and spacing between guiding posts. Compared with those described in [2], feeding structure in this paper is simpler while broadband input match is keeping.

B. Power divider connected with antenna array

In active antenna system, power divider is connected with active antenna unit, as shown in Fig. 2. Each antenna unit comprises a power amplifier (PA) and a passive antenna. For simplicity, the input and output reflection coefficients of all PAs are γ_{in} and γ_{out} , respectively. Their linear gain is supposed to be A . The passive antenna can be regarded as one-port network with input reflection coefficient γ_L .

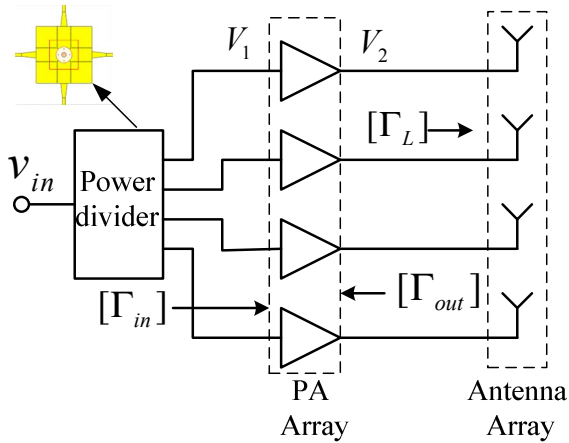

Figure 2. Schematics of antenna array connected with power divider.

In Fig. 2, the input port of the power divider is driven by an incident voltage v_{in} . Let V_1 and V_2 denote voltage vectors at input and output of PA array, i.e. $V_1 = [v_{in} \ v_{in} \ v_{in} \ v_{in}]^T$, $V_2 = [v_{out} \ v_{out} \ v_{out} \ v_{out}]^T$, t represents the transfer coefficient of the power divider from input to either output branch. It can be derived that:

$$V_1 = ([I] + [S][\Gamma_{in}])v_{in}T \quad (1)$$

Where $[\Gamma_{in}]$ is diagonal matrix with non-zero element γ_{in} , $T = [t \ t \ t \ t]$, $[S]$ is scattering matrix of the power divider with the first row and column excluded. Obviously, the off-diagonal elements of $[S]$ indicate isolation between outputs of power divider. $[I]$ is identity matrix.

Similarly, the voltage vector at antenna input is:

$$V_2 = A([I] + [\Gamma_{out}][\Gamma_L])V_1 \quad (2)$$

Where $[\Gamma_{out}]$ and $[\Gamma_L]$ are diagonal matrixes with non-zero element γ_{in} , and γ_{out} , respectively.

By substituting (1) into (2), the above equation can be rewritten as:

$$\begin{aligned} V_2 &= A([I] + [\Gamma_{out}][\Gamma_L])V_1 \\ &= A([I] + [\Gamma_{out}][\Gamma_L])([I] + [S][\Gamma_{in}])v_{in}T_1 \end{aligned} \quad (3)$$

In practice, the amplitude of all reflection coefficients is better than -10dB (lower than 0.32), so the high-order term in (3) can be neglect:

$$V_2 \approx Av_{in}T + ([\Gamma_{out}][\Gamma_L] + [S][\Gamma_{in}])v_{in}T \quad (4)$$

The first term of (4) is ideal output, the second term is frequency-depending interfering signal caused by multiple-reflection and non-ideal isolation. This term should be minimized to improve wideband response of active antenna system.

III. SIMULATE RESULTS AND DISCUSSIONS

A SIW four-way power divider is designed on a Taconic TLX-8 substrate with relative dielectric constant of 2.55 and thickness of 60mil. CST MICROWAVE STUDIO 2011 software is used for full-wave simulation and optimization. The layout parameters of power divider are listed in Table I.

TABLE I
PARAMETERS OF STRUCTURE IN FIG. 1

$w50$	4.1 mm	a	25 mm
$lsiw$	30 mm	d	1 mm
wt	12 mm	p	1.5 mm
lt	26 mm	$d1$	1.3 mm
$d2$	4.4 mm	$D1$	5.3 mm
H	0.5 mm	ds	3.4 mm
$p1$	3.3 mm	ta	60 mm
vp	10 mm	$D2$	26 mm

The simulated frequency responses of power divider with and without matching vias (guiding posts and middle via) are shown in Fig. 3. Compared with power divider without matching vias, the proposed power divider exhibits lower insertion loss and better return loss over wideband, especially in low frequency range below 6 GHz and high frequency range over 10.3 GHz.

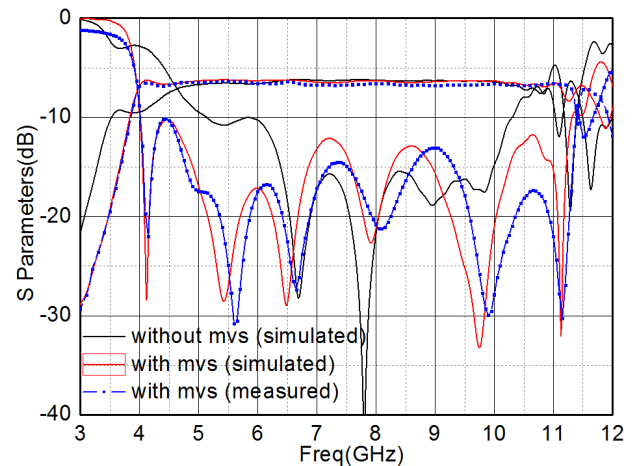

Figure 3. Simulated and measured S parameters of power divider with and without matching vias (mvs)

The photograph of designed four-way power divider is shown in Fig. 4. Four SMA connectors are added for testing. The measured results are also shown in Fig. 3 which includes the loss of SMA connectors. Good agreement between simulated and measured results can be observed in wideband. The discrepancy between the two results is mainly attributed to unexpected tolerance of fabrication and SMA connectors assembling. The measured minimum insertion loss is 0.35dB. The measured and simulated bandwidth over which return loss is better than -10 dB and insertion loss is less than 1 dB is about 7 GHz (from 4 GHz to 11 GHz).

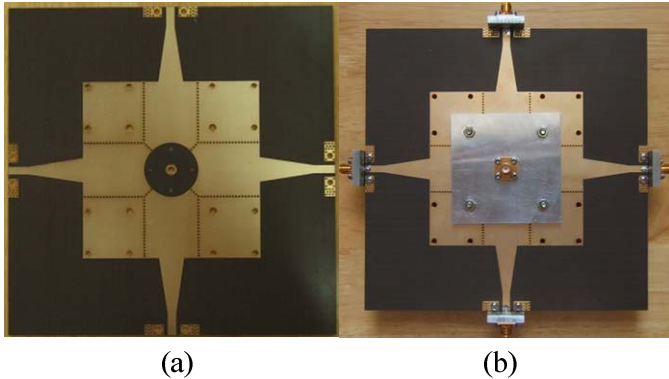

Figure 4. Photograph of broadband four-way power divider (a) before and (b) after adding stepped coaxial line transformer and SMA connectors.

In Fig. 5, the simulate characteristics of two ports network, from power divider input to individual antenna unit, is plotted. For simplicity, the amplitude of all reflection coefficients is set to be 10 dB, their phase is assumed to zero degree. As explained in (4), the non-zero return loss and non-ideal isolation between output ports of power divider cause gain fluctuation. This frequency response can be improved by incorporating appropriate matching networks with power amplifier, as shown in Fig. 6. In order to preserve output power of PA, only input matching network is added. By optimizing this matching network, gain fluctuation in frequency response can be alleviated, as depicted in Fig. 5. The optimized parameters of matching network are summarized in Table II.

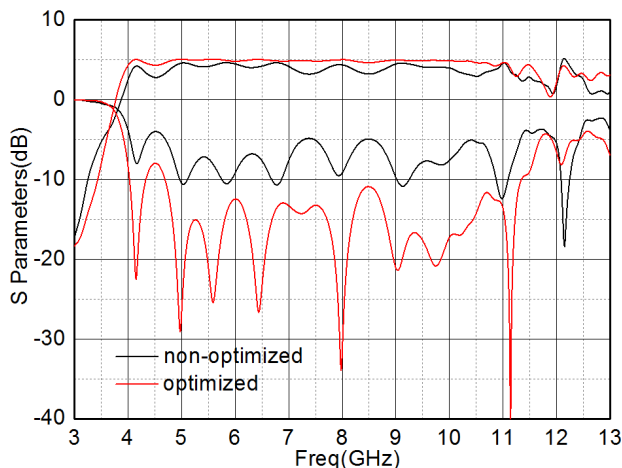

Figure 5. Frequency responses of signal path from power divider input to antenna unit.

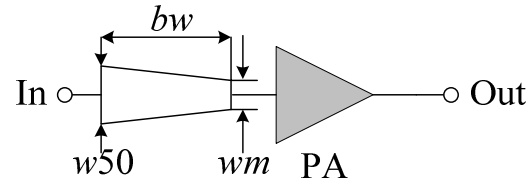

Figure 6. Schematics of power amplifier with input matching taper.

TABLE II
PARAMETERS OF STRUCTURE IN FIG. 6

bw	26 mm	wm	0.8 mm
------	-------	------	--------

IV. CONCLUSIONS

A novel four-way SIW power divider has been proposed. Low insertion loss and good return loss were achieved over wideband from 4 GHz to 11 GHz. This structure has been cooperated with active antenna array and the transfer function was deduced. Gain fluctuation could be improved by optimizing the matching network. It is expected that these power dividers can be widely used in wideband millimeter-wave communication circuit especially active antenna system.

ACKNOWLEDGMENT

This work was supported by National Science and Technology Major Project (2013ZX03001017-003), and Research Fund for the Doctoral Program of Higher Education of China under grant (20100092120013).

REFERENCES

- [1] D. M. Pozar, "The active element pattern," *IEEE Trans. Antennas Propag.*, vol. 42, no. 8, pp. 1176–1178, August 1994.
- [2] K. Song, and Y. Fan, "Broadband travelling-wave power divider based on substrate integrated rectangular waveguide," *Electronics Letter.*, vol. 45, no. 12, pp. 631–632, December 2009.
- [3] X. Zou, C. M. Tong, and D. W. Yu, "Y-junction power divider based on substrate integrated waveguide," *Electronics Letter.*, vol. 47, no. 12, pp. 1375–1376, December 2011.
- [4] D. S. Eom, J. Byun, and H. Y. Lee, "Multilayer Substrate Integrated Waveguide Four-Way Out-of-Phase Power Divider," *IEEE Trans. Microwave Theory Tech.*, vol. 57, no. 12, pp. 3469–13476, December 2009.
- [5] L. Zhang, X. W. Zhu, and J. Zhai, "Design of wideband planar power dividers/combiners," *Microwave Workshop Series on Millimeter Wave Wireless Technology and Applications (IMWS), 2012 IEEE MTT-S International*, pp. 173–175, 2012.
- [6] Q. X. Chu, and J. M. Yan, "A two-layer planar spatial power divider/combiner," *Microwave Symposium Digest, 2009. IEEE MTT-S International*, pp. 989–992, June 2009.
- [7] H. Jin and G. Wen, "A novel four-way ka-band spatial power combiner based on HMSIW," *IEEE Microwave Wireless Component Letter.*, vol. 18, no. 8, pp. 515–517, August 2008.
- [8] T. Y. Seo, J. W. Lee, S. C. Choon, and T. K. Lee, "Radial guided 4-way unequal power divider using substrate integrated waveguide with center-fed structure," *Proc. Asia-Pacific Microw. Conf.*, pp. 2758 - 2761, December 2009.
- [9] B. Liu, B. tian, Z. S. Xie, et.al, "A novel image transition in half mode substrate integrated waveguide power divider design," *Cross Strait Quad-Regional Radio Science and Wireless Technology Conference (CSQRWC)*, pp. 621–624, 2011.
- [10] K. Song, Y. Fan and Y. Zhang, "Eight-way substrate integrated waveguide power divider with low insertion loss," *IEEE Trans. Microwave Theory Tech.*, vol. 56, no. 6, pp. 1473–1477, June 2008.