

# An RF Self-interference Cancellation Circuit for the Full-duplex Wireless Communications

Binqi Yang, Yunyang Dong, Zhiqiang Yu, Jianyi Zhou  
 State Key Laboratory of Millimeter Waves  
 School of Information and Engineering  
 Southeast University Nanjing, 211189, P. R. China

**Abstract-** This paper presents the design of an RF self-interference cancellation circuit for the full duplex wireless communication systems. Excellent performance is achieved. The RF cancellation circuit provides more than 50dB self-interference cancellation across a 50MHz bandwidth. The transmitted power can be quite high for very low IMD products will be introduced in the circuit. The real time optimization algorithm is used to adaptive adjust the parameters of the circuit according to the change of the channel.

**Keywords-** Full-duplex wireless; Self-interference cancellation; Simplex Method

## I. INTRODUCTION

The spectrum resource is very precious in wireless communication systems. Current wireless communication systems employ either a time-division duplexing or frequency-division duplexing approach to bidirectional communication, of which approaches are so-called Half-duplex communication techniques. The full-duplex is a more efficient way in terms of utilization of the spectrum resource. A full duplex radio can transmit and receive on the same frequency at the same time, so it can double the efficiency of spectrum.

The benefits of full duplex wireless communication have led researchers to explore how to build a practical full duplex radio. The main challenge in achieving full-duplex is to cancel the strong self-interference at the received side from the transmit antenna of a node, which can be 60-90dB stronger than received signal. Luckily, the self-interference is strongly correlated to transmit signals in the near field. Using knowledge of the transmission to cancel self-interference is feasible. Recent work has explored some self-interference cancellation techniques and practical implementations of full-duplex wireless nodes [1], [3], [5]. The antenna placement techniques, the RF self-interference cancellation and the digital cancellation are employed to achieve larger attenuation of the self-interfering signal.

This paper presents the design of an RF self-interference cancellation circuit which can realize adaptive self-interference cancellation in full duplex wireless. Both the antenna Separation and the RF cancellation technique are used and more than 52dB reduction is achieved across a 50MHz bandwidth. The operation frequency ranges from 2.3GHz to 2.4GHz. The maximum TX power can be up to 25dBm.

## II. DESIGN

The frequency response of the TX antenna and the RX antenna is very useful for the design and optimization of the

cancellation circuit. Figure 1 shows the frequency response observed from separated transmit and receive antennas (commercial Omni-directional antennas, separated by 13cm). The loss is about 23dB.

Figure 2 shows the block diagram of the cancellation circuit. A vector modulator is used as the programmable phase shifter and attenuator to obtain the invert of self-interference signal. However, any radio that inverts a signal only through adjusting phase will always cause bandwidth constraint [1,2], like the *antenna cancellation* technique [2]. To obtain inverse of wideband signals, a fixed delay line is used for achieving same group delay in invert signal path and self-interference path. The vector modulator provides a fine-grained control to match amplitude and phase for invert signal path to optimal cancellation.

If the frequency response of self-interference channel is flat the channel frequency response of self-interference channel can be modeled as follows:

$$H_a(j\omega) = H_a e^{j\omega\tau_a} e^{j\varphi_a} \quad (1)$$

where  $H_a, \varphi_a, \tau_a$  are amplitude, phase offset and delay of self-interference channel respectively. The simplify frequency response of RF cancellation path is given by:

$$H_c(j\omega) = G e^{j\omega\tau_c} e^{j\varphi_c} \quad (2)$$

where  $G, \varphi_c, \tau_c$  are amplitude, phase offset and delay of cancellation path respectively. In a perfect cancellation:

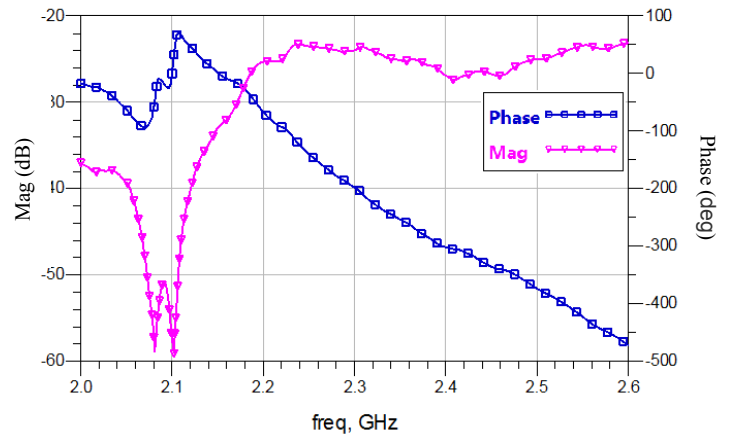

Fig 1. Frequency response observed from separated transmit and receive antennas in normal laboratory environment

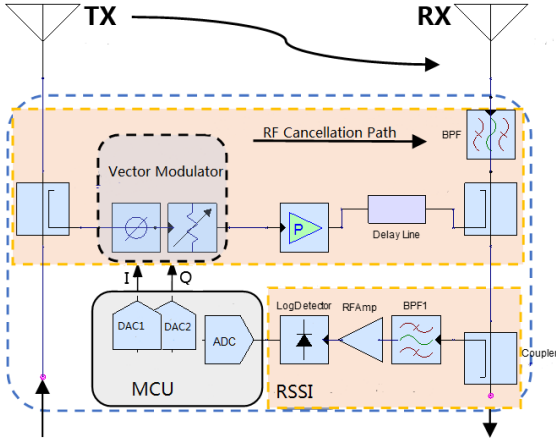

Fig 2. Block diagram of self-interference cancellation circuit. Passive delay line and vector modulator provide control to match amplitude and phase for the wideband interference

$$H_a(j\omega) + H_c(j\omega) = 0 \quad (3)$$

For all  $\omega$  in band, we have:

$$H_a e^{j\omega\tau_a} e^{j\varphi_a} = -G e^{j\omega\tau_c} e^{j\varphi} \quad (4)$$

$$-\frac{H_a}{G} e^{j(\varphi_a - \varphi)} = e^{j\omega(\tau_c - \tau_a)}$$

Therefore, we have:

$$\begin{aligned} \tau_c &= \tau_a \\ G &= H_a \\ \varphi &= \varphi_a + \pi \end{aligned} \quad (5)$$

It is obvious that to cancel in a width band, a radio needs to obtain the invert signal which is perfect negative of the transmit signal at all instants. The passive delay line is one of the key component for wide cancellation bandwidth.

A 15dB strip-line directional coupler is used to provide the transmit signal to the invert signal path as the self-interference reference. Another 15dB strip-line directional coupler is used as combiner to add invert signal and self-interference signal. The amplitude of the vector modulator can be controlled from a maximum of  $-7.5$  dB to less than  $-37.5$  dB at 2.35GHz. An additional 20dB RF amplifier is used in the RF cancellation path. Hence, the amplitude of RF cancellation path can be controlled from  $-17.5$ dB to  $-47.5$ dB, covering the range of self-interference channel.

The RF amplifier has very high P1dB and OIP3 specifications, so this cancellation design will not introduce too much non-linear distortion in a high transmit power. While this circuit can in theory provide a perfect cancellation to wideband signals, there is a practical limitation: the frequency response of self-interference channel is non-flat (Figure 1). It is hard to obtain a perfect invert of self-interference.

A logarithmic detector is used as the received signal strength indication (RSSI). A basic approach to estimate the state of cancellation is measuring the residual signal power after cancellation. This cancellation design can automatically adjust the phase and amplitude to minimize the residual signal

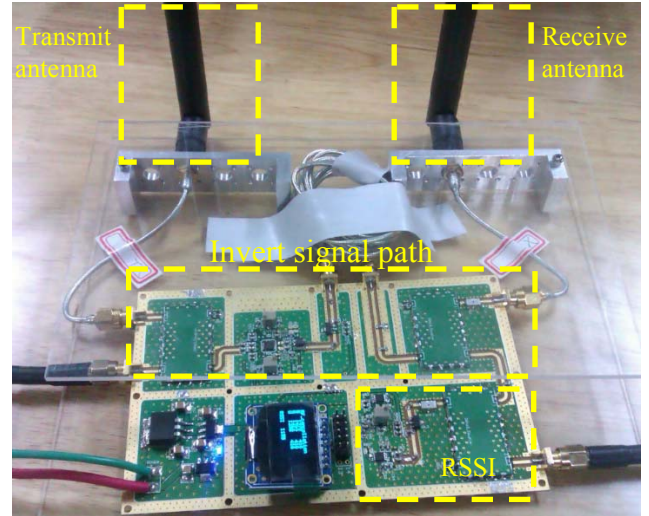

Fig 3. The implementation of cancellation design: build with two Omni-directional antennas and a cancellation circuit.

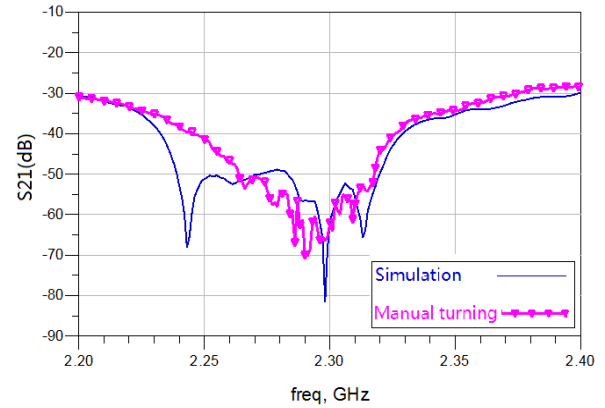

Fig 4. Cancellation performance with manual turning vs simulation.

power in response to channel changes by sampling RSSI.

Figure 3 shows the implementation of cancellation design. The invert signal path provides the inverse of self-interference. The RSSI value provides the residual signal energy after cancellation.

Figure 4 shows a cancellation result of manually turning the phase and amplitude of invert signal path to optimize cancellation at the received side. We use vector network analyzer N5230A to measure the S-parameter. The RF cancellation circuit provides around 50dB reduction over a 60MHz bandwidth. As a comparison, the figure also shows the simulation result using an ideal vector modulator model, measured S-parameter of amplifier and self-interference channel. The cancellation measured is imperfect across entire band. The key reason is the length deviation of delay line and that the frequency response of interference channel is non-flat (Figure 1).

### III. AUTO-TURNING

The results in Figure 4 show that, if the amplitude and phase offset are set appropriate, the circuit can provide a good cancellation across a wide bandwidth. In this section we

describe an algorithm that can quickly and accurately self-turn the cancellation circuit.

The I and Q inputs to the vector modulator set the gain and phase between input and output. We have built a RSSI model with changing I and Q inputs to the vector modulator,  $v_i$  and  $v_q$ . For brevity we give the equation directly:

$$\begin{aligned}
 H(j\omega) &= H_a \cdot e^{j\varphi_a} \cdot e^{j\omega\tau_a} \\
 &+ H_{coupler} \cdot H_{VM} \cdot H_{Amp} \cdot e^{j\omega\tau_a} \cdot H_{coupler} \\
 &= e^{j\omega\tau_a} \cdot (H_a \cdot e^{j\varphi_a} + \\
 &0.317 \times 10^{11.59} \left[ \sqrt{\left(\frac{V_i-0.5}{0.5}\right)^2 + \left(\frac{V_q-0.5}{0.5}\right)^2} \right]^{0.03895} e^{-11.81 j \arctan\left(\frac{V_i-0.5}{V_q-0.5}\right)}
 \end{aligned} \tag{6}$$

where  $H_a$ ,  $\varphi_a$ ,  $\tau_a$  are amplitude, phase offset and delay of self-interference channel. The RSSI value is the magnitude of Equation (6). We add random amplitude changes and phase jitter presenting the dynamic environment when simulation. We plot the RSSI output with changing I and Q inputs to vector modulator in Figure 5. There is a deep null exists at the optimal point. The simplex method is used for finding the optimal point. For two variables, a simplex is a triangle and the method is a pattern search that compares values at the three vertices of triangle. The worst vertex will be replaced with a new vertex. The greatest advantage is that simplex method does not use derivatives. The algorithm can converge to the optimal point in 8-15 iterations and each iteration requires 1-4 measurements, less than 2 measurements required in most cases. Each measurement involves an amplitude and phase adjustment followed by RSSI sampling. It is effective and computationally compact. We omit the mathematics and plot the result of 8 iterations after the initialization of algorithm in Figure 6. Obviously, the best vertex of triangle is close to the optimal point. An efficient algorithm should perform less measurement in each iteration.

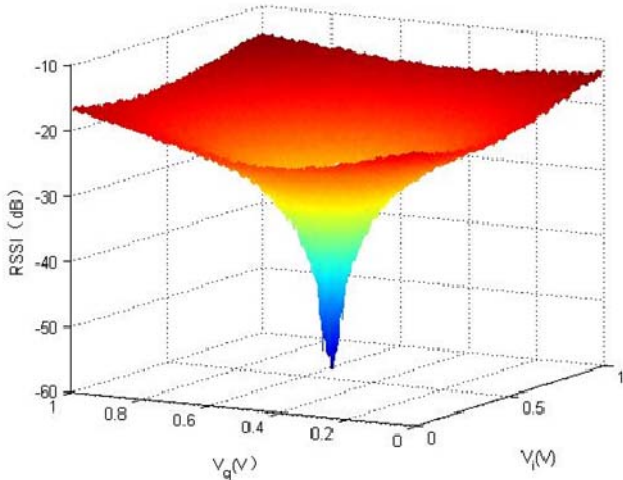

Fig 5. The RSSI output with changing I and Q inputs to the vector modulator,  $v_i$  and  $v_q$ .

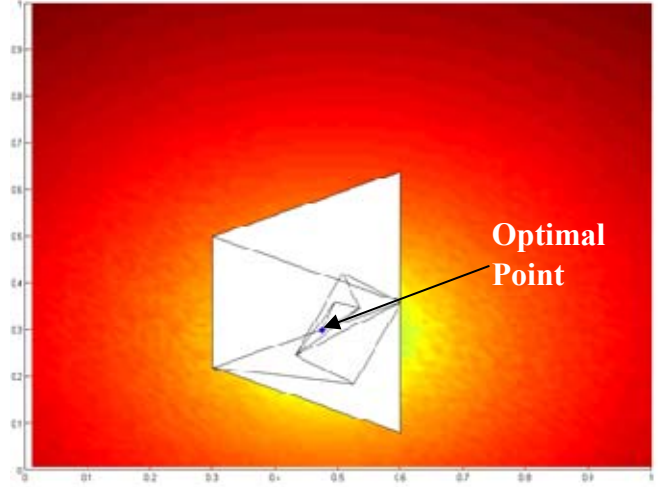
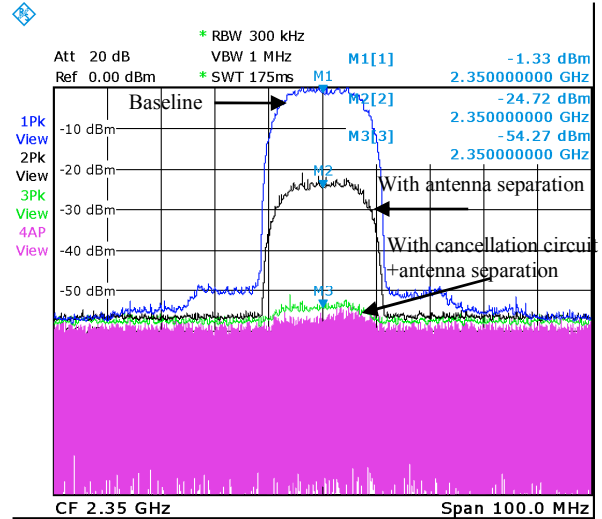

Fig6. The result of 8 iterations after the initialization of algorithm

In implementation of cancellation design, auto-tuning algorithm is executed on a mixed signal microcontroller with 12-bit ADC and 12-bit DAC.

#### IV. EXPERIMENTAL RESULTS

In this section, we provide experimental results for performance of the adaptive self-interference cancellation. We program a vector signal generator N5182A to generate a wideband 15MHz digital modulation signal with a center frequency of 2.35GHz which include MSK, QPSK, 16-QAM, and 64-QAM. Using spectrum analyzer FSL6 to observe signals at the received side. The results are summarized in Table 1. Figure7 shows the spectrum of residual signal after auto-tuning cancellation at the received side. The circuit provides isolation of 52dB for the self-interference.



Date: 23.MAY.2013 14:18: (a) 16-QAM

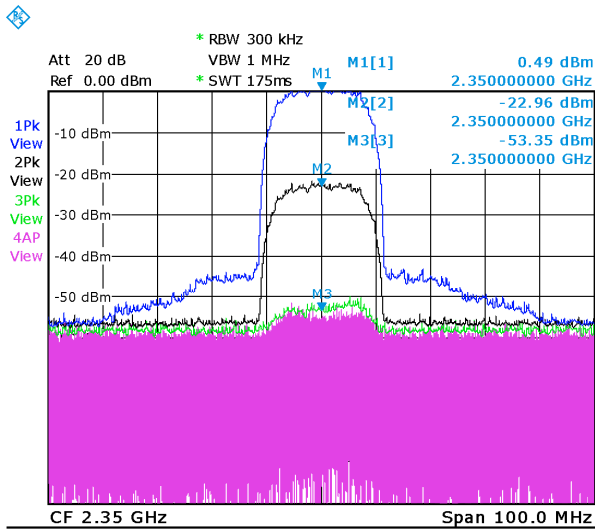

Date: 23.MAY.2013 14:39:44 (b) 64-QAM

Fig 7. Spectrum snapshots showing the effect of adaptive cancellation:  
(a) 16-QAM (b) 64-QAM

TABLE I: The results of adaptive cancellation

	MSK	QPSK	16-QAM	64-QAM
Baseline	-0.27 dBm	-1.01 dBm	-1.33 dBm	0.49dBm
Antenna Separation	-22.24dBm	-24.18dBm	-24.72dBm	-22.96dBm
Total Reduction	-49.24dBm	-53.75dBm	-54.27dBm	-53.35dBm
RF Cancellation	27dB	29.57dB	29.55dB	30.39dB

## V. CONCLUSION

This paper presents an RF interference cancellation circuit for the full duplex wireless communication with strip-line directional couplers, a vector modulator and a passive delay line. This circuit provides around 52dB self-interference cancellation in a very wide frequency band. It can accurately and quickly optimize the cancellation for dynamic environment. With this RF cancellation mechanism, if further reduction is obtained by digital interference cancellation techniques, a practical full duplex communication will be established soon.

## ACKNOWLEDGEMENT

This work is supported in part by the National Natural Science Foundation of China under Grant 60702163, in part by the National Science and Technology Major Project of China under Grant 2010ZX03007-002-01, and 2011ZX03004-003.

## REFERENCES

- [1] Jain, M., Choi, J. I., Kim, T., Bharadia, D., Seth, S., Srinivasan, K., ... & Sinha, P. (2011, September). Practical, real-time, full duplex wireless. In Proceedings of the 17th annual international conference on Mobile computing and networking (pp. 301-312). ACM.
- [2] J. I. Choi, M. Jain, K. Srinivasan, P. Levis, and S. Katti. Achieving single channel, full duplex wireless communication. In Proceedings of the sixteenth annual international conference on Mobile computing and networking, MobiCom '10, pages 1–12, New York, NY, USA, 2010. ACM.
- [3] M. Duarte and A. Sabharwal. Full-duplex wireless communications using off-the-shelf radios: Feasibility and first results. In Forty-Fourth Asilomar Conference on Signals, Systems, and Components, 2010.
- [4] Sahai, A., Patel, G., & Sabharwal, A. (2011). Pushing the limits of full-duplex: Design and real-time implementation. arXiv preprint arXiv:1107.0607.
- [5] Hong, S. S., Mehlman, J., & Katti, S. (2012). Picasso: flexible RF and spectrum slicing. ACM SIGCOMM Computer Communication Review, 42(4), 37-48.
- [6] John H. Mathews, Kurtis D. Fink. Numerical Methods Using Matlab. Forth Edition, Chapter 8, Numerical Integration, Page 399-425