

# A reconfigurable frequency selective surface for tuning multi-band frequency response separately

Jialin Yuan<sup>1</sup>, Shaobin Liu<sup>1\*</sup>, Xiangkun Kong<sup>1,2</sup>, Huan Yang<sup>1</sup>.

<sup>1</sup>College of Electronic and Information Engineering, Nanjing University of Aeronautics and Astronautics, Nanjing 210016, China

<sup>2</sup>Jiangsu Key Laboratory of Meteorological Observation and Information Processing, Nanjing University of Information Science and Technology, Nanjing 210044, China

**Abstract-** A reconfigurable frequency selective surface (FSS) is presented in this paper. The tunable FSS is based on a common FSS comprising annular ring slot and cruciform structure cells. The tuning of the reconfigurable surface is shown numerically to be possible by incorporating tuning varactors into the structure. Using varactors on both layers, a reconfigurable frequency response is achieved, which has three modes of center frequency. Numerical simulations show that lower and upper frequency can be tuned separately by altering the capacitance of the loaded varactors. So that multiple-band frequency response is electronically tunable separately. Besides that, the FSS is stable with different polarizations and incident angles.

## I. INTRODUCTION

Frequency selective surface (FSS) are periodic surfaces, which provide spatial filtering have been widely used for electromagnetics, microwave, antennas, radar and satellite communications[1-8]. In the past few decades, tunable frequency filters have attracted a lot of interest over the years as research commenced. A frequency selective surface with miniaturized elements were proposed in[4,5]. The center frequency tuning with a fixed bandwidth and bandwidth tuning with a fixed center frequency can be achieved by mounting varactors[6]. A dual-band frequency selective surface with large separation can be achieved when varactors are employed[7]. Plasma frequency selective surface has been studied in [8], they replace metal with plasma in the FSS so that can be tunable by varying the density in the plasma elements, but it's a complicated and numerically expensive process. A novel symmetric anchor-shaped active frequency selective surface (AFSS) with a wide tuning frequency range is proposed in [9], a wide tunable frequency range from 1.76 to 2.45 GHz with a relative bandwidth of 33% is achieved.

A reconfigurable frequency selective surface (FSS) is presented in this paper whose multiple-band frequency response is electronically tunable separately. This FSS has two arrays of structures printed on either side of a thin flexible substrate by connecting the structures on each layer. The frequency tuning capability of the proposed FSS is demonstrated through numerical simulations using Ansys HFSS software.

## II. DESIGN PROCESS AND RESULTS

### A. Design process

The proposed tunable FSS structure is shown in Fig.1, including the design parameters. A three-dimensional (3D) view of the unit cell is shown in Fig. 1(a). As we can see,

the structure is composed of two layers separated by a thin substrate. The substrate relative permittivity is  $\epsilon_r=2.2$ . On the top surface of the unit cell, four chip capacitors are loaded symmetrically around the circle, on the bottom surface, there is a wire grid and four chip capacitors are loaded between the gaps of the grid. For this particular structure, when the unit cell is expanded periodically in the x- and the y-axis directions, a tunable FSS is obtained.

Geometrical dimensions of the structure as follow:

TABLE I

GEOMETRICAL DIMENSIONS OF THE STRUCTURE

$L_1$	$h$	$R_0$	$R_i$	$L_2$	$w$
18.2mm	0.7mm	8mm	6.5mm	8.6mm	0.5mm

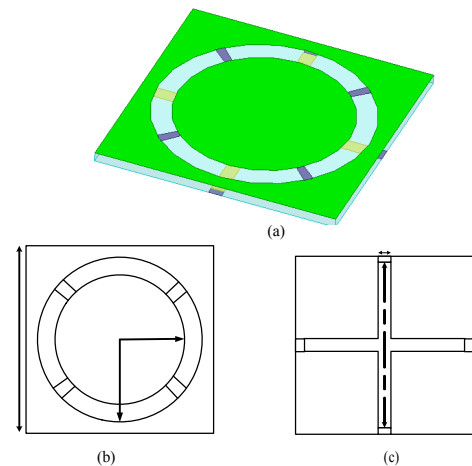

Fig.1. One-unit cell is shown.(a) 3D view of a unit cell. (b) top view (b) back view.

We use Ansys HFSS to calculate the results, we should choose appropriate capacitance values that are incorporated into the design. The simulation model is one unit cell periodic boundary and excited by an incident plane wave, which is set at different incident angles and with different polarizations. C1 is inserted in the circular slot of the top surface symmetrically and C2 is loaded between the gaps of the grid. The transmission coefficients at normal incidence are shown as the simulated results in Fig.2. There are three band-pass responses. When we keep C2 unchanged, and change C1 from 0.3 pf to 0.5 pf, the upper center frequency moves toward lower frequency. The second case is that we keep the C1 unchanged but set C2 as 1.6 pf, 2.5 pf, 4.0pf, the lower center frequency moves toward to the lower frequency. The result shows that the lower and upper center frequency can tuned separately by changing

the capacitances  $C1$  and  $C12$ , but the performance of band-pass is well kept.

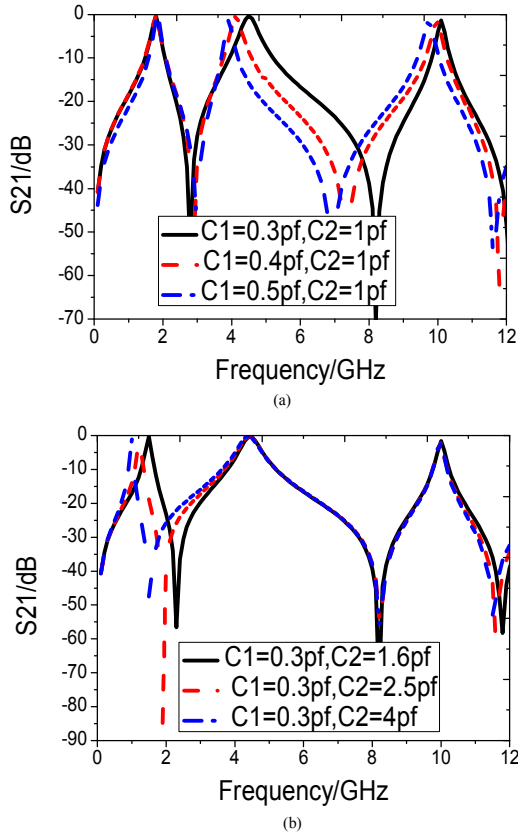

Fig.2.the S parameter of the FSS with the different values of the capacitance  $C1$  and  $C2$

### B. Analysis

Fig.3 shows the electric field distributions at  $1.8GHz$  and  $4.75GHz$  which correspond to the lower and upper center frequency. It can be found that the electric resonance occurs in the crossed patch on the bottom and the circular slot on the top. Based on this current distribution, the corresponding equivalent circuit model is given in Fig3(c)[10].

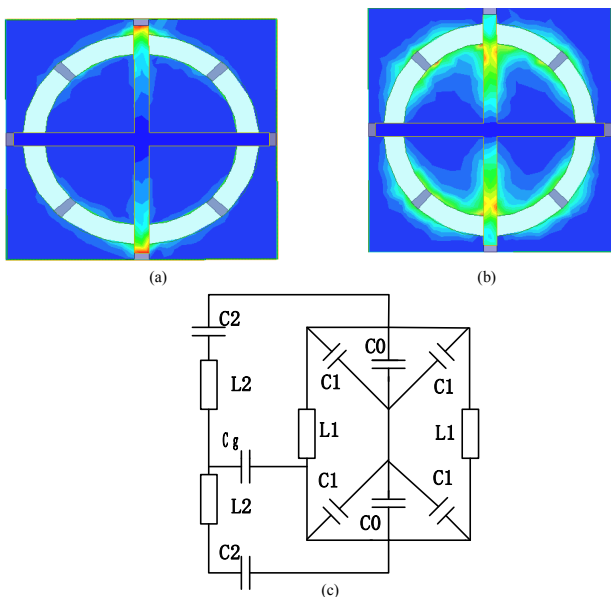

Fig.3. electric field distribution of the proposed FSS (a) at  $1.80GHz$  (b) at the  $4.75GHz$  (c)equivalent circuit model

$L1$  can be understood as the equivalent inductance of each vertical slits on both sides of the metal patch on the top.  $C0$  can be understood as the equivalent capacitance of each ring slot gap on both sides of the metal on the top.  $Cg$  is the equivalent capacitance of the gap between the upper and lower layers. Apparently,  $L2$  models the traces of the bottom grid and  $C1, C2$  are the capacitances which are loaded on the both surfaces.

### C. Stable performance

The stable performance of the FSS is very important in some special application. Fig.4 gives the simulation results. We can find that incident angle changes have greater impact with TM polarization. But there is no more difference when the polarization is changed. To sum up, the ring slot surface is stable for incident angles within  $30\text{ deg}$  and different polarizations.

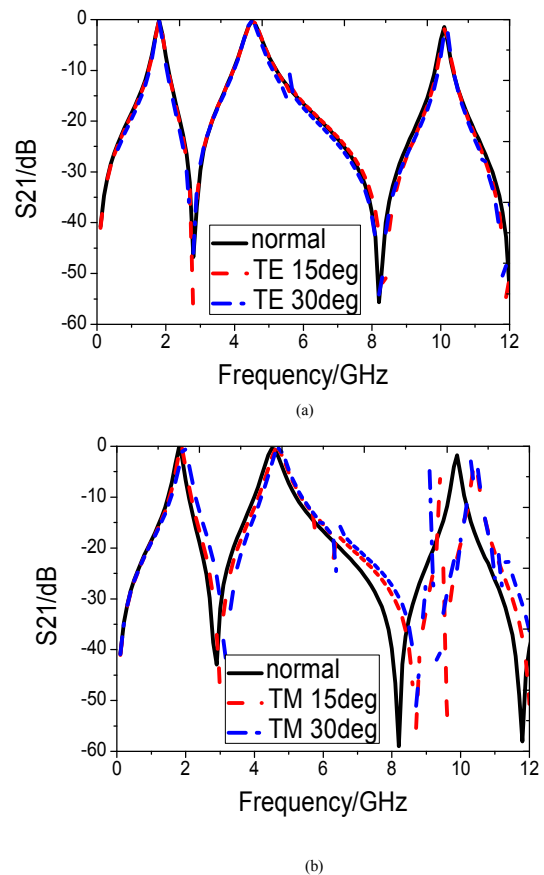

Fig.4 . the S paramant of the FSS with different polarizations and incident angles. (a) TE (b) TM

### III. CONCLUSION

In this paper, a multiple-band tunable frequency selective surface is proposed. The FSS unit is consisted of a ring slot and cruciform structure which are loaded with varactors in parallel. The frequency tuning capability is achieved by changing the value of capacitance through numerical simulations. The lower and upper center frequency can be tuned separately. By the way, a equivalent circuit is given through the field analysis. Such a FSS has broad application prospects in radar and satellite communications .

#### ACKNOWLEDGMENT

This work was supported by the supports from Chinese Specialized Research Fund for the Doctoral Program of Higher Education (grant No. 20123218110017), the Jiangsu Province Science Foundation (Grant No. BK2011727), and the Foundation of Aeronautical Science (No. 20121852030), Outstanding Doctoral Dissertation in NUAA (Grant No. BCXJ11-05) and the Open Research Program in Jiangsu Key Laboratory of Meteorological Observation and Information Processing (Grant No. KDXS1207).

#### REFERENCE

- [1] T. K. Wu, *Frequency-Selective Surface and Grid Array*. New York: Wiley, 1995.
- [2] B. A. Munk, *Frequency-Selective Surfaces: Theory and Design*. New York: Wiley, 2000.
- [3] Farhad Bayatpur, Kamal Sarabandi "Design and Analysis of a Tunable Miniaturized-Element Frequency-Selective Surface Without Bias Network" *IEEE Trans. Antennas Propag.* vol. 58, no. 4, pp:1214-1219, April 2010
- [4] K. Sarabandi and N. Behdad, "A frequency selective surface with miniaturized elements," *IEEE Trans. Antennas Propag.* vol. 55, no. 5, pp. 1239–1245, May 2007
- [5] Farhad Bayatpur and Kamal Sarabandi, "A Tunable, Band-Pass, Miniaturized-Element Frequency Selective surface: Design and Measurement" *Antennas and Propagation Society International Symposium, 2007 IEEE*, pp.3964-3967, June 2007
- [6] Farhad Bayatpur and Kamal Sarabandi, "A Tunable Metamaterial Frequency-Selective Surface With Variable Modes of Operation" *IEEE Trans. Microwave theory and technology* vol 57, no. 6, pp.1433-1438, June 2009
- [7] Zhou hang, Qu shao-bo, "Dual-band frequency selective surface with large band separation and stable performance". *Chin. Phys. B.* vol. 21, no. 5 (2012), pp. 054101, 1-053101, 4
- [8] Ted Anderson, Igor Alexeff, James Reynolds, "Plasma Frequency Selective Surfaces" *IEEE Trans. Plasma Science* .vol 35, No. 2 APRIL 2007
- [9] Liang Zhang, Guohui Yang, "A Novel Active Frequency Selective Surface With Wideband Tuning Range for EMC Purpose" *IEEE Trans. Magnetics*, vol. 48, No. 11, November, 2012
- [10] Marcello D'Amore, Valerio De Santis, Mauro Feliziani, "Equivalent Circuit Modeling of Frequency-Selective Surfaces Based on anisotropic Transparent Thin Films" *IEEE Trans. on Magnetics*. vol. 48, no. 2, pp. 703-706. February 2012