

# Simulation study of a waveguide power combining network

Z.X. Wang B. Xiang M.M. He W.B. Dou  
State Key Lab of Millimeter Waves, Southeast University  
Nanjing, 210096, P.R. China

*Abstract-* A waveguide based four way millimeter-wave power combining network is studied using HFSS in this paper. The power combining network is composed of a power divider sub-network, four metal PCB cavities and a power combiner sub-network. A compact waveguide directional coupler is designed to act as the power combiner and power divider. Parameters and shapes of the PCB cavities are carefully studied to avoid the resonant modes of the cavities, and a rhombus-like PCB cavity which has good transmission coefficient is presented.

## I. INTRODUCTION

The demand for high millimeter-wave output power has greatly increased in the military and civil field in Recent years. However, the output power from an individual solid-state device is rather modest at millimeter-wave frequencies, and the effective way to obtain higher output power is to combine the output powers from a number of solid-state devices. Conventional hybrid-type power-combining techniques based on printed circuits, such as the Wilson power divider, Lange coupler, and branch-line coupler, suffer from heavy power loss and narrow bandwidth at millimeter frequencies [1]. To avoid the drawbacks of circuit-type power combiners, quasi-optical [2-6] and waveguide-based [7-11] power-combining approaches have been proposed because of their low insertion loss, and their high power-combining efficiency. Compared to quasi-optical power combining system, the waveguide-based power combining network takes less space, which is attractive in many practical applications.

A compact four-way waveguide-based power combining network is proposed for high power combining application at frequency band 75~77GHz in this paper. The designed power network is composed of a power divider sub-network, a power combiner sub-network and four PCB cavities. The power divider/combiner sub-network consisting of three waveguide directional couplers are carefully designed in a compact size using standard WR12 waveguide and the shape and parameters of the PCB cavities are also studied.

## II. DESIGN OF THE POWER COMBINING NETWORK

### A. Logic structure of the power combining network

In this paper, we present a design of four way waveguide power combining network at V-band, the logic diagram is shown in Fig.1, where the input electromagnetic wave is divided into four way waves by the three dividers, and at the output side the four way waves are combined by three combiners. Between the divider sub-network and the combiner sub-network, there are four PCBs which are used

to install the amplifier chips in the future and set in their respective metal cavities.

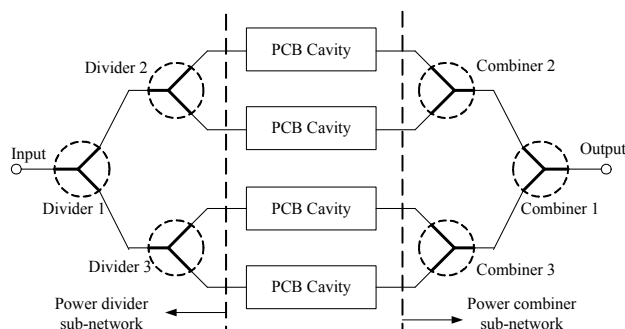

Fig. 1 Logic diagram of the power combining network

### B. Design of the directional coupler

Waveguide directional couplers are used as power divider and power combiner in this design, the structure of an usual broad-wall waveguide directional coupler is shown in Fig.2, the two waveguide are coupled through several slots in the broad wall. When the directional coupler is used as power combiner, the two input ports say port 1 and port 2 are well isolated. However, in a Tee junction power combiner the isolation between the two input ports is good only when the incidences are of same amplitude in phase ( H plane Tee junction) or same amplitude out of phase( E plane Tee junction), and this condition is easy to be damaged in a complex network of long transmission lines, which will finally degrade the performance of the power combining network.

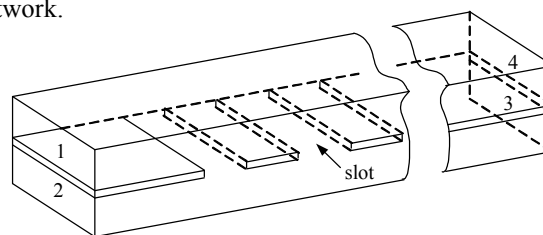
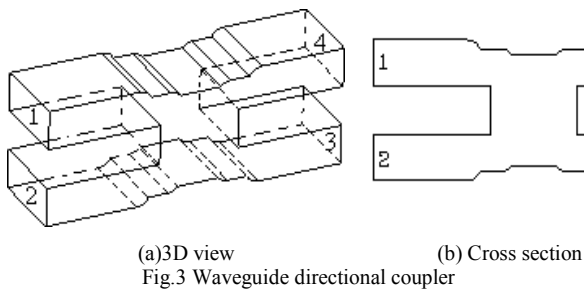

Fig.2 Structure of an usual waveguide broad-wall directional coupler

To reduce the size of the power combining network, the waveguide (WR12) directional coupler is designed in a compact form with only one coupling slot and circular arc structure for matching, see Fig.3, the simulated scattering parameters of the directional coupler are shown in Fig.4, the reflection and isolation are good than -20dB at 75~77GHz.



(a) 3D view  
Fig.3 Waveguide directional coupler

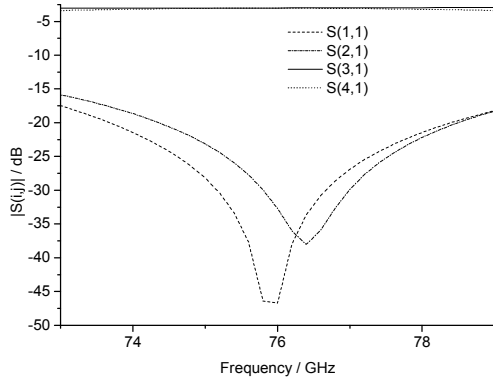
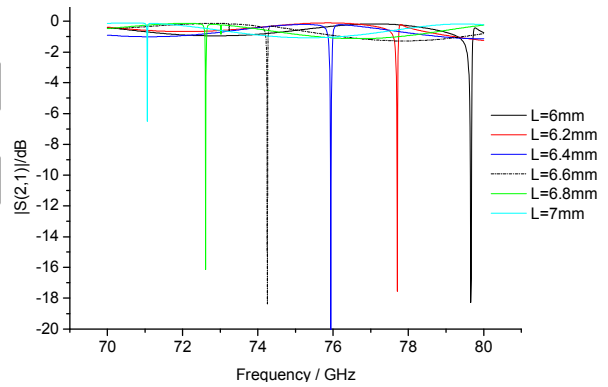
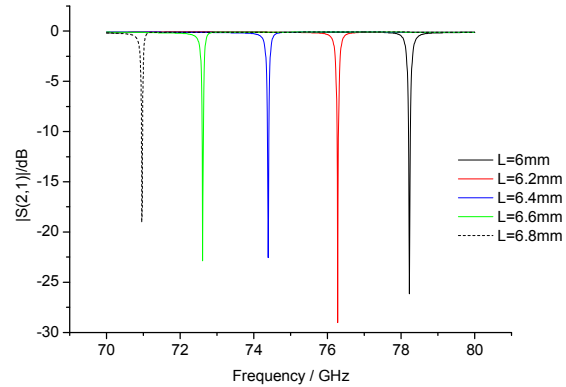

Fig.4 Scattering parameters of the waveguide directional coupler



(a)  $W=4.7\text{mm}, H=1.7\text{mm}$



(b)  $W=4.2\text{mm}, H=1.7\text{mm}$

Fig.6 Transmission coefficient of the rectangular cavity

### C. Design of the PCB cavity

The transmission performance of the PCB circuit is greatly affected by the shape and size of the metal cavity in which the PCB circuit is installed, and thereby affect the performance of the power combining network. At first, a microstrip line printed on Rogers 5880 dielectric board (thickness 0.127mm) and then installed in a rectangular metal cavity is studied, see Fig.5, where the two ends of the cavity are connected to the waveguide through microstrip-waveguide transitions, making it easy to connect with the power divider network and the power combiner network. The cavity height  $H$  is set to 1.7mm, and then calculate the S-parameter of the PCB cavity with different cavity length  $L$  and cavity width  $W$  using HFSS12. The simulated transmission results of the rectangular cavity are shown in Fig.6, it is clear that for different values of  $L$  and  $W$  there exist bad performance point at certain frequencies, the reason is supposed to be that there inspired resonant modes in the rectangular cavity, which do damage to the transmission characteristics of the metal cavity.

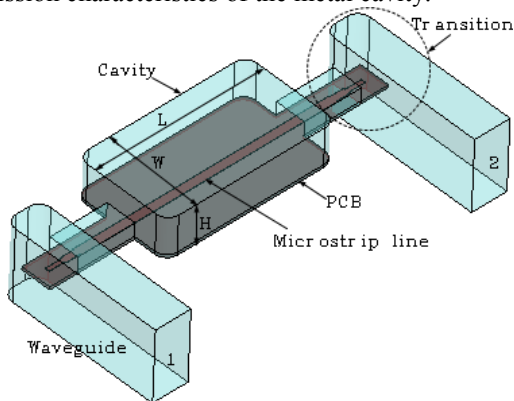

Fig.5 Rectangular PCB cavity

It is possible to make the bad performance point locating outside of the working frequency band by carefully selecting the sizes of the cavity, for example by selecting  $W=4.2\text{mm}$ ,  $H=1.7\text{mm}$  and  $L>6.6\text{mm}$  (or  $L<6.2\text{mm}$ ) there will be no bad performance point in the frequency band 75GHz~77GHz (see Fig.6 (b)). To further eliminate the bad point, rhombus-like cavity which is helpful to avoid the resonant modes is proposed, see Fig.7, there also added a small rectangular cavity at the side of the rhombus-like cavity for setting auxiliary circuit, and the simulation results of different sizes of  $L$  are shown in Fig.8, it is evident that transmission parameters are better than that of the rectangular cavity.

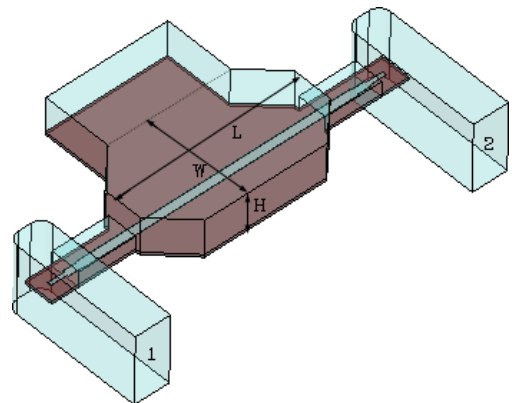

Fig.7 Rhombus-like cavity ( $W=4.2\text{mm}, H=1.7\text{mm}$ )

### III. CONCLUSION

A waveguide-based four-way power combining network is designed in this paper, the power combining network contains six waveguide directional couplers and four rhombus-like PCB cavities. The structure of the power combining network is simulated using HFSS 12, the transmission and reflection coefficients are satisfactory at the design frequency band. The required work frequency band is not so wide in this design, so the waveguide directional coupler can be designed in compact size with only one coupling slot, which surely confines the frequency bandwidth of the coupler and accordingly confines the bandwidth of the power combining network. In wide band system, the multi-coupling-slot waveguide directional coupler should be used to broaden the frequency bandwidth of the power combining network.

### ACKNOWLEDGMENT

This paper is supported by NSFC 61071046, NSFC 61101020.

Joint supported by Aeronautical Science Foundation and RF simulation Key Lab of Avionics System.

### REFERENCES

- [1] Kai Chang and Cheng Sun, "Millimeter-wave power-combining techniques," *IEEE Transaction on Microwave Theory and Techniques*, Vol.31, No.2, pp.91-107, 1983.
- [2] Ge J. X., Li S. F. and Chen Y. Y., "Millimeter wave quasi-optical power combiner," *Electronics Letters*, Vol.27, No.10, pp.880-882, 1991.
- [3] M. Kim, E. A. Sovero, J. B. Hacker, et al., "A 100-element HBT grid amplifier," *IEEE Transaction on Microwave Theory and Techniques*, Vol.41, No.10, pp.1762-1771, 1993.
- [4] Michael P. DeLisio and Robert A. York, "Quasi-Optical and Spatial Power Combining," *IEEE Transaction on Microwave Theory and Techniques*, Vol.50, No.3, pp.929-936, 2002.
- [5] M.F. Durkin, R. J. Eckstein, M. D. Mills, et al., "35-GHz active aperture," *IEEE MTT-S Int. Microwave Symp. Dig.*, Los Angeles, CA, pp.425-427, 1981.
- [6] J. W. Mink, "Quasi-optical power combining of solid-state millimeter-wave sources," *IEEE Transaction on Microwave Theory and Techniques*, Vol.34, No.2, pp.273-279, 1986.
- [7] Kaijun Song, Yong Fan, and Zongrui He, "Broadband Radial Waveguide Spatial Combiner," *IEEE Microwave and Wireless Components Letters*, Vol.18, No.2, pp.73-75, 2008.
- [8] Xiaoqiang Xie, Ruimin Xu, Rui Diao and Weigan Lin, "A New Millimeter-wave Multi-way Power Dividing/Combining Network Based on Waveguide-Microstrip E-plan Dual-Probe Structure," *Global Symposium on Millimeter Waves*, pp.127-159, 2008.
- [9] Danyu Wu, Xiaojuan Chen, Gaopeng Chen, Xinyu Liu, "Novel high efficiency broadband Ku band power combiner," *International Conference on Microwave and Millimeter Wave Technology*, pp. 258-261, 2010.
- [10] E.G. Wintucky, R.N. Simons, J.C. Freeman, C.T. Chevalier, A.J. Abraham, "High-efficiency three-way Ka-band waveguide unequal power combiner," *IET Microwaves, Antennas and Propagation*, Vol.6, No.11, pp. 1195-1199, 2012.
- [11] Kang Zhiyong, Chu Qingxin, Wu Qionsen, "A compact Ka-band broadband waveguide-based traveling-wave spatial power combiner with low loss symmetric coupling structure," *Progress in Electromagnetics Research Letters*, Vol.36, pp. 181-190, 2013.

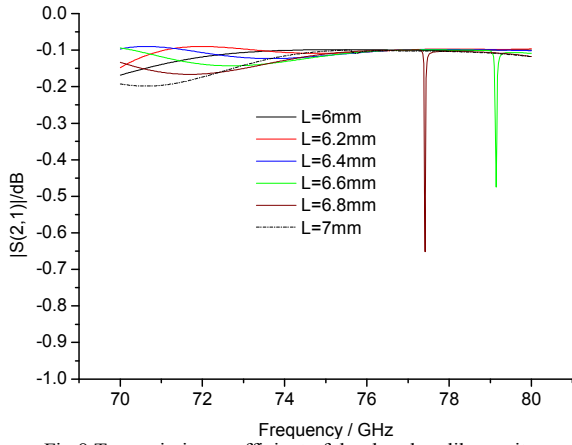

Fig.8 Transmission coefficient of the rhombus-like cavity

#### D. Structure of power combining network and simulated results

Finally, according the logic diagram in Fig.1, using the waveguide directional coupler in Fig.3 and the Rhombus-like cavity in Fig.7, the whole structure of the power combining network is obtained and shown in Fig.9, the connections between the waveguide directional couplers are carefully designed to reduce the size of the whole structure. Simulated results are shown in Fig.10, and the scattering parameters are good at the design frequency band.

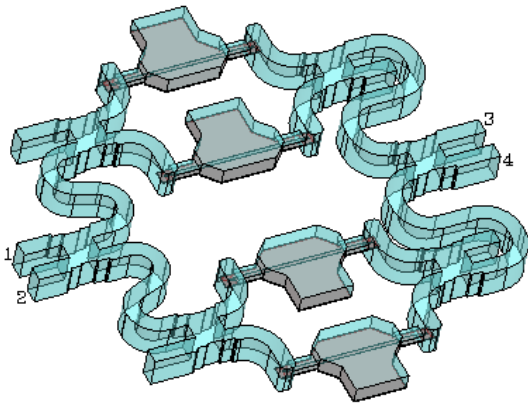

Fig.9 The power combining network

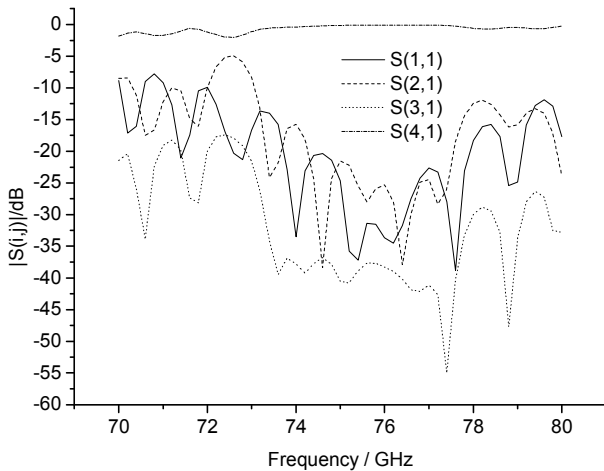

Fig.10 Simulated results of the power combining network