

A Planar Coaxial Collinear Antenna with Rectangular Coaxial Strip

Jiao Wang, Xueguan Liu, Xinmi Yang, Huiping Guo

School of Electronics and Information Engineering, Soochow University, Suzhou, China 215006

Abstract—A novel planar Coaxial Collinear (COCO) antenna with rectangular coaxial strip is presented. The planar COCO antenna is fed by microstrip and comprises several radiation sections of rectangular coaxial strips which are cross-linked one by one. A prototype has been designed and fabricated to cover the band of 2.4-2.48 GHz. The simulated and measured results show that the fractional -10 dB bandwidth of the prototype is 24.5%. With this band, the prototype possesses an omni-directional radiation pattern and achieves a gain of over 4 dBi in the direction of $\theta = 50^\circ$. The proposed antenna has characteristics of planar shape, compact size, wideband and easy fabrication. It is suitable for base station application of WiFi, RFID et al.

Index Terms—planar COCO antenna, cross-linked rectangular coaxial strips, planar antenna.

I. INTRODUCTION

Modern wireless communication is requiring antennas with low profile, light weight, compact size, easy integration with circuits, good consistency and accurate fabrication with mature process. Many traditional bulky antennas can't meet all these demands with respect to their heavy weight, large size or fabrication difficult. However, planar antennas can overcome all these shortcomings. Therefore, many researchers have made contribution to planarizing these bulky antennas in order to overcome the above shortcomings. For example, planar Archimedean spiral antenna [1], which demonstrates excellent axial ratio and gain-bandwidth performance in 2-18 GHz, is miniature and easy to fabricate. Hatem Rmili et al. [2] designed a compact and light printed dipole antenna, which can work in dual-band. A compact planar Yagi antenna used in portable RFID devices is described in [3]. Moreover, the famous Vivaldi antenna can also be regarded as the planarization of horn antenna [4]. All the above attempts to planarize traditional bulky antennas were successful and the related traditional antennas maintain satisfactory performance after planarization. And yet, planarization scheme of some other bulky antennas need to be further investigated. One example is coaxial collinear (COCO) antenna.

The classical COCO antenna was first proposed by B. B. Balsleyh and W. L. Ecklund [5]. It is composed of several segments of half-wavelength coaxial cables. The inner and outer conductors of the two adjacent cables are stagger connected. So that it makes the phase of one unit and the next unit same, and theoretically their amplitude is approximately same. The COCO antenna is widely used in radar and communication systems due to its low cost and structural simplicity. But it is time consuming to tune because of the complicated processing. What's more, the COCO antenna will encounter efficiency

degradation when its operation frequency exceeds 1 GHz and display a poor uniformity in electrical parameters. For this reason, it is meaningful to research on planar COCO antenna.

The conventional planar COCO antenna [6] consists of serially fed microstrip metallic patches that are alternately printed on the top and bottom surfaces of the substrate. In Ref. [7], a printed COCO antenna with balanced microstrip as its feed line and 8 back-to-back dipole arrays is presented. The bandwidth of both the antennas is limited. In this paper, a novel scheme for planarizing the traditional coaxial collinear (COCO) antenna, which can realize wideband, is proposed. In this scheme, crossed-linked rectangular coaxial sections are utilized as radiation elements and microstrip is used as feed line. A prototype of the novel planar COCO antenna has been designed and fabricated. The simulated and measured results of the prototype validate the proposed planarization scheme.

II. ANTENNA STRUCTURE

Fig. 1 depicts the geometry of the proposed antenna. It has four sections of rectangular coaxial strip, three connections and a feeding microstrip. Each section of rectangular coaxial strip is half wavelength ($\lambda_g/2$) long at central frequency 2.45 GHz. In consideration of fabrication, the antenna is composed of two layers of FR4 epoxy substrate, as shown in Fig. 1 (a) (b). The separated pieces of upper/lower ground attach to the upper/lower surface of the top/bottom substrate layer. The separated inner strips attach to the upper surface of the top substrate layer or the lower surface of the bottom substrate layer alternately. The antenna is fed by microstrip which occupies a small part of the bottom substrate layer. So the bottom substrate layer is longer than the upper one (Fig.1 (c)).

The adjacent sections of rectangular coaxial strip are stagger connected to each other as shown by Fig. 1 (c). As an example, Fig. 2 illustrates how the first two rectangular coaxial sections close to the microstrip feeding line are connected to each other. That is, the inner strip of the first section is connected to the end of the lower ground of the second section and the inner strip of the second section is connected to the end of the upper ground of the first section. Both connections are through via holes and the ground ends touching the via holes are cut by two symmetric triangles and hence exhibit gradual width. Fig. 1(a) (b) shows the geometries of the connection.

III. DESIGN PROCEDURE

In this section, we will describe the procedure for designing the planar COCO antenna in detail. Firstly, the planar elements

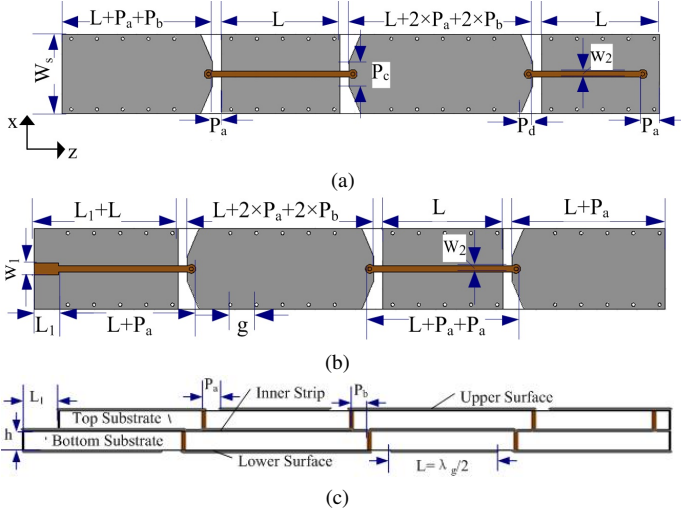

Fig. 1. Geometry of the proposed antenna. (a) Top View. (b) Bottom View. (c) Side view.

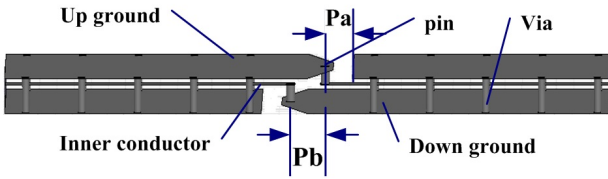

Fig. 2. Cross-linked rectangular coaxial sections.

of the proposed antenna are presented. Secondly, the cross-linked rectangular coaxial sections are designed and optimized. Finally, the dimensions of the antenna are optimized to obtain a good performance.

A. Design of Rectangular Coaxial Strip

The proposed planar element is rectangular coaxial strip. Rectangular coaxial strip can be regarded as the transformation of coaxial cable: just flatten the outer conductor of the coaxial cable, and make the inner conductor into flat strip line. By this way, coaxial can be planarized with rectangular coaxial strip.

Rectangular coaxial strip is shown in Fig. 3. According to the research in [8], when the width (w) of the flat inner conductor is less than one-quarter of the outer conductor's width, the expression for characteristic impedance should be the following:

where, ϵ_0 is permittivity of free space, ϵ_r is relative permittivity of substrate and c is velocity of propagation in free space.

In this paper, the 50Ω rectangular coaxial strip, the side walls of which are replaced by via holes in Fig. 2, is fabricated on two-layer FR4 epoxy substrate with relative permittivity of 4.4. Here we set the spacing (g) between the adjacent via holes as 6.5mm. According to (1), the dimensions b , h and w of the rectangular coaxial strip are set to 0.018 mm, 1.6 mm and 1.4 mm, respectively.

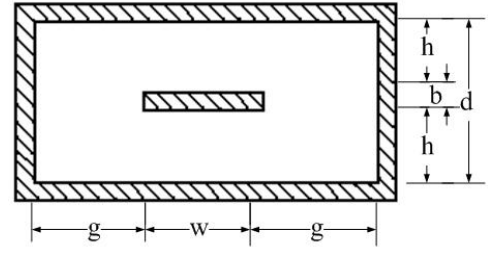

Fig. 3. Cross section of a rectangular coaxial strip.

B. Design of Cross-Linked Rectangular Coaxial Sections

A parametric study was carried out to find out the influence of certain geometries on antenna's impedance matching. The involving geometries include the spacing between a via hole and its neighboring isolated ground piece reside in the same substrate layer P_a , the spacing between the adjacent via holes P_b , the width and the length of the triangle cut from the ground end (P_c & P_d).

As observed from Fig. 4 (a) (b), neither P_b nor P_c has significant influence on the return loss of the proposed antenna. On contrast, P_d has remarkable influence on the return loss of the proposed antenna, as shown by Fig. 4 (c). An increase of P_d will results in a decrease of return loss. In our final design, P_b , P_c and P_d are optimized to 3 mm, 2 mm and 7 mm, respectively.

C. Antenna Discussion

As illustrated in Fig. 5, P_a has influence greatly over antenna performance. Firstly, the resonance frequency decreases as P_a increases (Fig. 5 (a)). Secondly, the antenna gain increases as P_a increases (Fig. 5 (b)). The final choice of P_a in our design is 3.8 mm.

The prototype antenna was optimized with full wave simulation solver HFSS, and then fabricated with two-layer FR4 epoxy substrate with dielectric constant of 4.4 and loss tangent of 0.02. Both layers are 1.6 mm high. Fig. 6 demonstrates the top and bottom view of the manufactured planar COCO antenna. The design parameters are $L=30$ mm, $W_s=20$ mm, $W_2=1.4$ mm, $P_a=3.8$ mm, $P_b=3$ mm, $P_c=2$ mm, $P_d=7$ mm, $g=6.5$ mm. The feeding microstrip which is designed to have a characteristic impedance of 50Ω is a 6 mm long and 2.8 mm wide strip. The radius of the pin is 0.5 mm. The overall size of the planar COCO antenna is $20 \times 157 \times 3.3mm^3$.

IV. RESULTS AND DISCUSSION

The prototype antenna was measured using Agilent vector network analyzer E5071B. Fig. 7 shows the simulated and measured reflection coefficients of the prototype. The measured resonance frequency is 2.48 GHz, while the simulated value is 2.43 GHz. The measured and simulated fractional -10 dB bandwidth is 24.5% and 12.4%, respectively. The discrepancy between the measured and the simulated results is mainly due to fabrication error and measurement error.

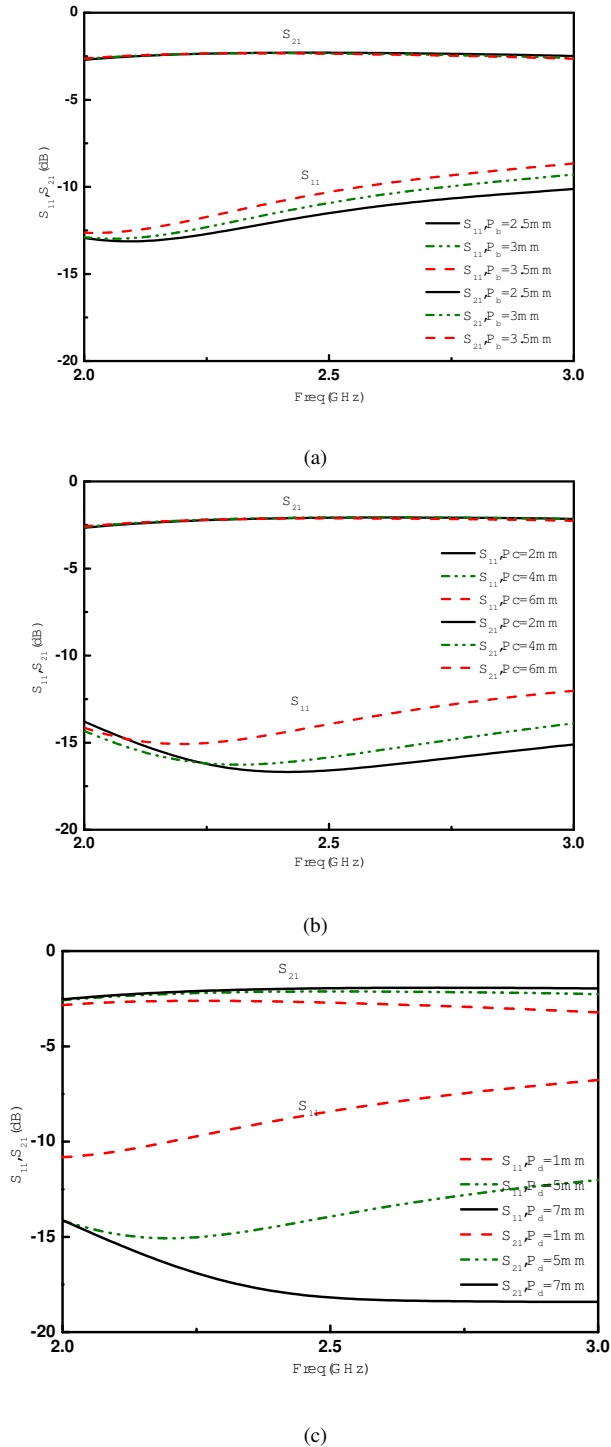

Fig. 4. Effects of varying the (a) P_b , (b) P_c , (c) P_d on the impedance matching.

Fig. 8 gives the simulated and measured radiation patterns of the planar COCO antenna. As shown by Fig. 8 (a), the radiation pattern is nearly symmetric with respect to z axis and the prototype antenna radiates nearly omni-directional in the directions with fixed angle. It is also found that the maximum radiation of the prototype antenna is about 50° off the z axis and hence the antenna is suitable for base station application.

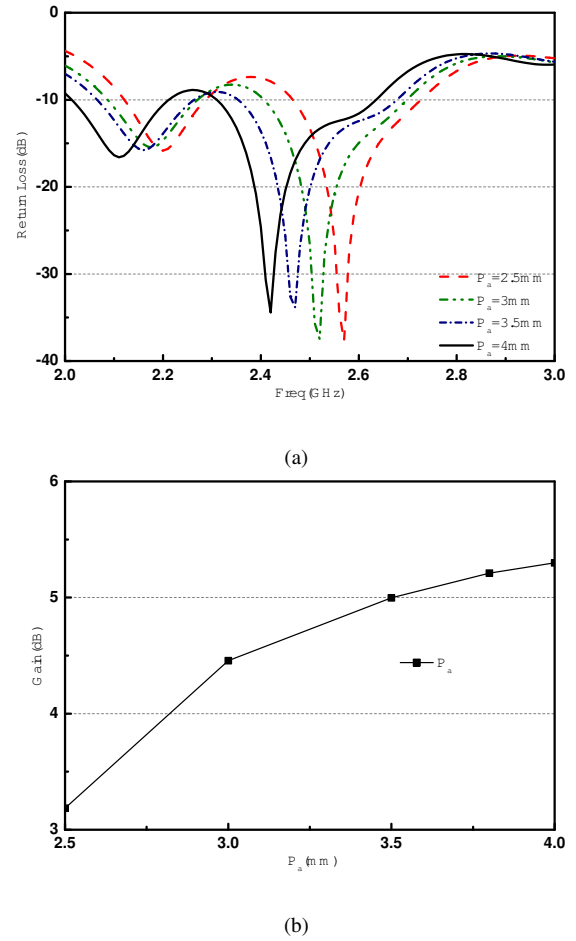

Fig. 5. (a) Effects of varying P_a on the antenna return loss. (b) Simulated gain of the prototype antenna.

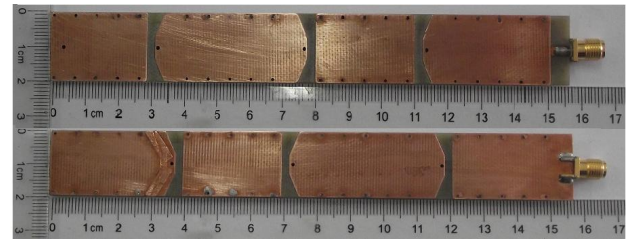

Fig. 6. Photograph of the proposed antenna.

A plot of the measured gain in the directions of $\theta = 50^\circ$ over the operational frequency band is illustrated in Fig. 9. It is found from this figure that the maximum measured gain of 5.06 dB is obtained at 2.44 GHz. For comparison, the simulated antenna gain at 2.45GHz is 5.29 dB. The simulated results are in good agreement with the measured results. As shown in Fig. 9 (b) (c), the radiation pattern in the direction of $\theta = 50^\circ$ at 2.4 GHz and 2.48 GHz are also omni-directional.

V. CONCLUSION

A novel compact planar COCO antenna with rectangular coaxial strip has been proposed. The antenna is composed of four cross-linked rectangular coaxial sections and a microstrip

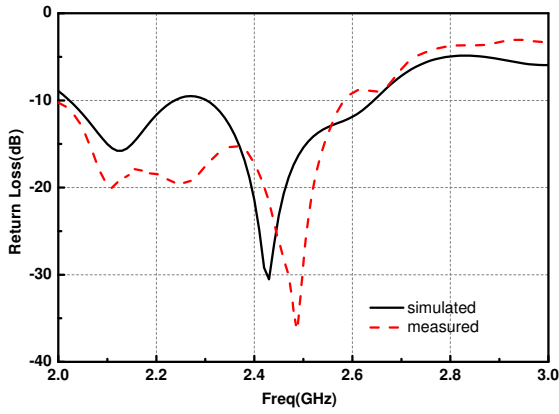

Fig. 7. Simulated and measured return losses of the prototype antenna.

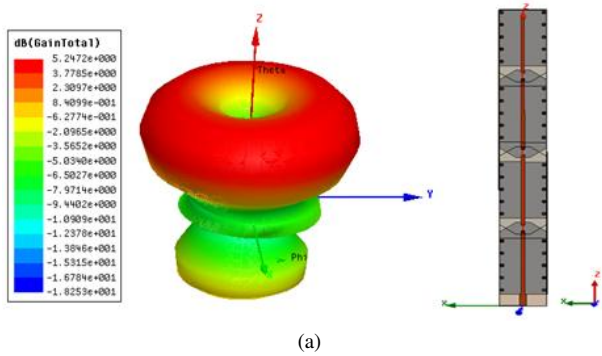

Fig. 8. (a) Simulated 3D radiation pattern at 2.45 GHz. (b) Simulated and measured radiation pattern with $\theta = 50^\circ$ at 2.45 GHz. (c) Simulated and measured radiation pattern in yoz plane at 2.45 GHz.

feed line. A prototype of the proposed antenna is designed and fabricated. The measured results show that the planar COCO antenna operates in the frequency band of 2.0-2.58 GHz and the gain in the band of 2.4GHz-2.48GHz ranges from 4.33 to 5.06 dB. The proposed antenna has the features of planar shape, compact size and easy fabrication. It is suitable for the base station application of WiFi, RFID et al.

ACKNOWLEDGMENT

This work was supported in Part by Suzhou Key Laboratory of RF and Microwave Millimeter Wave Technology, and in part by the Natural Science Foundation of the Higher Education Institutions of Jiangsu Province under Grant No. 12KJB510030. The authors would like to thank the staffs of the Jointed Radiation Test Center of Soochow University.

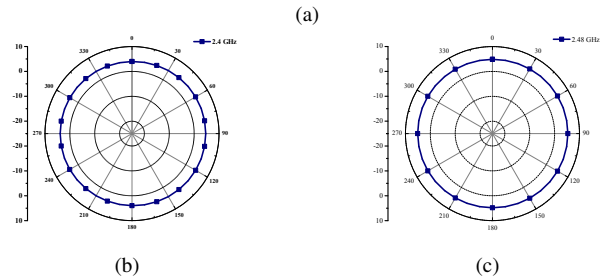
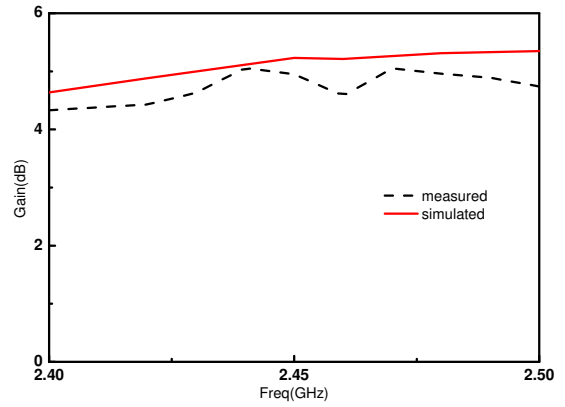

Fig. 9. (a) Simulated and measured gain of the prototype antenna. (b) Simulated radiation pattern with $\theta = 50^\circ$ at 2.4 GHz. (c) Simulated radiation pattern with $\theta = 50^\circ$ at 2.48 GHz.

REFERENCES

- [1] D. Berry, R. Malech, and W. Kennedy, "The reflectarray antenna," *Antennas and Propagation, IEEE Transactions on*, vol. 11, no. 6, pp. 645–651, 1963.
- [2] H. Rmili, J. Floc'h, P. Besnier, and M. Drissi, "A dual-band printed dipole antenna for imt-2000 and 5-ghz wlan applications," in *Wireless Technology, 2006. The 9th European Conference on*, 2006, pp. 4–7.
- [3] P. Nikitin and K. V. S. Rao, "Compact yagi antenna for handheld uhf rfid reader," in *Antennas and Propagation Society International Symposium (APSURSI), 2010 IEEE*, 2010, pp. 1–4.
- [4] P. J. Gibson, "The vivaldi aerial," in *Microwave Conference, 1979. 9th European*, 1979, pp. 101–105.
- [5] T. Judasz and B. Balsley, "Improved theoretical and experimental models for the coaxial colinear antenna," *Antennas and Propagation, IEEE Transactions on*, vol. 37, no. 3, pp. 289–296, 1989.
- [6] R. Hill, "A twin line omni-directional aerial configuration," in *Microwave Conference, 1978. 8th European*, 1978, pp. 307–311.
- [7] Y. Xiaole, N. Daning, and W. Wutu, "An omnidirectional high-gain antenna element for td-scdma base station," in *Antennas, Propagation EM Theory, 2006. ISAPE '06. 7th International Symposium on*, 2006, pp. 1–4.
- [8] T.-S. Chen, "Determination of the capacitance, inductance, and characteristic impedance of rectangular lines," *Microwave Theory and Techniques, IRE Transactions on*, vol. 8, no. 5, pp. 510–519, 1960.