

# Electric Field Measurement Close to Antennas at an Upper Frequency in the SHF Band

Kei SATOH<sup>†</sup> Teruo ONISHI<sup>†</sup> Ai-ichiro SASAKI<sup>‡</sup> Hiroki MORIMURA\* and Akihiko HIRATA<sup>‡</sup>

<sup>†</sup> Research Laboratories, NTT DOCOMO, INC., 3-6 Hikari-no-oka, Yokosuka, Kanagawa 239-8536 Japan

<sup>‡</sup> NTT Device Technology Labs, NTT Corporation, 3-1 Morinosato, Wakamiya, Atsugi-shi, Kanagawa 243-0198 Japan

\*NTT Device Technology Labs (Currently with NTT Device Innovation Center), NTT Corporation

E-mail: <sup>†</sup> {satoukei, oonishite}@nttdocomo.com

**Abstract** Since the next-generation mobile communication system, "5G (Fifth Generation)," requires more frequency bands to achieve ultra-high-speed communications, technical verification has been conducted above 6 GHz. However, there is no clear method for evaluating the electromagnetic exposure above 6 GHz. We present the first study comparing waveguide (WG) and electro-optic (EO) probes for use in an electric field distribution measurement method in the vicinity of super high frequency (SHF) band antennas. The results based on the EO probe measurements are closer to calculated results than those using the WG probe, which indicates that the EO probe is more effective in measuring the electric field strength of high SHF antennas.

**Keywords** 5G, Electric Fields Measurement, SHF Band, Electro-Optic probe, Wave-guide probe

## 1. Introduction

In order to create an ultra-advanced information society after 2020, research and development of the next-generation mobile communication system, "5G (Fifth Generation)," is in progress [1]. Since 5G requires more frequency bands to achieve ultra-high-speed communications, technical verification has been conducted above 6 GHz [2].

On the other hand, from the viewpoint of radio wave protection, according to radio protection guidelines [3], the power density shall be used to assess exposure above 6 GHz whereas the specific absorption rate (SAR) has been used for mobile terminals below 6 GHz. Therefore, discussion has arisen on the discontinuity of the allowable output power as a boundary to 6 GHz [4]. In addition, there is no definite method for evaluating the electromagnetic exposure above 6 GHz.

In this paper, we present the first study aimed at establishing an electric field distribution measurement method in the vicinity of super high frequency (SHF) band antennas. We evaluate waveguide (WG) and electro-optic (EO) probes in measure the electric field strength of the high SHF antennas [5].

## 2. Measurements

Figures 1 and 2 are a schematic of an electric field distribution measurement system and a photograph of an experimental configuration for the electric field distribution measurement, respectively.

A standard-gain horn antenna is used as the

radiation source. An EO probe with a 3-mm square electric field detector made of zinc telluride (ZnTe) and a WG probe are used. The frequency to be evaluated is 15 GHz, which is one of the candidate frequency bands for 5G.

The electric field strength is measured in 1 mm intervals at the distance from the antenna aperture of 15 mm. The input power toward the radiating source is 22 dBm.

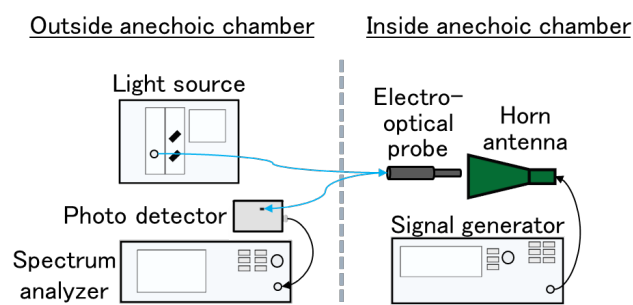
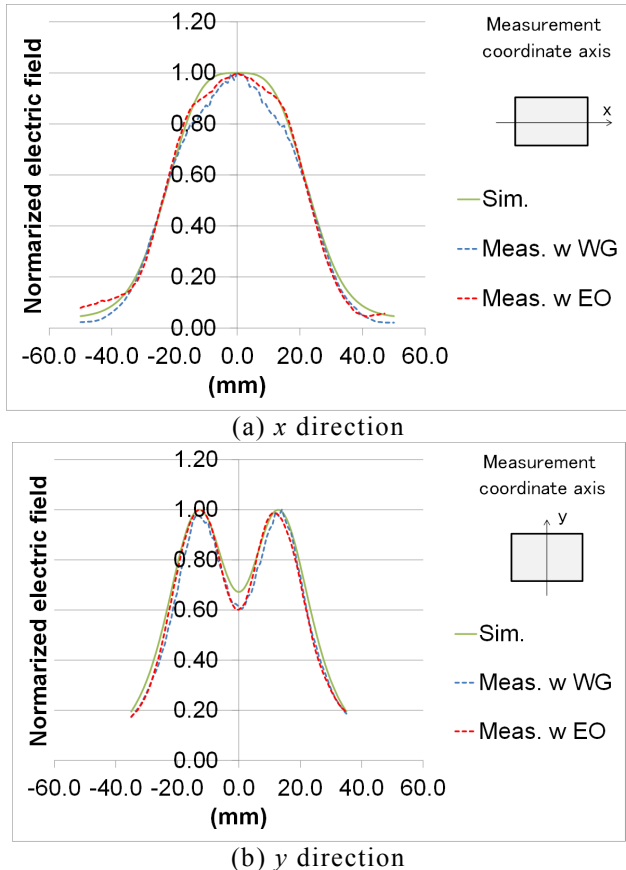

Fig. 1 Schematic of electric field distribution measurement system.



Fig. 2 Experimental configuration for electric field distribution measurement.



**Fig. 3** Electric field distribution measurement results compared to electromagnetic simulation results.

### 3. Measurements Results

Figures 3(a) and 3(b) show a comparison of the measured electric field distribution results and simulation results. These graphs show the normalized electric field strength versus the distance from the aperture of the center of the standard-gain horn antenna. The Finite-Difference Time-Domain (FDTD) method is used as the numerical simulation method.

The tendency of the electric field distribution of the EO probe and that for the WG probe are roughly consistent with those obtained through simulation. The measured strength using the WG and EO probes becomes maximum at 0 mm in the  $x$  direction of the standard-gain horn antenna, and approximately  $\pm 13$  mm in the  $y$  direction of the standard-gain horn antenna.

However, the measured distributions using the EO and WG probes differ from the simulated ones within  $\pm 20$  mm from the aperture of the center in the  $x$  and  $y$  directions of the antenna. In particular, the difference between the simulated and measured electric fields using the WG probe is greater than the difference between the simulated and measured results using the EO probe. Furthermore, the electric field distribution

using the WG probe is not smooth. The reason why the measured electric field distributions using the EO probe are closer to the simulated ones than those using the WG probe is that the EO probe comprises a non-metallic electric field detector that hardly disturbs the electromagnetic field and loosely couples with the radiation source.

### 4. Conclusion

As the first step in determining a suitable method for measuring the electric field close to antennas used in an upper frequency in the SHF band, we measured the electric field distribution close to a 15-GHz band standard-gain horn antenna using the WG and the EO probes. While both showed generally good agreement with the calculated results, the measured results using the EO probe are closer to the calculated results than those using the WG probe. Our next research target is to investigate the measurement method in detail including higher frequencies.

### References

- [1] DOCOMO 5G White Paper, July 2014. [https://www.nttdocomo.co.jp/english/binary/pdf/corporate/technology/whitepaper\\_5g/DOCOMO\\_5G\\_White\\_Paper.pdf](https://www.nttdocomo.co.jp/english/binary/pdf/corporate/technology/whitepaper_5g/DOCOMO_5G_White_Paper.pdf)
- [2] Press Release, "DOCOMO's 5G Outdoor Trial Achieves 4.5Gbps Ultra-high-speed Transmission," [https://www.nttdocomo.co.jp/english/info/media\\_center/pr/2015/0302\\_03.html](https://www.nttdocomo.co.jp/english/info/media_center/pr/2015/0302_03.html), March 2015.
- [3] The radio wave protection guideline. <http://www.tele.soumu.go.jp/resource/j/material/dwn/guide38.pdf> (in Japanese).
- [4] D. Colombi, B. Thors, and C. Törnevik, "Implications of EMF exposure limits on output power levels for 5G devices above 6 GHz," *IEEE Antennas and Propag. Lett.* vol. 14, pp. 1247-1249, June 2015.
- [5] T. Nagatsuma and S. Hisatake, "Trends in electromagnetic-wave measurement technologies using electro-optic effect," *IEICE Trans. Electron.*, vol. J97-B, No. 3, pp. 243-252, March 2014 (in Japanese).