

# W-Band Wireless Access Systems using RoF Technologies — Toward Resilient Seamless Access Network —

Nobuhiko SHIBAGAKI

Hitachi, Ltd.

Nihonbashi First Bldg., 1-2-19, Nihonbashi, Chuo-ku, Tokyo, 103-0027, Japan

E-mail: nobuhiko.shibagaki.qr@hitachi.com

**Abstract** W-band wireless access systems using millimeter-wave RoF technologies are developed in the frequency range of 90-100 GHz. A data transmission of 10 Gbps using 16QAM has been successfully demonstrated using W-band RF and optical components. The W-band wireless link can provide a backup link of high-speed optical data link.

**Keywords** Radio over Fiber (RoF), W-band, Wireless access system

## 1. Introduction

The optical fiber access systems can provide high-speed data transmission using simple modulation formats, such as on-off-keying (OOK), binary phase-shift-keying (BPSK) to the subscriber terminals, while it is difficult for the optical devices to apply the multi-level quadrature amplitude modulation (QAM) method due to a lack of precise control of optical device characteristics. However, the digital coherent optical communication technologies based on high-performance digital signal processing (DSP) and vector optical modulation/demodulation have been developed to transmit high-speed data transmission.

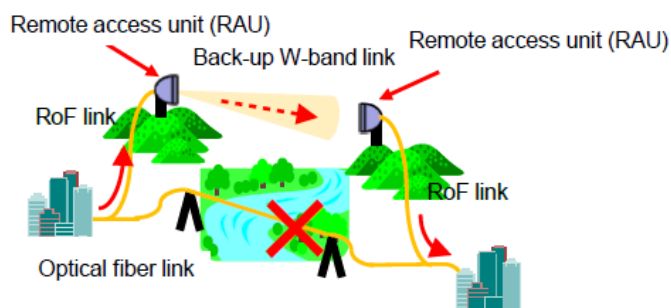
The other potential technology to transmit the multi-level QAM format through the optical fiber cables is known as Radio over Fiber (RoF) technologies which can directly send and/or receive the radio waveform. The advantage of the RoF link is a simplification of Radio Access Unit (RAU) which interfaces the optical cables and the air. The maximum data speed is limited by the modulation/demodulation methods which are commonly used for the wireless communication systems, but not limited by the precise control of the optical device. The high-speed data transmission over 10Gbps through W-band RoF links can be feasible using the current modulation/demodulation method, because the W-bands have a larger bandwidth than microwaves.

This paper proposes the parallel connection of the optical fiber and RoF links to provide flexible operation of telecommunication services. If the optical fiber link is disconnected by the disaster or accident, the W-band RoF link can operate as a backup of the optical fiber link to immediately recover the disconnected communication link. The backup link consists of the W-band RAU and the wireless links. The above mentioned RAU interfaces the RoF link with the wireless link. This paper also

proposes the W-band RF technologies for designing the fixed wireless access link using the W-band RAU.

## 2. W-band System Architecture

Radio communication systems can provide agile deployment capability, especially in particular locations such as mountains, valleys and rivers. Figure 1 shows a schematic concept of the seamless connections of optical and W-band wireless links. The W-band wireless link can be used as a backup, when the wired link is disconnected by disaster, accident, etc. The average data rate of the conventional wireless link is around a few Gbps, while the optical fiber communication can offer over 100 Gbps data transfer. Therefore, higher data rate of the wireless link are required to mitigate surge of traffic demands in particular cases including disaster recovery phases. The W-band is more attractive for high-speed data transmission rather than microwave bands, because the broader frequency ranges over 5 GHz are available [1]. In terms of atmospheric attenuation, the use of W-band (75–110 GHz) transmission appears to be suitable, as the attenuation within this band tends to be less than 1 dB/km, as shown in Figure 2. However, the attenuation increases largely under heavy rain conditions which limits the transmission length of the wireless link [2].



**Fig. 1** Application of W-band wireless link to backup of optical link.

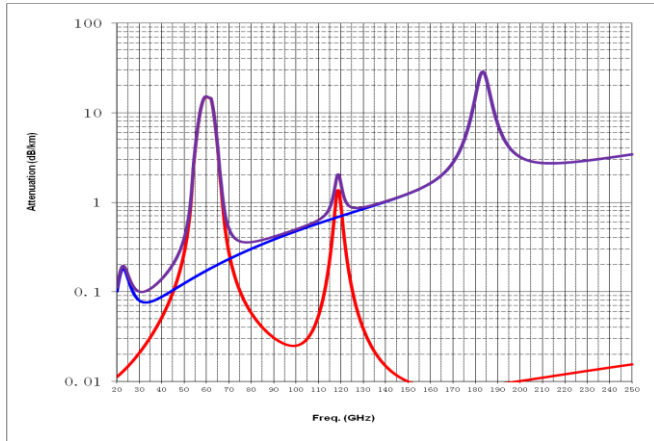


Fig. 2 Attenuation characteristics vs. frequency [3].

### 3. W-Band Spectrum Issue for Fixed Wireless Access

The frequency of 26 GHz band, 28 GHz band and 32 GHz bands are densely used for Point-to-Point (PtP) and Point-to-MultiPoint (PtMP) systems. V-band (57 to 64, 64 to 66 GHz) is also expected to play a key role for the backhaul of small cells for mobile systems. E-band (71 to 76, 81 to 86 GHz) was introduced to transmit a few Gbps data over few kilometers and used for mainly PtP systems which are capable of transmission over a few Gbps data rate.

W-band (92 to 94 GHz) does not provide a larger contiguous bandwidth, if the other bands (94.1 to 100 GHz and 102 to 109.5 GHz) are not used. As shown in Table 1, although it is not contiguous band, a total bandwidth of 15.4 GHz which is larger than E-band is available for fixed, mobile and radio astronomy services as a primary. The administrations are urged to take all practicable steps to protect the radio astronomy service from harmful interference in accordance with RR no. 5.149 referencing Recommendation ITU-R RA.769-2[4].

Table 1 Frequency allocation for fixed service.

|                 |                       |
|-----------------|-----------------------|
| 92-94 GHz       | FIXED, MOBILE, Others |
| 94-94.1 GHz     | Not allocated         |
| 94.1-100 GHz    | FIXED, MOBILE, Others |
| 100-102 GHz     | Not allocated         |
| 102-109.5 GHz   | FIXED, MOBILE, Others |
| 109.5-111.8 GHz | Not allocated         |

### 4. W-band Radio Access Unit

#### A. Characteristics of RF components

Table 2 summarizes system specifications of W-band radio access unit. These parameters are achieved using GaAs monolithic integrated circuits, high gain antenna, broadband mixer, demultiplexer and optical components..

Table 2 System specifications

|                              |                    |
|------------------------------|--------------------|
| Frequency Range              | W-band             |
| Center Frequency             | 96 GHz             |
| Transmitting radiation power | 20 dBm             |
| E.I.R.P.                     | 6.6 W              |
| Maximum data rate            | 10 Gbps            |
| Transmission distance        | 1 km               |
| Modulation format            | QPSK, 16QAM, etc.  |
| Transceiver size             | 450 x 160 x 180 mm |
| Transceiver weight           | < 10 kg            |

Figure 3 shows a block diagram of W-band radio access unit which interfaces RoF link with W-band wireless link. The transmitter (Tx unit) consists of a multiplier (MP), amplifiers and an up-converter. The IF signals are up-converted by a broadband up-converter to W-band signals. The LO signal of the receiver is also supplied from the central station through an optical fiber. It is also multiplied by a multiplier and then supplied to a mixer to down-convert the received W-band signals to IF signals (Rx unit). The IF signals are then connected to an optical modulator. Figures 4 and 5 show external views of Tx and Rx units and W-band radio access unit, respectively. The size of Tx and Rx units is 50mm×50mm×12mm.

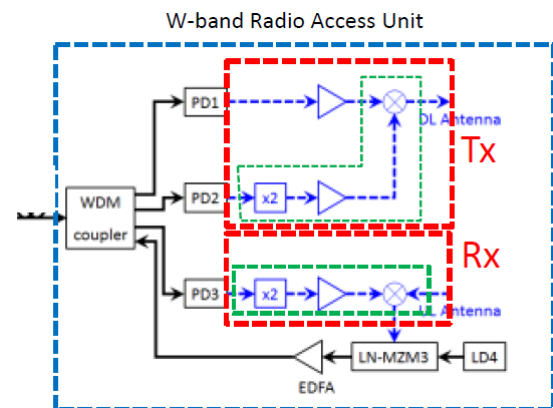


Figure 3 Block diagram of W-band radio access unit.



Tx unit

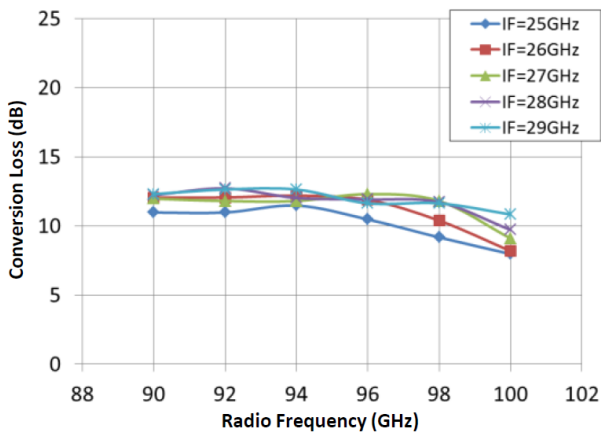
Rx unit

Figure 4 External view of Tx and Rx units.

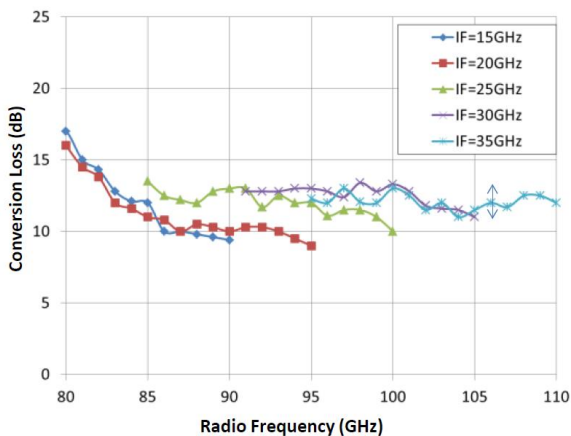


Figure 5 External view of W-band radio access unit.

Figure 6 shows the frequency responses of the up-converter and mixer. The conversion loss of the up-converter is 9-13 dB at the frequency range of 90-100 GHz, and that of the mixer 11-13 dB. The intermediate frequency (IF) to achieve such conversion loss of each component was in the frequency range of 26-28GHz and 25-30GHz, respectively.



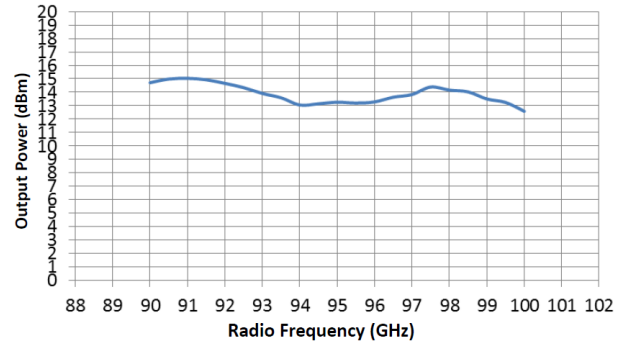
(a) Conversion loss of up-converter



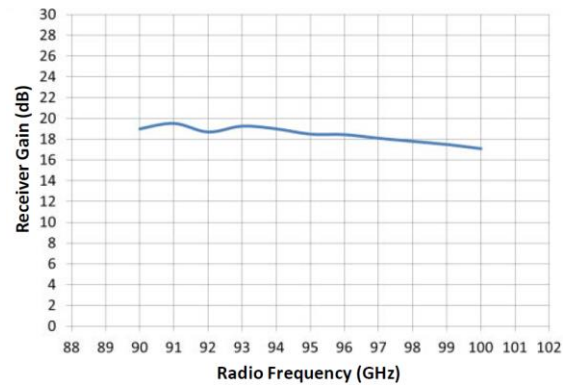
(b) Conversion loss of mixer

Figure 6 Frequency response of RF components.

Figure 7 shows the output power of Tx unit and the receiver gain of Rx unit in the frequency range of 90-100 GHz. The output power of 12-15 dBm was achieved at IF frequency of 25 GHz and IF input power of 0 dBm in the condition of LO frequency range of 65-75 GHz and LO input power of 0 dBm. The receiver gain of 17-20 dB was achieved at RF input power of -40 dBm and IF frequency of 25 GHz in the condition of LO frequency range of 65-75 GHz and LO input power of 0 dBm.



(a) Output power of Tx unit.



(b) Receiver gain of Rx unit.

Figure 6 Frequency responses of Tx and Rx units.

### B. Data transmission characteristics

The overall data transmission characteristics were evaluated using a symbol rate of 2.5 Gbps. Bit rate of QPSK and 16QAM modulated signals are 5 Gbps and 10 Gbps, respectively. Table 3 and 4 show EVM value obtained when QPSK and 16QAM signals are transmitted through Tx and Rx units.

Table 3 EVM of QPSK signal vs input power of Rx unit.

| -60dBm | -55dBm | -50dBm | -45dBm | -40dBm | -35dBm |
|--------|--------|--------|--------|--------|--------|
| 17.9%  | 14.5%  | 11.4%  | 9.6%   | 9.4%   | 9.8%   |

Table 4 EVM of 16QAM signal vs input power of Rx unit.

| -60dBm | -55dBm | -50dBm | -45dBm | -40dBm | -35dBm |
|--------|--------|--------|--------|--------|--------|
| 21.3%  | 17.1%  | 12.9%  | 11.4%  | 10.6%  | 10.8%  |

Figure 8 shows constellation and spectrum of QPSK, 16QAM, 32QAM and 64QAM modulated

signals. Although the constellations of 32QAM and 64QAM are degraded by the total RF performance, 10Gbps signal transmission using 16QMA was accomplished by the RF components describes above section.

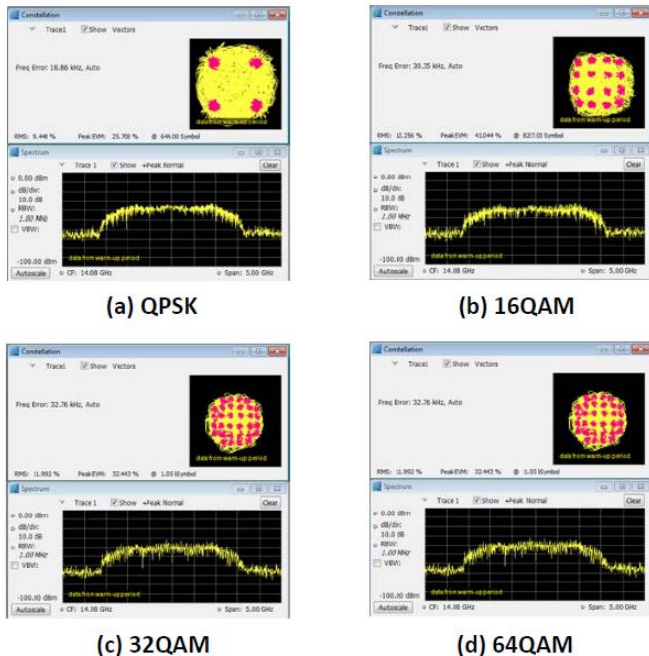


Figure 8 Performance of constellation and spectrum.

### 5. Conclusion

The concept of seamless connections of wired link and wireless link consisting of W-band wireless and RoF links is proposed. The configuration and performance of the W-band radio access unit which interfaces the RoF link with the W-band wireless link has been introduced. The W-band wireless link can provide high-speed data transmission links which are useful for backup of optical fiber links. The W-band is very attractive frequency ranges to transmit the data rate over 10 Gbps.

### Acknowledgments

The research results have been achieved by “Agile Deployment Capability of Highly Resilient Optical and Radio Seamless Communication Systems,” the commissioned research of National Institute of Information and Communications Technology (NICT).

### References

- [1] N. Kamiya, et al.,” Study on Signal Modulation Schemes for Millimeter-Wave Band RoF Transmission Systems with Optical Signal Re-Modulation”, Proc. International Topical meeting on Microwave Photonics, pp. 58-61, Oct.2014..
- [2] Recommendation ITU-R P.676-9, “Attenuation by atmospheric gases”.
- [3] Renato Lombardi, “ISG mWT view on the allocation of spectrum for backhaul and front-haul”, ITU-R WP5C Millimeter-wave Workshop, July 2015.
- [4] Recommendation ITU-R RA.769-2, “Protection criteria used for radio astronomical measurements”.