

磁気結合型共振器によるワイヤレス給電システムの設計・製作

栗井郁雄、石田哲也、杉山一聖
龍谷大学理工学部

Abstract: A wireless power transfer system based on magnetically coupled two resonators is analysed using the filter theory. Design equations for each lumped parameter circuit components are derived. As a result, change of coupling coefficient between the resonators and/or change of load resistance are easily responded. Effect of circuit loss to the design theory is also addressed. After designing a power transfer system, a real system is constructed using spiral and loop coils. Dependence of circuit elements on their dimensions is measured in advance and used to cope with the designed element values. Simulated response by use of designed element values and measured result are compared, indicating the validity of the theory.

Key Words : BPF design theory, Magnetically coupled resonators, Simulation and experiment, System design, Wireless power transfer.

I . Introduction

After MIT group has proposed a resonator-coupled wireless power transfer (WPT) system [1], many people in the world have tried to confirm and/or improve the transfer property of the similar system. But partly because their theory is based on the intricate coupled mode theory and, in addition, all the necessary information does not seem to be disclosed, there is no design theory presented so far to our knowledge.

Considering that they use two coupled resonators facing each other and try to match them with the external circuits, their system is neither more nor less than a 2-stage band pass filter. Since the design theory of a BPF is well established [2], its modification is expected to give a simple and clear design theory of the wireless power transfer system [3],[4].

Since the BPF design is built for LCR circuits, our theory gives the relation of each circuit element. Thus, one has to find the equivalent circuit of the system first,

and then the dependence of each element value on their dimensions beforehand. Using the designed element value and the dependence above, one can determine the structure of the system.

We will take the MIT system as an example. But the theory can be applied for any magnetically coupled resonator system, and could be extended to electrically coupled systems easily. Some design examples will be shown together with the simulated response and the experimental results. Their reasonable agreement verifies the effectiveness of the design theory.

II . Equivalent Circuit

The rough sketch of MIT system is depicted in Fig.1. The coupling between the loop and spiral coils and also between two spiral coils is substantially magnetic, and thus, the coupling circuit should be expressed by mutual inductance circuit. In Fig.2, an equivalent circuit of the power transfer system in Fig. 1 is described, but it is a little too complicated to analyse.

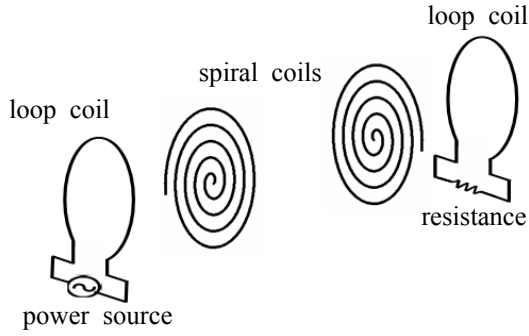

Fig.1 Wireless power transfer system based on magnetically coupled two resonators

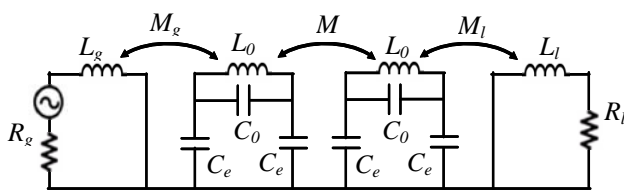

Fig. 2 Equivalent circuit of Fig. 1

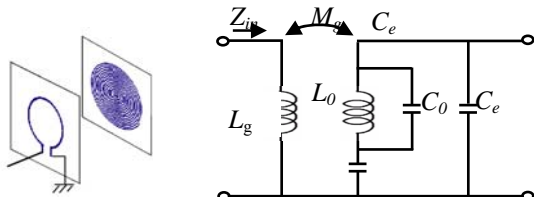

Fig. 3 Equivalent circuit of a loop coil coupled to a spiral coil

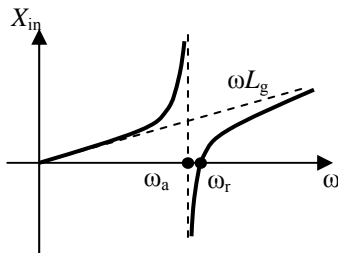

Fig. 4 Frequency characteristic of input reactance of circuit in Fig. 3

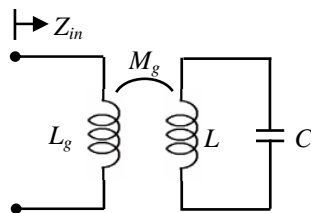

Fig. 5 Simplified equivalent circuit of a loop coil coupled to a spiral coil and its input impedance

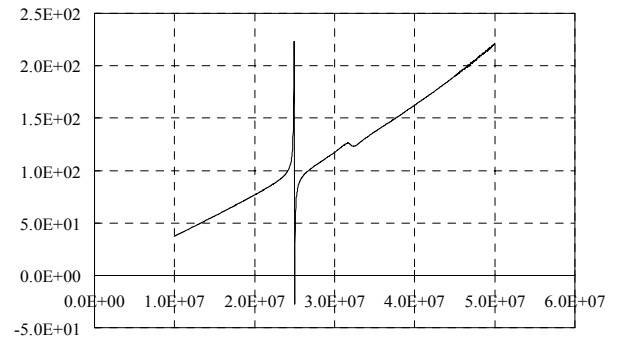

Fig. 6 Typical frequency characteristic of input reactance of loop coil coupled to spiral coil (measured result)

In order to simplify it, we will calculate the input impedance of the loop coil coupled to a spiral coil as shown in the inset of Fig. 3. The input reactance is obtained to show the series and parallel resonances as depicted in Fig. 4.

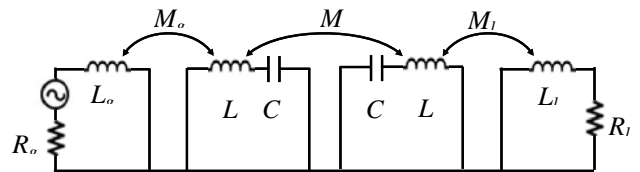

Fig.7 Equivalent circuit of power transfer system

Considering that the capacitances connecting to the inductance L_0 in Fig. 3 could be reduced to one, we calculate the input impedance of the circuit in Fig. 5. It turned out to show the similar frequency characteristics as shown in Fig. 4. To confirm the process above, we have measured a typical loop coil coupled to a spiral coil that has the configuration shown in Fig. 3. The obtained frequency characteristic in Fig. 6 shows the same behaviour as Fig. 4, and hence, the simplified circuit in Fig. 5 has turned out to be safely adopted for the equivalent circuit representation of the system in Fig. 1. We will utilize Fig. 7 as the equivalent circuit to design the WPT system shown in Fig. 1.

III. Condition for 2-stage BPF

Since Fig. 7 represent a typical 2-stage bandpass filter made of two inductively coupled resonators, the standard circuit transformation and the requirement for a matched BPF condition claim the following relations between the circuit parameters [4],[5].

$$M_g = \sqrt{(1+Q_{eg}^2) \frac{R_g}{\omega_r}} M \quad (1)$$

$$\frac{M_\ell}{M_g} = \sqrt{\frac{R_\ell}{R_g}} \quad (2)$$

$$\frac{L_\ell}{L_g} = \frac{R_\ell}{R_g} \quad (3)$$

$$C' = \frac{C}{1 - \frac{Q_{eg}^2 k_g^2}{1 + Q_{eg}^2}} \quad (4)$$

where k_g is the coupling coefficient between the loop and spiral coils at the generator side, and Q_{eg} is the external Q of the loop coil at the generator side, too.

$$k_g = \frac{M_g}{\sqrt{L_g L}} \quad (5)$$

$$Q_{eg} = \frac{\omega_r L_g}{R_g} \quad (6)$$

Now, let us consider how the design of power transfer system is carried out. First, the input resistance of the generator R_g is given. The key component of system is probably the spiral coil, since it determines the outreach of power transfer as well as the transfer efficiency. Then the parameters L and C are determined first (since there is no need to have different values for two spiral coils, they are assumed the same). The mutual inductance M (or coupling coefficient k) is affected by the distance between coils, and hence, is suspended to decide.

The loop coils are used to attain the circuit matching. They can be slid to change the coupling to the spiral coil. In that usage, the self inductance L_g and L_ℓ will be given because one has to prepare the coils first. In summary, we give the parameter L , C , and R_g first, and then, L_g and L_ℓ . The tuneable parameters should be the mutual inductance of spiral coils M , the load resistance R_ℓ , and the mutual inductances M_g and M_ℓ .

Equation (4) indicates that the capacitance C of the spiral coil should be adjusted in order to keep the center frequency of the BPF as designed at the beginning. It happened because the spiral coil is influenced by the loop coil coupled with the external circuit.

When the coupling between two spiral coils changes, M_g should be adjusted according to eq. (1) together with M_ℓ , being related with M_g as shown in eq. (2). But the self inductance of loop coil is allowed to be constant. It means that the change of distance between two spiral coils is responded only by adjusting the distance between the spiral and loop coils.

If the load resistance R_ℓ changes, both the self inductance and mutual inductance of the load loop coil should be adjusted due to eqs. (2) and (3). In order for the self inductance to be changed, the coil itself should be deformed. But for the mutual inductance, only the distance to the spiral coil can be adjusted. There is no influence to the two spiral coils.

These characteristics above have never presented though each one can be half expected. The clearly-stated relations, eqs. (1) to (6) will help design the magnetically coupled power transfer system.

IV. Dependence of Circuit elements on Their Dimensions

In order to construct a WPT system, one needs to prepare the parametric dependence of each circuit

element. It could be obtained either by E/M simulation or experiment. We will take experiment, since the simulation of coils takes too much CPU time.

In construction of the system, one should determine the kind of resonators. We will take spiral resonators with a certain pitch. Then, the operating frequency is to be determined, which gives the inductance L and the effective capacitance C in Fig. 7. The inductance of the fabricated spiral coil is measured with an LC meter at a low frequency, e. g. 100 kHz, and the capacitance is calculated by the relation

$$LC = \frac{1}{\omega_r^2} \quad (7)$$

, since it can not be measured directly.

Next, we have to decide the distance between two spiral coils. The decision could be made according to various standards such as

- (1) distance itself
- (2) transfer loss
- (3) frequency tolerance of the source

These quantities somewhat contradict each other, and thus, there should be a judgment for the priority.

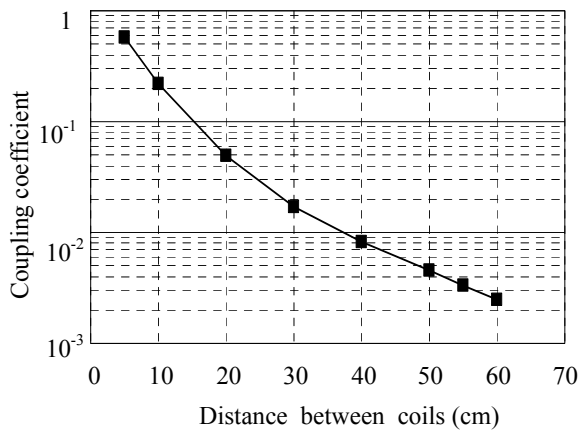

Fig. 8 Coupling coefficient of spiral coils (Pitch; 1cm, Diameter; 25.5cm, f_r ; 25MHz)

In Fig. 8, a measured coupling coefficient as a function of the coil distance is shown, where we choose the distance, then the coupling coefficient k is decided. The measurement is carried out using a vector network analyzer. Two sets of spiral and loop coils as shown in Fig. 3 is faced each other, and S_{21} is measured that has two resonant peaks f_1, f_2 due to mutual

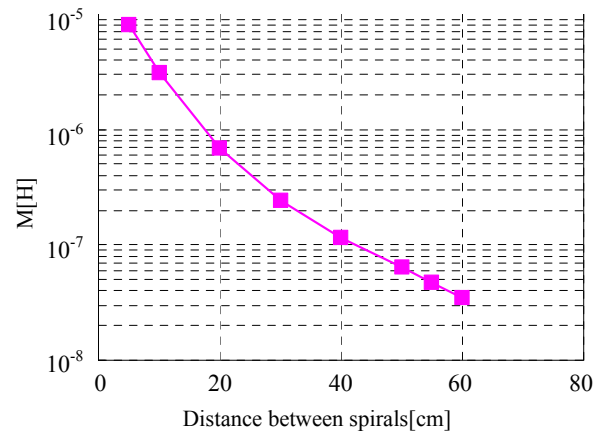

Fig. 9 Mutual inductance of spiral coils

coupling. The coupling coefficient k is calculated by the relation

$$k = \frac{f_2^2 - f_1^2}{f_2^2 + f_1^2} \quad (8)$$

Furthermore, from the relation

$$k = \frac{M}{\sqrt{L_1 L_2}} \quad (9)$$

, and Fig. 8, one can find the mutual inductance of two spiral coils as a function of the coil spacing as shown in Fig. 9.

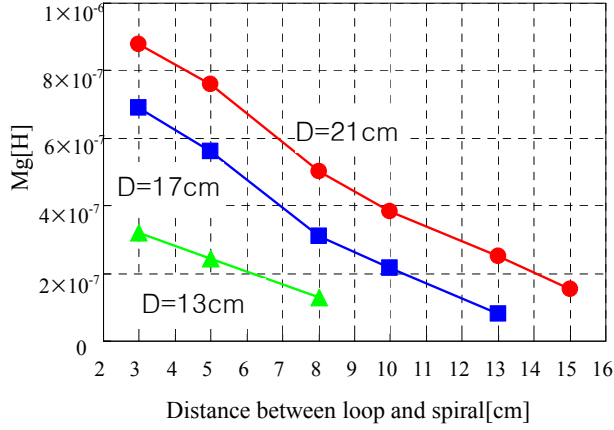

Fig. 10 Mutual inductance between loop and spiral coils (D is diameter of coil)

In the next, we will move on to the loop coil. The self inductance of loop coil is measured with an LC meter in the same way as the spiral coil. But the mutual inductance between a loop and spiral coils needs a small elaboration. For the circuit in Fig. 5, the input impedance Z_{in} is given as

$$Z_{in} = j\omega L_g \frac{1 - (\omega/\omega_r)^2}{1 - (\omega/\omega_a)^2} \quad (10)$$

, where

$$\omega_r^2 = \frac{1}{LC(1 - M_g^2/LL_g)} \quad (11)$$

$$\omega_a^2 = \frac{1}{LC} \quad (12)$$

Hence, M_g is calculated by the relation

$$M_g = \frac{1 - (\omega_a/\omega_r)^2}{\sqrt{LL_g}} \quad (13)$$

, since L and L_g are known, while ω_r and ω_a are measured from the input impedance for the structure shown in the inset of Fig. 3 using a VNA. The result is

described in Fig. 10 for three different loop diameters. The mutual inductance increases as the loop diameter increases as long as it is less than that of the spiral coil.

V. System Design and Measurement

We will design, simulate, construct and measure 2 systems with different distances between the spiral coils. Though the system with different source and load impedances is also quite important, we will not construct it this time, because the VNA with 50Ω input impedance can not cope with the system with different impedance easily.

We have chosen a spiral coil of 1 cm pitch. Winding it from the center, the diameter ended up with 25.5cm to have the resonant frequency 25 MHz. The measured inductance L was 14.0 H. Calculation with eq. (7) and measured inductance gives 2.90 pF for the effective capacitance C .

First example takes the distance between spiral coils as 30 cm, and then, the coupling coefficient is 0.017 consulting with Fig. 8. The mutual inductance M is known by Fig. 9 as 0.248 H. Since the loop coil at the source side can be chosen freely, we wound a one-turn loop with the diameter 21cm. The measured inductance is 0.80 H. Though the loop coil at the load side should be determined by use of eq. (3), it is taken the same as that for the source side, because we are adopting the same impedance 50Ω for the source and load.

The mutual inductance between the spiral and loop coils is to be calculated and the distance between both coils is to be obtained. The calculation is carried out by eqs. (1) and (2) to obtain 0.759 H for both coils while it is used to obtain the distance 5.0 cm between the coils, consulting with Fig. 10. The results are summarized in Table 1 and Fig. 11.

All the values obtained above for the circuit elements are used for the circuit simulation, and give

the frequency response shown in Fig. 12. The experimental result for the configuration in Fig. 11 is also shown in the same figure.

Table 1 Circuit parameters for designed system

(a) Given parameters (b) Calculated parameters

f_r	2.50E+07 Hz	C	2.90E-12 F
R_g	50 Ω	M	2.48E-07 H
R_l	50 Ω	Q_{eg}	2.51
L	1.40E-05 H	M_g	7.59E-07 H
k	0.0177	k_g	0.227
L_g	8.00E-07 H	L_l	8.00E-07 H
		M_l	7.59E-07 H

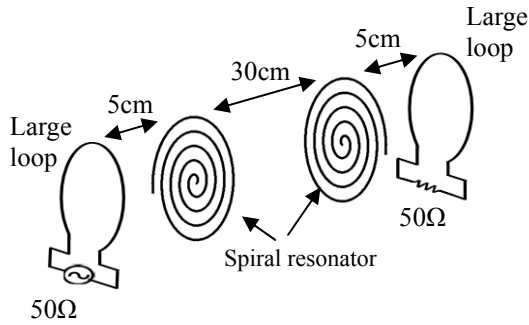

Fig. 11 Configuration of designed system

There are two differences between the simulated and measured results. First, the measured bandwidth is about 2/3 of simulation. It is probably because the coupling between the spiral coils is not purely magnetic, but includes the electric component. The simulation that assumes purely magnetic coupling should overestimate the coupling coefficient, resulting in a larger bandwidth. Secondly, there is an attenuation pole for the measured result, which is not known why at this moment.

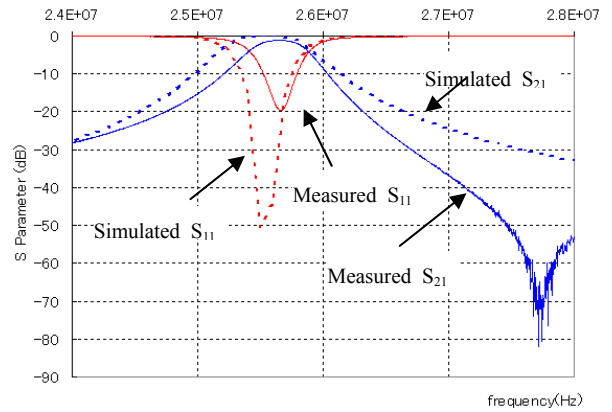

Fig. 12 Frequency characteristics of designed system

Another discrepancy of both results from the design is the shift of the center frequency from the designed value 25 MHz. It is because we did not adjust the frequency, referring to eq. (4). We have not succeeded to shift the value of parasitic capacitance of a spiral coil effectively, and hence, we left the capacitance C as it is.

Table 2 Circuit parameters for smaller coupling between spiral resonators

(a) Given parameters (b) Calculated parameters

f_r	2.50E+07 Hz	C	2.902E-12 F
R_g	50 Ω	M	1.085E-07 H
R_l	50 Ω	Q_{eg}	2.510
L	1.40E-05 H	M_g	5.025E-07 H
k	0.00775	k_g	0.1501
L_g	8.00E-07 H	L_l	8.000E-07 H
		M_l	5.025E-07 H

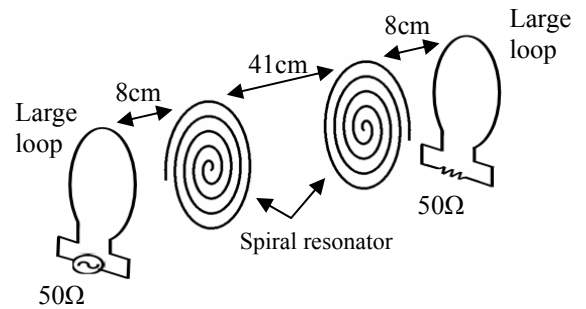

Fig. 13 Configuration for smaller coupling between spiral resonators

Table 2 and Fig. 13 show a design example for smaller coupling between spiral resonators. The simulated and measured results of constructed system are shown in Fig. 14, exhibiting a fairly good agreement with the designed value, again.

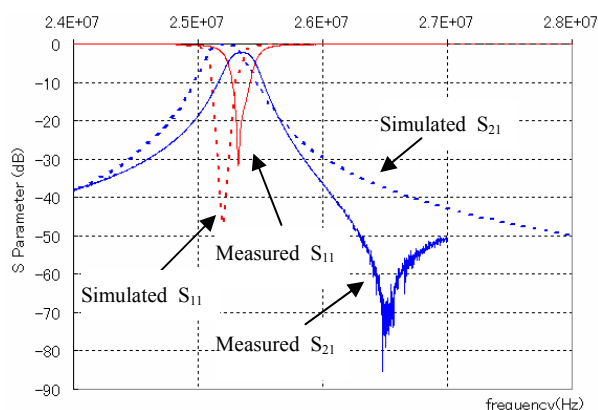

Fig. 14 Frequency characteristics for the configuration in Fig. 13 and Table 2

In spite of the deficiencies mentioned above, the simulated and measured values reasonably agree with the design. After small improvements, the theory will become more effective for resonator-coupled WPT systems.

VI. Conclusion

We have developed a design method of wireless power transfer systems based on magnetically coupled resonators, for the first time. It makes use of the filter design theory, considering the WPT system a bandpass filter. Unique modification of the filter theory has been carried out to cope with the WPT systems.

Design starts from obtaining the equivalent circuit of the WPT system. Parametric property of each circuit element obtained by EM simulation or measurement is used to realize the system, comparing it with the designed element values

Two design examples elucidate the feasibility of the proposed method. But further refinement of the method is required to attain exact agreement for the design and realized system response.

References

- [1] A. Kurs, A. Karalis, R. Moffatt, J.D. Joannopoulos, P. Fisher, M. Soljacic, “wireless power transfer via strongly coupled magnetic resonances”, *Science*, vol.317, pp.83-86, July 2007
- [2] G.Matthaei, L.Young, E.M.T.Jones, *Microwave filters, impedance-matching networks, and coupling structures*, Norwood, MA , Artech House, ,1980.
- [3]小森琢也、栗井郁雄：「共鳴型ワイヤレス給電システムの簡易設計」、平成 22 年信学総大 予稿集、BS-9-8、2010 年 3 月
- [4] 栗井郁雄：「MIT 型ワイヤレス給電システムの精密な設計法」、平成 22 年信学総大予稿集 BS-9-6、 2010 年 3 月
- [5]栗井郁雄：「磁気結合型ワイヤレス給電システムのBPF理論による設計法」、電気学会論文誌C, vol. 130, No. 12, (2010) 掲載予定