

An Overview of Emission Measurements in Time-domain

Stephan Braun

GAUSS Instruments GmbH,
Haferweg 19, Munich, Germany

Abstract—Measurements of electromagnetic interference in time-domain allow to reduce the scan time by several orders of magnitude, in comparison to automated scans performed by the tuned selective voltmeters, which are known as EMI receivers. In this paper an overview of methods and systems is shown which perform the measurement in time-domain and use the short-time fast Fourier transform for the calculation of the spectrum rather than a sequential measurement performed by EMI receivers. Baseband systems that allow to speed up tests by several order of magnitude are presented as well as FFT-based instruments that use a heterodyne RF-frontend to increase the bandwidth of the system. Today's and future requirements given by CISPR 16-1-1 are discussed. Solutions to fulfill such requirements are discussed. Comparison measurements between EMI receivers and time-domain EMI measurement system are shown.

I. INTRODUCTION

Since the 30's of the last century tuned selective voltmeters have been used to measure electromagnetic interference [1]. Later automated scans have enabled sequential measurements over a sequence of frequencies. Such instruments are today known as EMI receivers. EMI receivers are used for full compliance measurements according to CISPR 16-1-1 [2]. For pre-compliance measurements and overview measurements spectrum analyzers are used, because they allow fast sweeps. However the main drawback of both instruments is the sequential measurement at the frequencies where the measurement should be performed.

Because the information of the disturbance at all frequencies is entirely described by the signal in time-domain, research has been performed during the last 10 years on the topic how to capture the signal with sufficient dynamic range and which digital signal processing methods will yield to the same results as known from EMI receivers. The measurement of the EMI signal in time-domain and the parallel emulation of several thousand receivers by digital circuits reduce the total measurement time in comparison to a sequential scan by several orders of magnitude. The total measurement time, known also as scan time is the time that is necessary to perform a scan over a number of frequencies. At each frequency the signal is weighted by a detector e.g. quasipeak for a fixed time interval which is known as measurement time or dwell time.

The time-domain EMI measurement system consists of a floating point analog-to-digital converter based on the principle of multiresolution for digitization of the EMI signal [3]. The short-time fast Fourier transform (STFFT) and a Gaussian

window function provides a digital bank of filters which have a Gaussian shape and fulfill the requirements according to CISPR 16-1-1. Real-time digital signal processing is performed on Field Programmable Gate Arrays (FPGAs). Such FPGAs are reconfigurable circuits that are programmed to contain all the digital modules like the STFFT and the digital detector modes peak, quasipeak, average, CISPR-average and CISPR-RMS-AVG. In comparison to conventional PC they have a 20 times higher computation power. The block diagram of a multiresolution realtime time-domain EMI measurement system is shown in Fig. 1. The EMI signal is received via a

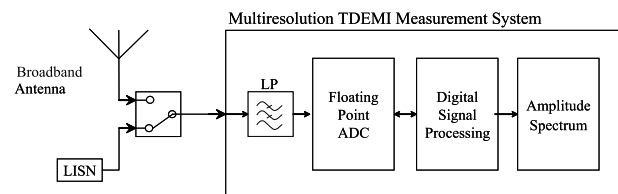

Fig. 1. Multiresolution Time-domain EMI Measurement System

broadband antenna [4]. By a multiresolution analog-to-digital Converter (ADC) system a floating point analog-to-digital conversion is performed [3]. The measured and digitized EMI signal is processed via digital signal processing and the amplitude spectrum is displayed.

In the history of the research on emission measurements in time-domain several publications exist. One of the first systems were based on a digital storage oscilloscope and used the fast Fourier transform as presented by C. Keller [5]. An algorithm that allows measurements in the peak, average and rms detector modes to be simulated has been presented in [6]. An algorithm for the quasi-peak detector mode has been presented in [7]. With both algorithms almost all requirements that are given by CISPR 16-1-1 had been fulfilled [8], except continuous processing which is mandatory to provide a gapless IF signal.

II. EMI RECEIVERS

A. Overview

EMI receivers measure the signal of electromagnetic interference in the frequency domain. The measurement for a given set of frequencies is performed sequentially. Today's EMI receiver are heterodyne or superheterodyne receivers. The

block diagram of a conventional heterodyne receiver is shown in Fig. 2. The pre-selective input filter suppresses signals that

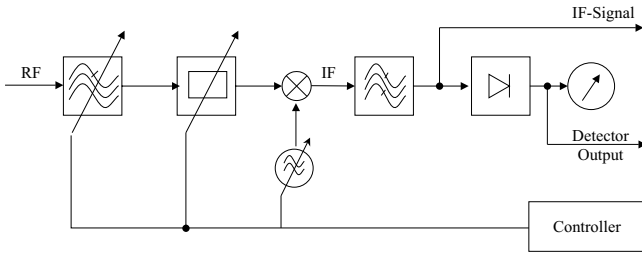

Fig. 2. Conventional Heterodyne Receiver

are outside the band of interest. By this way the dynamic range is improved. By a controllable attenuator the level of the signal is controlled in a way, that the following mixer does not overload. A mixer and a local oscillator perform a down-conversion of the signal to an intermediate frequency (IF). The signal is band-pass filtered by an IF-filter that has to fulfill CISPR 16-1-1. The output signal is weighted by a peak, average, CISPR-average, rms and quasi-peak detector mode for the selected dwell time. The IF signal s_{IF} is provided as an analog output signal.

B. IF-Signal

The analog output signal s_{IF} is described in the frequency domain by:

$$S_{IF}(f) = S(f - f_{sel} + f_{IF})H_{IF}(f) \quad (1)$$

where f_{sel} is the selected frequency. The EMI signal is shifted to the intermediate frequency f_{IF} and multiplied by the frequency response of the IF-filter. H_{IF} is the amplitude response of the IF-filter.

III. TIME-DOMAIN EMI MEASUREMENT SYSTEM

A. Fast Fourier Transform

Digital spectral calculation is performed via the discrete Fourier transform (DFT). Algorithms for DFT computations that exploit symmetry and repetition properties of the DFT are defined as FFT. The DFT formulation considers periodic repetition of the signal in time-domain and is given as follows:

$$X[k] = \sum_{n=0}^{N-1} x[n]e^{-j2\pi kn/N} \quad (2)$$

B. Short-Time Fast Fourier Transform

EMI signals consist of stationary and transient signals as well as noise. In order to model the exact behavior of an EMI receiver the STFFT is used. By the use of a gaussian window function the IF-Filter is modeled according to its impulse bandwidth, noise-bandwidth and the filter masks as defined in CISPR 16-1-1. By the STFFT a spectrogram is calculated. This spectrogram shows a discretization in frequency and time. The resolution in frequency is described by the bin-width Δf . The resolution in time is described by a time step T_{sBB} . The

inverse of the time-step is called baseband sampling frequency f_{sbb} . The mathematical formulation of the STFFT is given:

$$Z[m, k] = \sum_{n=0}^{N-1} x[n]w[n - m]e^{-\frac{j2\pi kn}{N}} \quad (3)$$

As $w[n]$ is symmetric there are several possibilities to reformat (3) and perform the calculation of the spectrogram. Typically (3) is reformatted in a way that the signal x is shifted and the window function w has an index that is independent on m . In the time-domain EMI measurement system $w[n]$ is a Gaussian window function that models the IF-filter of an EMI receiver [7].

The relation between the samples that are processed by a single FFT and the number of samples where shifting is performed is described by the overlap factor O_f . The number of FFT calculations N_O that have to be performed for N samples is described by:

$$N_O = \frac{1}{1 - O_f} = \frac{f_{sbb}}{\Delta f} \quad (4)$$

The discretization in the time-domain has to be high enough to fulfill the Nyquist criterion. The requirements according to the overlapping have been discussed in [9].

C. Comparison to EMI Receiver

It is known from several publications that a STFFT with a window function is equivalent to a bank of filters with down converter and down sampler [10],[11]. STFFT has been even derived from a bank of filters [12].

The block diagram of such a system is shown in Fig. 3. The

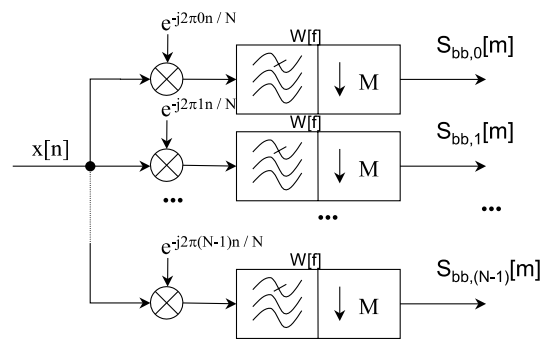

Fig. 3. Bank of Filters

ratio of the downsampler M is given by:

$$M = f_s / f_{sbb} \quad (5)$$

$W[f]$ is the discretized transfer function of the modeled IF-Filter.

In conclusion the STFFT performs a baseband down conversion at N frequencies, while the EMI receiver performs a conversion to an IF. The IF signal is demodulated. As only the magnitude is taken into account both systems will yield to the same result.

An alternative approach which has been presented for APD measuring is shown in [13]. It uses a parallel digital implementation of digital down converters on FPGAs. Such systems are also digital direct baseband receivers. The measurement result is obtained at several frequencies simultaneously.

IV. REALTIME OPERATION

An overview of the digital signal processing blocks is presented in Fig. 4. In order to perform measurements in the

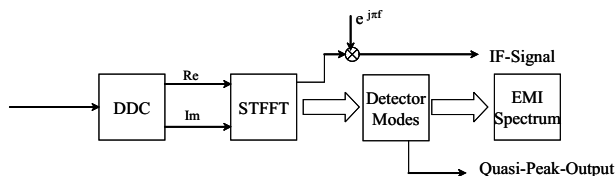

Fig. 4. Realtime Digital Signal Processing

frequency range 9 kHz - 1 GHz, the sampling rate f_S has to be at least 2 GS/s to fulfill the Nyquist criteria. Because of the limited clock speed of the hardware used the input of the digital down-conversion (DDC) is subdivided into 8 parallel inputs with at least 250 MS/s per channel. As a consequence the maximum frequency has to be reduced by a factor of 8. Thus the frequency range $0 - f_S/2$ is subdivided into 8 bands. Each band has a bandwidth of at least 125 MHz. The spectrum of each band is processed separately by DDC, STFFT and the digital detectors. During a full scan, all 8 bands are measured sequentially.

A. Short-Time Fast Fourier Transform

In Fig. 5 the block diagram of a STFFT implementation with 4 parallel FFT calculating units is shown. The overlapping is achieved by three cascaded shift registers.

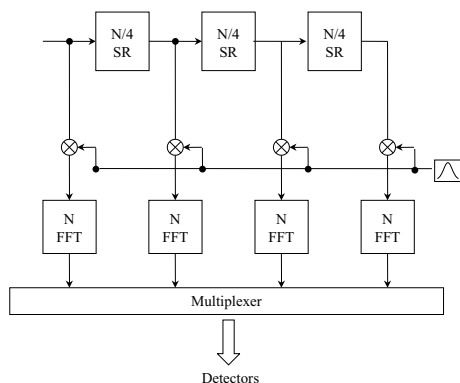

Fig. 5. Short-time Fast Fourier Transform

B. Measurements above the Nyquist Frequency

As the sampling frequency of ADCs is about one order of magnitude lower than the maximum frequencies of available RF-mixers, a combination of an ultra-broadband analog down converter and a time-domain EMI measurement can be used to extend the frequency range. As there are today ADCs that

cover band A,B and C/D, these measurements can be carried out by a multiresolution analog-to-digital converter systems. As above 1 GHz the requirements are also different according to CISPR 16-1-1 ultra broadband down conversion is used.

V. INTERNATIONAL EMC STANDARDS

A. The CISPR Standards

For the instrumentation in the frequency range 9 kHz - 18 GHz the requirements are defined in CISPR 16-1-1. The measurement setup and procedures for conducted emission measurements are shown in CISPR 16-2-1. For the measurement of disturbance power the CISPR 16-2-2 is the standard to be applied. The procedure for radiated emission measurements are shown in CISPR 16-2-3.

The standard CISPR 16-1-1 is today describing a black box which has to show a specific indication or output for a specific input signal. FFT-based measuring instruments can be validated according to CISPR 16-1-1 however the instrument must provide the possibility to show the result at only one frequency and provide an IF output.

The standards CISPR 16-2-1, CISPR 16-2-2 and CISPR 16-2-3 provide a description for the measurement with systems that can perform a sequential measurement over several frequencies. However time-domain EMI measurement systems can get the result at several thousand frequencies with a single measurement. Such a possibility is today not mentioned.

B. The IEC JTF FFT

The IEC JTF FFT has discussed the topic of validation of FFT-based measuring instruments, as well as measurement errors that may occur due to a certain implementation. As in the past there had been systems which performed a data reduction in the time-domain, it is proposed to put in the maintenance cycle report (MCR) the requirement for FFT-based measuring instruments that they must perform a gapless processing during the dwell time. Further it is proposed to remove the IF output as a mandatory requirement to a requirement which has to be present when disturbance analysis shall be performed.

For the MCR of the standards CISPR 16-2-1, CISPR 16-2-2 and CISPR 16-2-3 it is proposed to give a guide for the new scan times of such systems and to give the user the information that it could be now possible to get the measurement result in a single scan without the necessity of prescan, data reduction and final scan.

C. Test Time

By time-domain EMI measurement systems the test time can be decreased by about one order of magnitude. For conducted emission measurements the time-domain EMI measurement system provides a reduction of the scan time by a factor of 4000. Thus conducted emission measurements can be simplified, and speed up. A single scan in the quasipeak takes about 12 s. Thus a scan per each LISN phase with the detector mode and dwell time required by the applicable

product standard can be performed. Afterwards the evaluation can be performed automatically.

For measurements of the disturbance power, the measurement is performed at several positions of the power cord. Afterwards the measurement results are maximized.

Radiated emission measurements using a time-domain EMI measurement system can be sped up during pre- and final scans. For measurements in an full anechoic room full maximization method [14] provides the highest reliability and fast test results. Because of the short test time for tests performed with the time-domain EMI measurement system the reliability of test results can be also increased by longer dwell times.

VI. MEASUREMENTS

An emission measurement has been performed in the frequency range 30 MHz - 1 GHz of a PC. The dwell time has been 100 ms. The measurement in the time-domain took 11 s. In the frequency domain the measurement took about 50 minutes. The result is shown in Fig. 6. It is shown that the

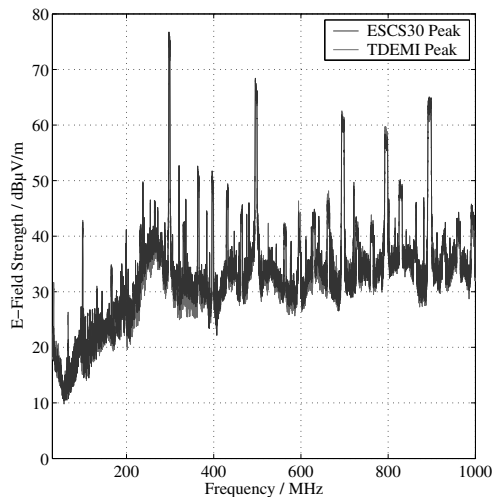

Fig. 6. Emission of a Desktop Computer, Peak Detector

maximum deviations are about 1 dB.

A complete angular characterization of the emission of a PC with a closed case has been performed. The result is shown in Fig. 7. This characterization within several minutes.

VII. CONCLUSION

An overview of emission measurements in time-domain has been given. It has been shown that such systems can be used in the future for compliance measurements. The JTF FFT has generated committee drafts to explicitly mention the FFT-based instruments in the CISPR standards and to update also the sections about the application of such instruments. Measurement results show a good agreement between traditionally EMI receiver. The typical deviations are similar to deviations between EMI receivers models.

VIII. ACKNOWLEDGMENT

The author would like to thank the Bayerische Forschungstiftung for support.

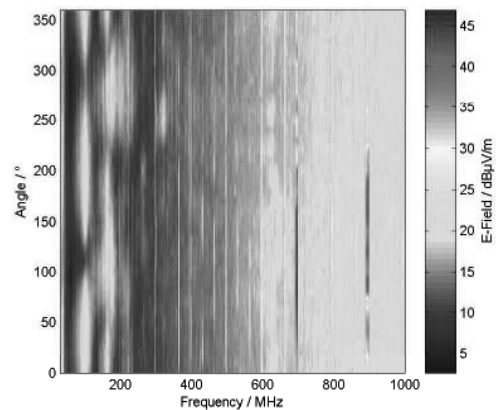

Fig. 7. Angular Characterization of a PC

REFERENCES

- [1] C. R. Barhydt, "Radio noise meter and its application," in *General Electric Rev. Vol. 36*, pp. 201–205, 1933.
- [2] CISPR16-1-1, *Specification for radio disturbance and immunity measuring apparatus and methods Part 1-1: Radio disturbance and immunity measuring apparatus – Measuring apparatus*. International Electrotechnical Commission, 2003.
- [3] S. Braun and P. Russer, "A Low-Noise Multiresolution High-Dynamic Ultra-Broad-Band Time-Domain EMI Measurement System," *IEEE Transactions on Microwave Theory and Techniques*, vol. 53, pp. 3354–3363, Nov 2005.
- [4] Rohde&Schwarz, *Ultra Broadband Antenna HL562 ULTRALOG*. Data sheet, 2001.
- [5] C. Keller and K. Feser, "Fast Emission Measurement In Time Domain," in *14th International Zurich Symposium On Electromagnetic Compatibility, Zurich, Switzerland, 20.–22.2.2001*, pp. –, no. 70K7, 2001.
- [6] F. Krug, T. Hermann, and P. Russer, "Signal Processing Strategies with the TDEMI Measurement System," in *2003 IEEE Instrumentation and Measurement Technology Conference Proceeding, May 20–22, Vail, USA*, pp. 832–837, 2003.
- [7] S. Braun, F. Krug, and P. Russer, "A novel automatic digital quasi-peak detector for a time domain measurement system," in *2004 IEEE International Symposium On Electromagnetic Compatibility Digest, August 9–14, Santa Clara, USA*, vol. 3, pp. 919–924, Aug. 2004.
- [8] S. Braun, M. Aidam, and P. Russer, "Development of a multiresolution time-domain emi measurement system that fulfils cispr 16-1," in *2005 IEEE International Symposium On Electromagnetic Compatibility, Chicago, USA*, pp. 388–393, 2005.
- [9] S. Braun, A. Frech, and P. Russer, "CISPR Specification and Measurement Uncertainty of the Time-domain EMI Measurement System," in *2008 IEEE International Symposium On Electromagnetic Compatibility, Detroit, USA*, pp. 1–4, August 2008.
- [10] A. V. Oppenheim and R. W. Schaffer, *Discrete-Time Signal Processing*. ISBN 0-13-214107-8, Prentice-Hall, 1999.
- [11] F. J. Harris, "On the Use of Windows for Harmonic Analysis with the Discrete Fourier Transform," in *Proceeding of the IEEE*, vol. 66, no. 1, pp. 51–83, 1978.
- [12] J. Allen and L. Rabiner, "A unified approach to short-time Fourier analysis and synthesis," in *Proceedings of the IEEE*, vol. 65, pp. 1558–1564, 1977.
- [13] K. Gotoh, Y. Matsumoto, S. Ishigami, T. Shinozuka, and M. Uchino, "Development and evaluation of a prototype multichannel apd measuring receiver," in *2007 IEEE International Symposium On Electromagnetic Compatibility, Honolulu, USA*, pp. 1–6, jul 2007.
- [14] S. Braun and P. Russer, "Uncertainty analysis and novel test procedures performed with a realtime time-domain emi measurement system," in *2007 IEEE International Symposium On Electromagnetic Compatibility, Honolulu, USA*, pp. 1–4, jul 2007.