

Making Light Work of the Future IP Network

HPSR 2002, Kobe Japan, May 28, 2002

Ken-ichi Sato
NTT Network Innovation Laboratories

© Copyright 2002, NTT Network Innovation Laboratories



Progress in Optical Fiber Transmission in Japan

Transmission capacity increase has been significant since the introduction of optical fiber transmission. Commercial systems have been introduced five or six years after the experimental results were presented.

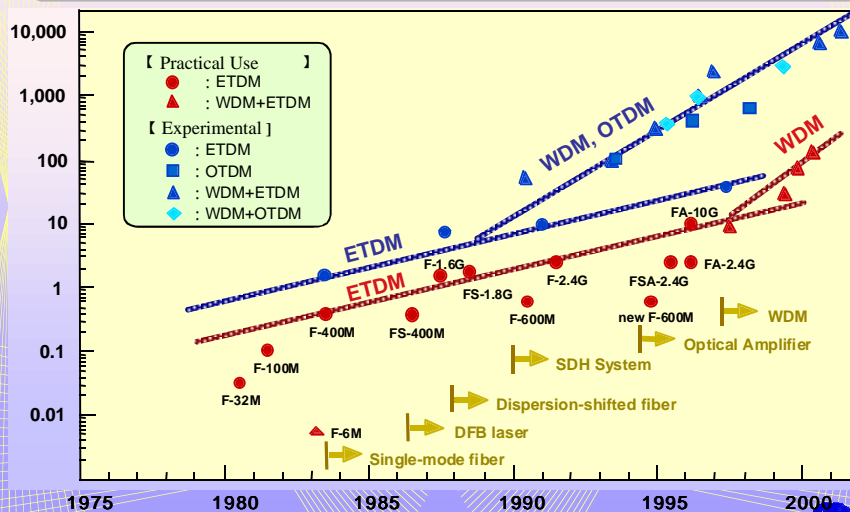

© Copyright 2002, NTT Network Innovation Laboratories



43Gbit/s OTN Line Terminal Developed by NTT

- High-speed Si LSI Technology
- OTN Standard
- New Modulation Format



OS, OR, CS-RZ

OTU3 Frame Generation/Termination

Direct Mapping of GbEther / STM-16



Control and Administration

**1Tbit/s (43Gbit/s x 25)
Transmission was
Successfully Achieved in
NTT's Field Environment
with the Prototype System**

© Copyright 2002, NTT Network Innovation Laboratories

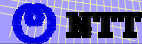

Evolution of Photonic Network

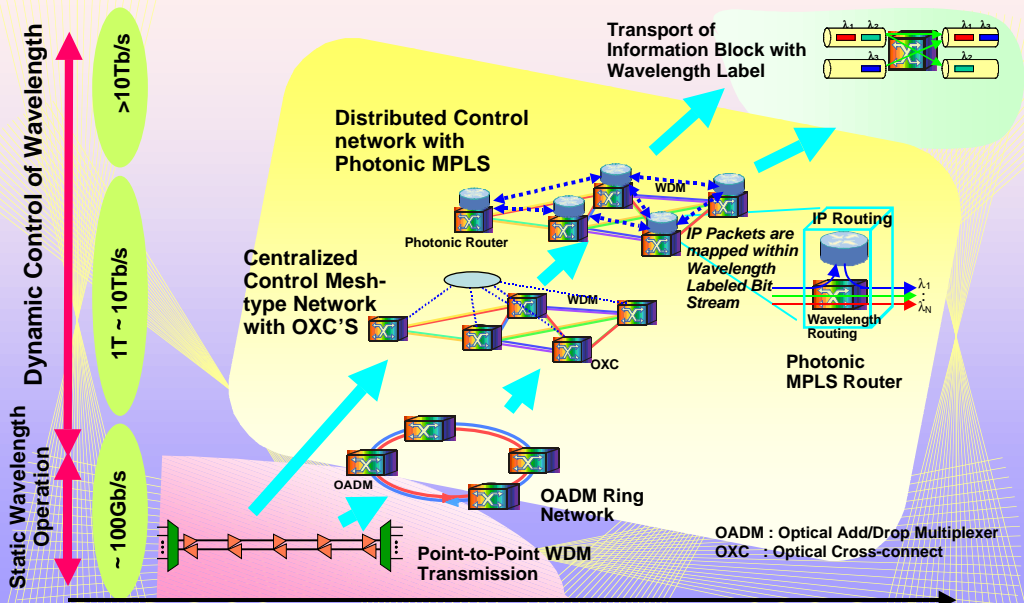

© Copyright 2002, NTT Network Innovation Laboratories



Wavelength Routing on Photonic Superhighway

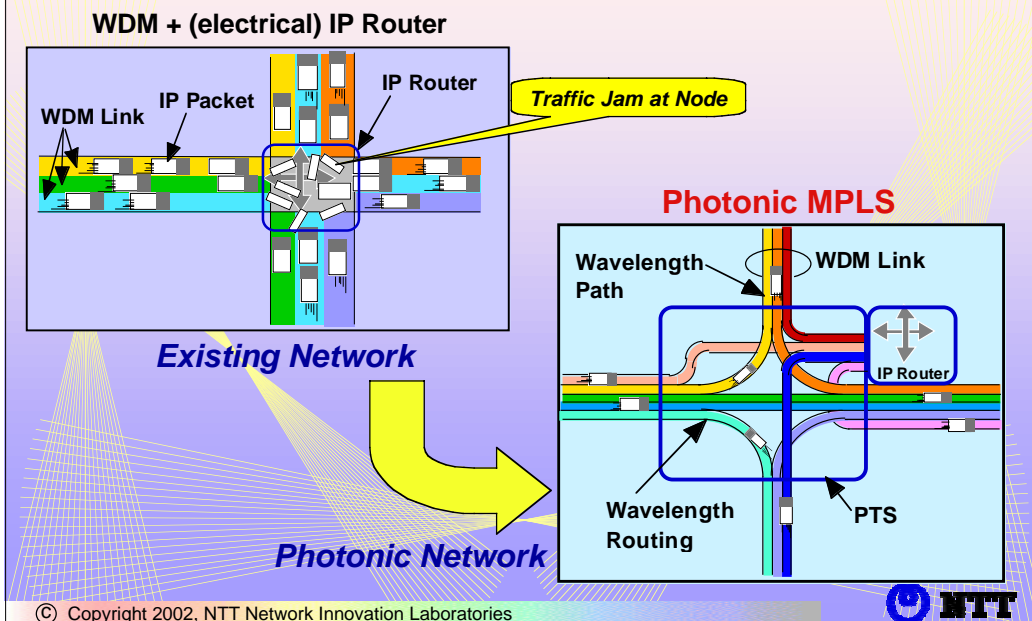

Internet Hop Distance Distribution

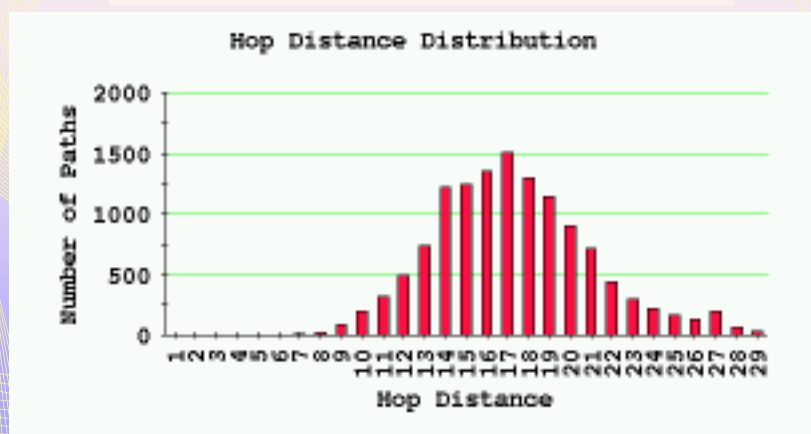

<http://www.caida.org/outreach/presentations/nanog9806/>

© Copyright 2002, NTT Network Innovation Laboratories

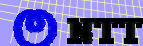

MPLS and Photonic MPLS

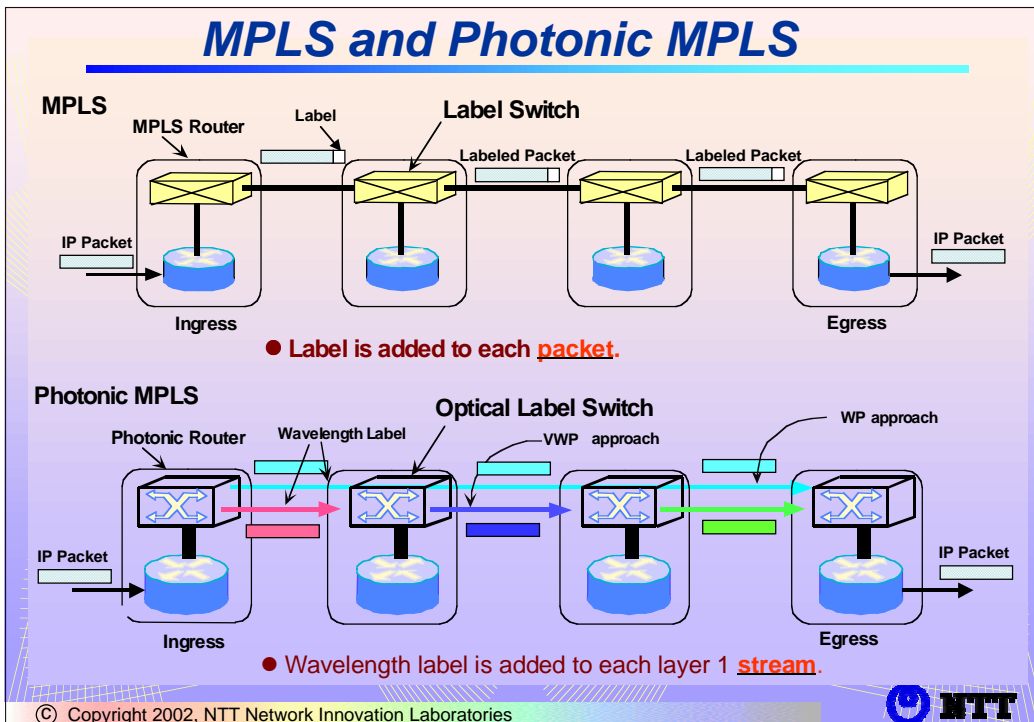

OXC's and Photonic MPLS routers co-exist?

Yes, each has its own application.

Photonic MPLS routers are regarded as the ultimate in integrated router systems.

OXC's create optical platform on which different transfer mode services can be provided.

Criteria of the Selection

- Services (IP only or IP and other services, ex. Lambda service?)
- Ownership (Are IP routers and OXC's and Transmission Equipment owned by the same provider?)
- Segmentation of Network Management

End-to-End Node Cost Reduction

• IP over WDM

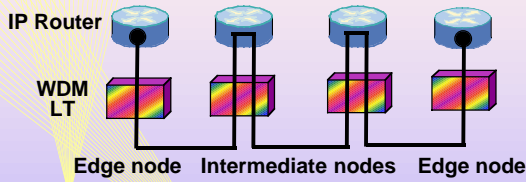

- 2.5 Gbit/s IP router I/F (OC-48c or STM-16)
- 20 Gbit/s transmission ($2.5 \text{ Gbit/s} \times 8 \lambda$)

• IP over Photonic

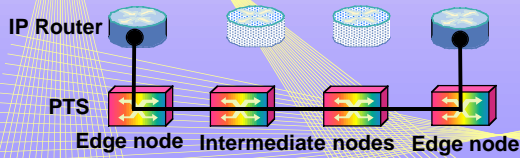

End-to-End node cost ratio "IP over photonic" to "IP over WDM"

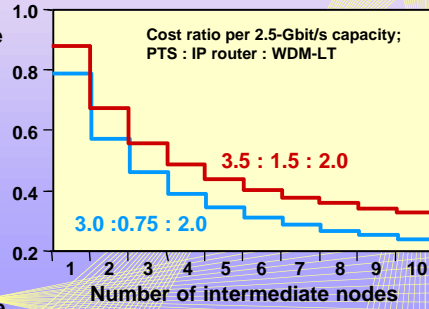

© Copyright 2002, NTT Network Innovation Laboratories

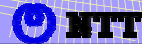

Photonic MPLS Router Presented at SUPERCOMM' 2001



© Copyright 2002, NTT Network Innovation Laboratories



Outlook of Photonic MPLS Router



© Copyright 2002, NTT Network Innovation Laboratories

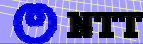

Photonic MPLS Router Specifications

<i>Item</i>	<i>Specifications</i>
Throughput	More than 5Gpps (Obtained with wavelength routing and MPLS router)
System throughput	Maximum 2.56 Tbit/s
UNI	POS, ATM, GEther, etc.
Optical switch architecture	Delivery and coupling type
Optical switch	Planar Lightwave Circuit (PLC) thermo-optical switch
Operating wavelength range	1550 nm band (C-band)
Optical channel speed	2.5 Gbit/s (up gradable to 10 Gbit/s)
Number of wavelengths	32 per fiber
Number of fiber ports	8 input /output pairs (fiber port can be added one by one)
Total switch scale	256 x 256 channels
Scalability	The number of available optical channels is expandable up to 256, with 8 wavelengths' modularity (each switch module accommodates 8 wavelengths.)
MPLS router scalability	Maximum number of available POS interface is 128. Consists of one to twenty MPLS routers.

© Copyright 2002, NTT Network Innovation Laboratories



Optical Cross-Connect Architecture

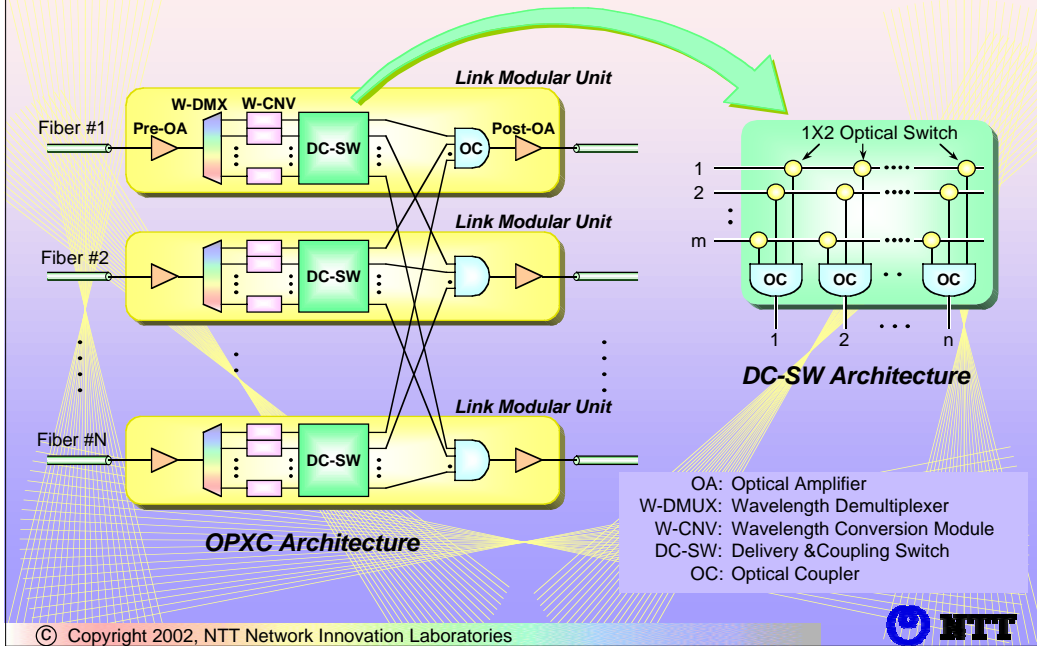

DC-SW Package



© Copyright 2002, NTT Network Innovation Laboratories



Different Switch Architecture

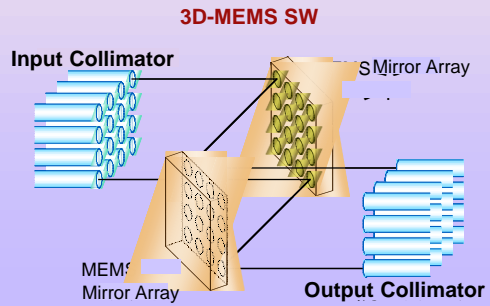
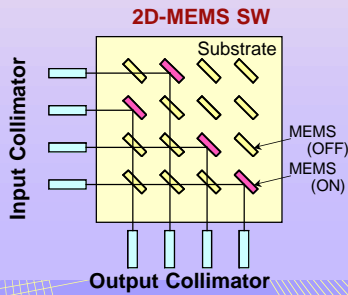
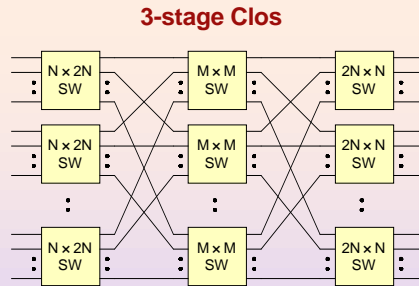
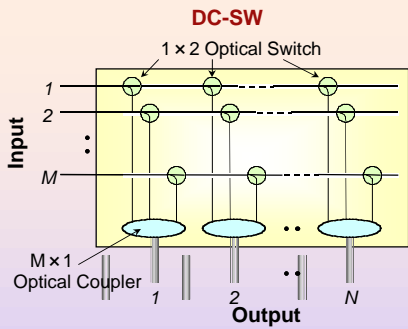

© Copyright 2002, NTT Network Innovation Laboratories



Necessary Hardware vs. Switch Architecture

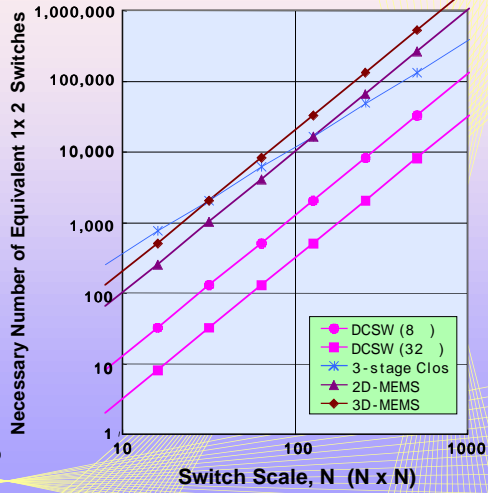
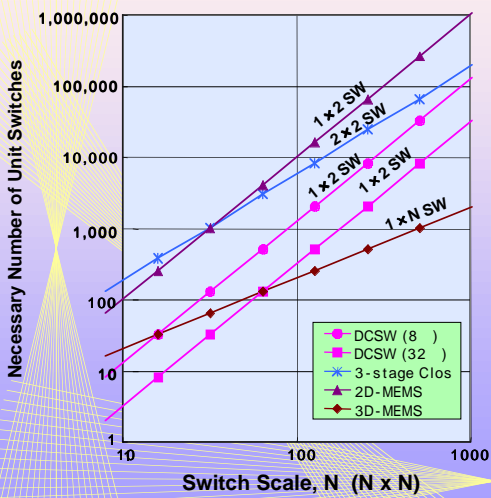

© Copyright 2002, NTT Network Innovation Laboratories



Switch Reliability

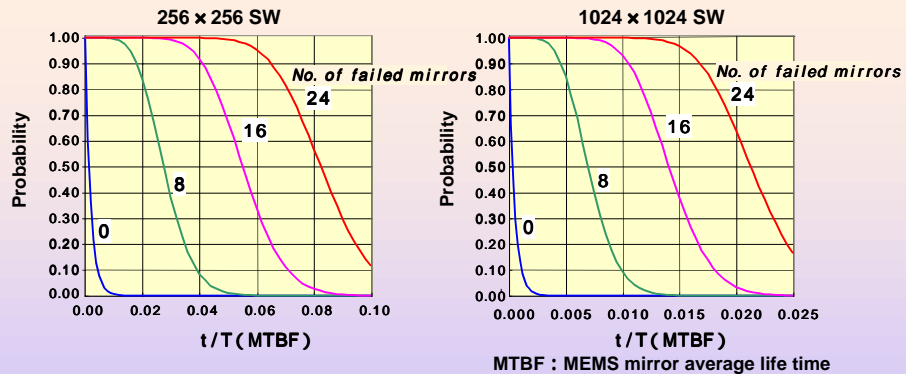

If the system life time is specified as 10 % failure of all mirrors, then about 50 % of systems show a life time of just 1.8 years when the MTBF of each mirror including the feedback control system is 20 years.

Very reliable 3-D MEMS mirror and control system are required.

(PLC TO-SW is shown to be very reliable; MTBF of 8x8 switch is estimated to be longer than 100 years.)

© Copyright 2002, NTT Network Innovation Laboratories

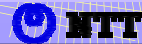

Available Cell Buffer per Link in ATM Systems

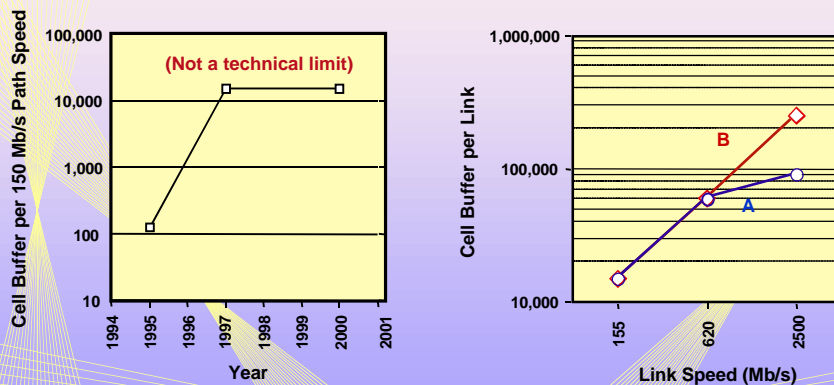

© Copyright 2002, NTT Network Innovation Laboratories



Volume of Memory

Semiconductor Memory (S-RAM)

40 k cell/chip

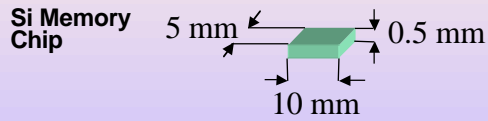

$$v = 6 \times 10^{-4} \text{ mm}^3/\text{cell}$$

Optical Fiber Delay Line

1 cell @ 10 Gb/s

Bare fiber
Straight Line

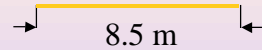

$$V = 100 \text{ mm}^3/\text{cell} > 10^5 v$$

Bare fiber
Coiled

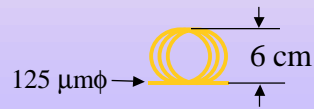

$$V = 16000 \text{ mm}^3/\text{cell} > 10^7 v$$

© Copyright 2002, NTT Network Innovation Laboratories

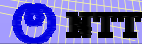

Cutting-edge Optical Technologies

© Copyright 2002, NTT Network Innovation Laboratories



Cost-Effective Large Capacity Transmission

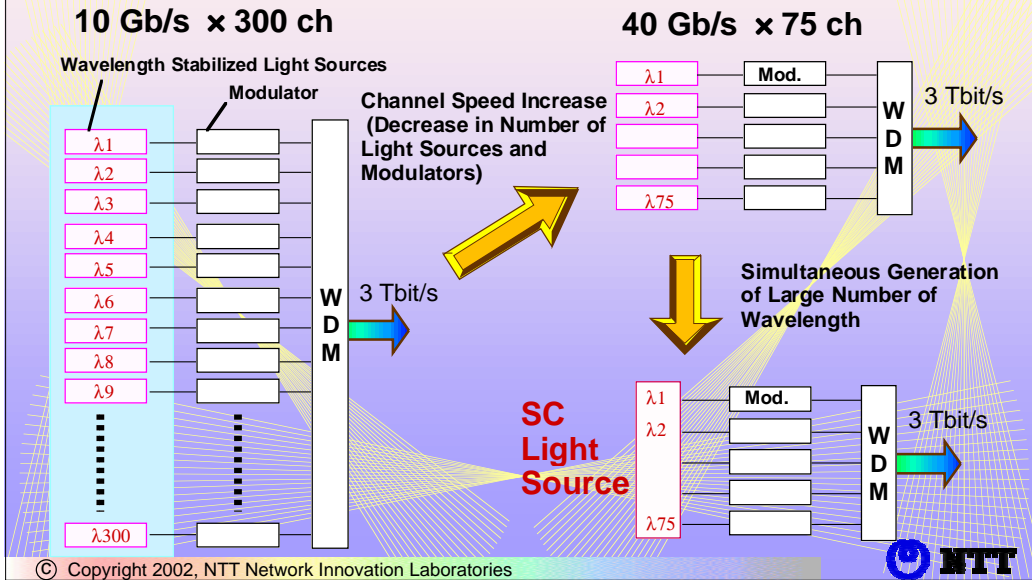

Multi-wavelength Pulse Generation with SC Optical Source

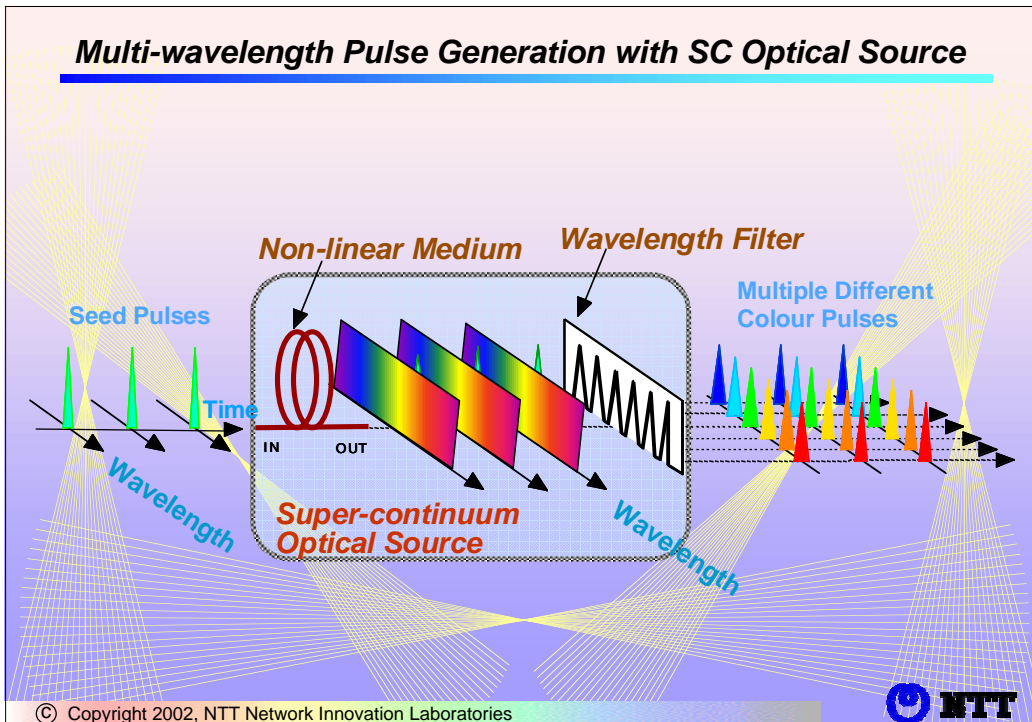

Over1000 Channel High-quality Optical Carrier Generation

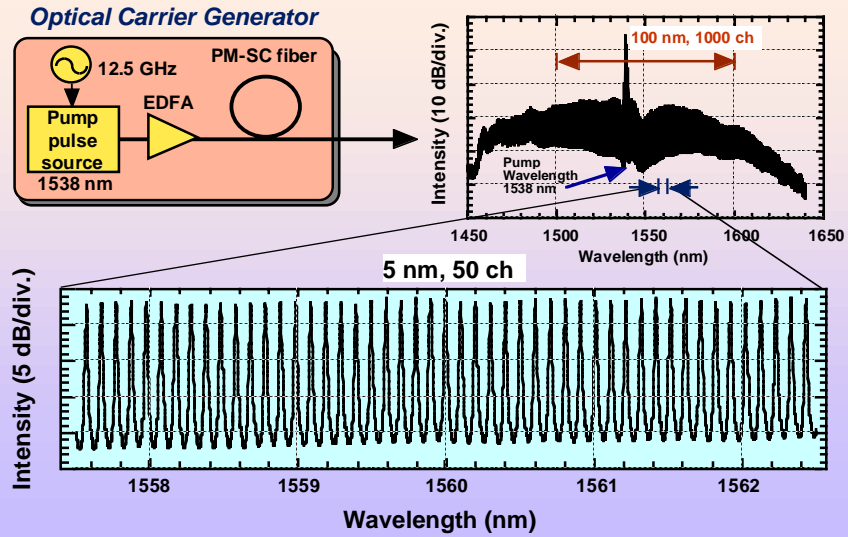

H. Takara, et.al, ECOC' 2000 Post deadline paper PD-3.1, September, 2000, Munich.

© Copyright 2002, NTT Network Innovation Laboratories



SNR and Q Factor of Generated Optical Carriers

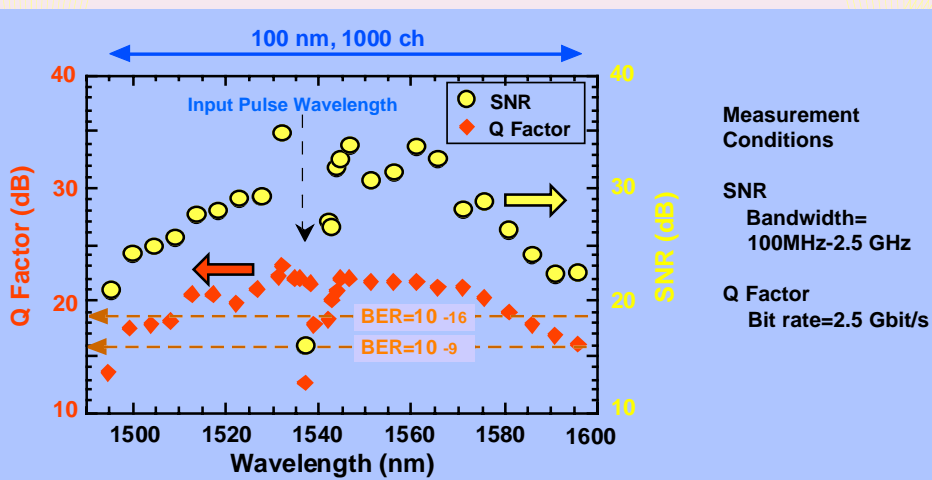

© Copyright 2002, NTT Network Innovation Laboratories



SC Light Source Exhibited at OFC'2002



Features

- 25-GHz spacing optical frequency grid (accuracy of within less than one ppm)
- Covers S, C and L frequency bands
- Polarization-maintaining fiber output
- Internal/external grid frequency oscillator
- Dimension: W43 x H13 x D48 (in cm)

© Copyright 2002, NTT Network Innovation Laboratories

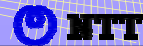

Ultra-Wideband WDM Transmission

Gain Bands of Fiber Amplifiers

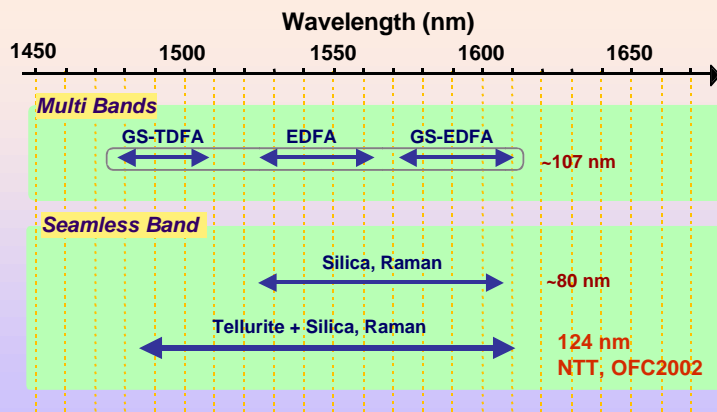

- Seamless transmission
 - Eliminating gaps between bands
 - No excess loss of WDM DEMUX/MUX

K. Takara, et.al, ECOC' 2002 Post deadline paper, 2002, Anaheim.

© Copyright 2002, NTT Network Innovation Laboratories

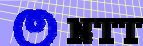

BER after 160 km transmission

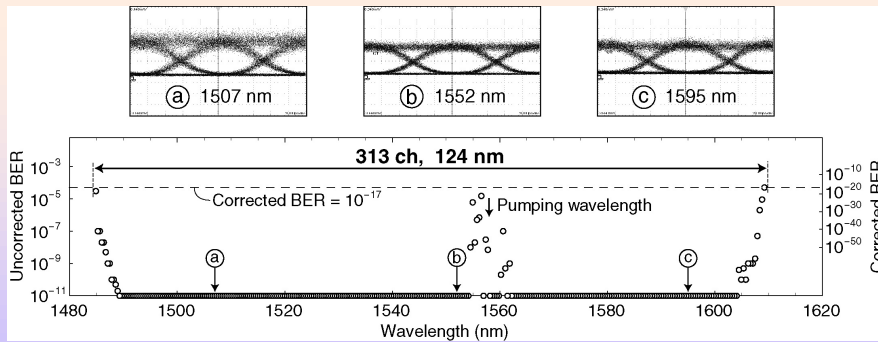

without FEC 291 ch (120 nm) BER < 10^{-9}

with FEC 313 ch (124 nm) BER < 10^{-17}

K. Takara, et.al, ECOC' 2002 Post deadline paper, 2002, Anaheim.

© Copyright 2002, NTT Network Innovation Laboratories



1010ch – 10GHz AWG with Tandem Configuration

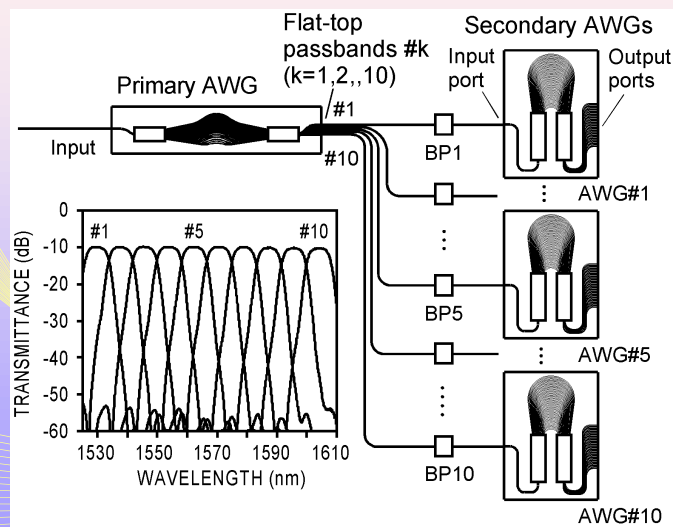

K. Takada, et.al, ECOC' 2000 Post deadline paper PD-3.8, September, 2000, Munich.

© Copyright 2002, NTT Network Innovation Laboratories



Demultiplexing Properties of 1010ch – 10GHz AWG

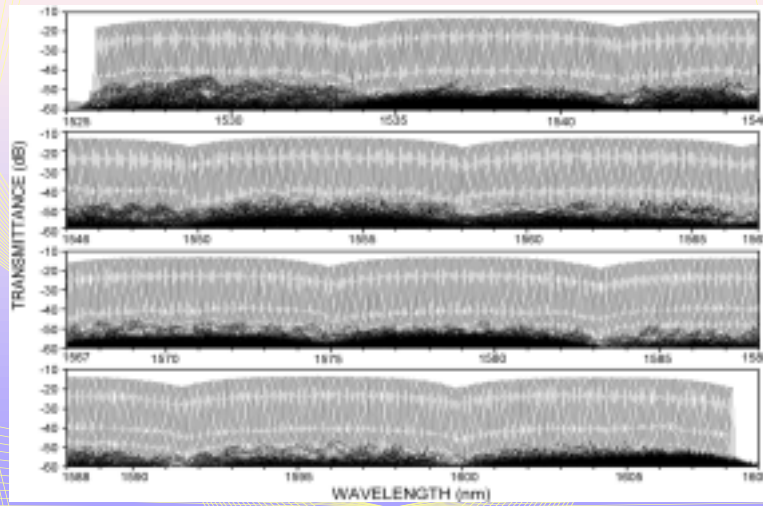

K. Takada, et al, ECOC' 2000 Post deadline paper PD-3.8, September, 2000, Munich.

© Copyright 2002, NTT Network Innovation Laboratories



Photonic Crystal Structure Fiber

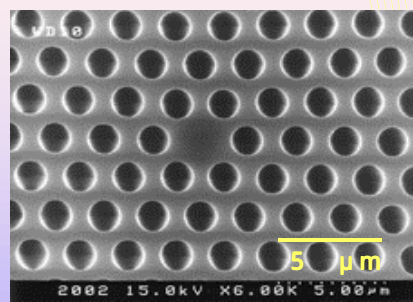
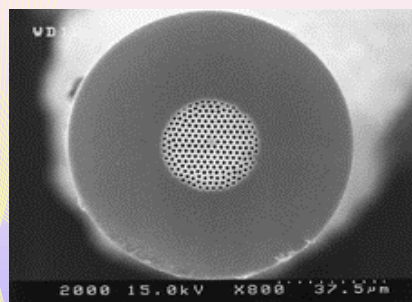

Optical Loss=3.2dB/km @ 1.55μm
Zero Dispersion Wavelength=0.81μm

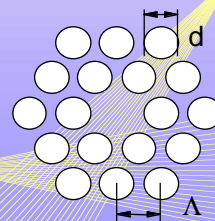

Kubota et al (NTT), CLEO 01 PD, CPD3

© Copyright 2002, NTT Network Innovation Laboratories

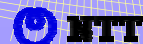

Characteristics of Photonic Crystal Fibers

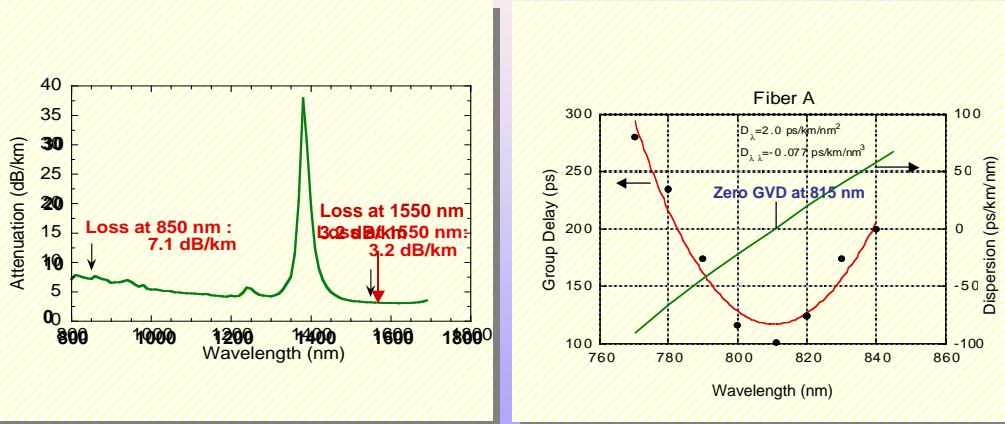

Kubota et al, CLEO 01 PD, CPD3

© Copyright 2002, NTT Network Innovation Laboratories



Photonic Crystal Structure Fiber

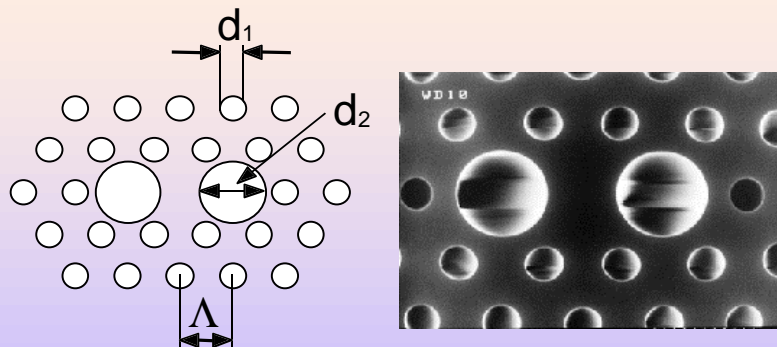

$$d_1/d_2=0.4 \text{ (when 1, no birefringence)}$$

© Copyright 2002, NTT Network Innovation Laboratories



Characteristics of Polarization-Maintaining Photonic Crystal Fiber

- comparison to PANDA Fiber -

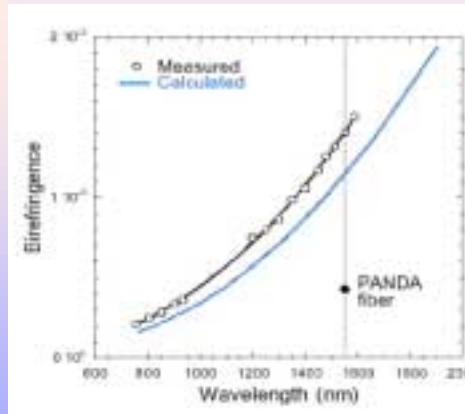

Birefringence can be larger than PANDA fiber by proper design of cross section, such as core diameter and d_1/d_2 . (see left figure)

Loss can be comparable to PANDA fiber. (currently, 1.3 dB/km at 1.55 μm)

Low Cost PM-PCF is made of single material, pure silica. Without drilling or filling with another material.

© Copyright 2002, NTT Network Innovation Laboratories

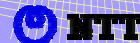

Conclusion

- Traffic engineering capability is the key to developing large scale and robust telecommunications networks.
- Introducing optical paths enhances network performance in transmission and routing, and also provides a means of traffic engineering.
- Photonic MPLS router offers all the necessary attributes in an integrated fashion and is indispensable to create large scale IP core networks. Development of an effective MPLS control protocol (GMPLS) and hardware optimization in terms of cost-performance are very important issues.
- OXCs and photonic MPLS routers using distributed or centralized control mechanisms have different applications: The optimization of the system and control system in terms of the application (an overlay approach or Photonic MPLS; Dedicated design for IP) needs to be done before we can reap the maximum benefits.

© Copyright 2002, NTT Network Innovation Laboratories

